

Алматы (7273)495-231  
 Ангарск (3955)60-70-56  
 Архангельск (8182)63-90-72  
 Астрахань (8512)99-46-04  
 Барнаул (3852)73-04-60  
 Белгород (4722)40-23-64  
 Благовещенск (4162)22-76-07  
 Брянск (4832)59-03-52  
 Владивосток (423)249-28-31  
 Владикавказ (8672)28-90-48  
 Владимир (4922)49-43-18  
 Волгоград (844)278-03-48  
 Вологда (8172)26-41-59  
 Воронеж (473)204-51-73  
 Екатеринбург (343)384-55-89

Иваново (4932)77-34-06  
 Ижевск (3412)26-03-58  
 Иркутск (395)279-98-46  
 Казань (843)206-01-48  
 Калининград (4012)72-03-81  
 Калуга (4842)92-23-67  
 Кемерово (3842)65-04-62  
 Киров (8332)68-02-04  
 Коломна (4966)23-41-49  
 Кострома (4942)77-07-48  
 Краснодар (861)203-40-90  
 Красноярск (391)204-63-61  
 Курск (4712)77-13-04  
 Курган (3522)50-90-47  
 Липецк (4742)52-20-81

Магнитогорск (3519)55-03-13  
 Москва (495)268-04-70  
 Мурманск (8152)59-64-93  
 Набережные Челны (8552)20-53-41  
 Нижний Новгород (831)429-08-12  
 Новокузнецк (3843)20-46-81  
 Ноябрьск (3496)41-32-12  
 Новосибирск (383)227-86-73  
 Омск (3812)21-46-40  
 Орел (4862)44-53-42  
 Оренбург (3532)37-68-04  
 Пенза (8412)22-31-16  
 Петрозаводск (8142)55-98-37  
 Псков (8112)59-10-37  
 Пермь (342)205-81-47

Ростов-на-Дону (863)308-18-15  
 Рязань (4912)46-61-64  
 Самара (846)206-03-16  
 Санкт-Петербург (812)309-46-40  
 Саратов (845)249-38-78  
 Севастополь (8692)22-31-93  
 Саранск (8342)22-96-24  
 Симферополь (3652)67-13-56  
 Смоленск (4812)29-41-54  
 Сочи (862)225-72-31  
 Ставрополь (8652)20-65-13  
 Сургут (3462)77-98-35  
 Сыктывкар (8212)25-95-17  
 Тамбов (4752)50-40-97  
 Тверь (4822)63-31-35

Тольятти (8482)63-91-07  
 Томск (3822)98-41-53  
 Тула (4872)33-79-87  
 Тюмень (3452)66-21-18  
 Ульяновск (8422)24-23-59  
 Улан-Удэ (3012)59-97-51  
 Уфа (347)229-48-12  
 Хабаровск (4212)92-98-04  
 Чебоксары (8352)28-53-07  
 Челябинск (351)202-03-61  
 Череповец (8202)49-02-64  
 Чита (3022)38-34-83  
 Якутск (4112)23-90-97  
 Ярославль (4852)69-52-93

Россия +7(495)268-04-70

Казахстан +7(7172)727-132

Киргизия +996(312)96-26-47

<https://vickers.nt-rt.ru> || [vsh@nt-rt.ru](mailto:vsh@nt-rt.ru)

**EATON**

**Vickers**

**Proportional Valves**

Proportional solenoid valves for pressure and flow control



# Electro-Proportional Valves

## Section Contents

<b>Model</b>	<b>Typical Application Pressure bar (psi)</b>	<b>Rated Flow L/min (USgpm)</b>	<b>Page</b>
Proportional Valve Cartridges – Introduction, Features and Benefits.....			B-3
<b>Proportional Flow Controls, Poppet Type</b>			
EPV10 .....	350 (5000) .....	30 (8) .....	B-4
EPV16 .....	280 (4000) .....	160 (42) .....	B-8
<b>Proportional Flow Controls, Spool Type</b>			
EFV1-12-0 .....	210 (3000) (NEW) .....	104 (27.5) .....	B-14
EFV1-12-C .....	210 (3000) (NEW) .....	70 (18.6) .....	B-17
<b>Proportional Relief</b>			
ERV1-10 spool type .....	210 (3000) .....	60 (15) .....	B-20
ERV1-16 spool type .....	210 (3000) .....	132 (35) .....	B-22
ERV2-10 spool type .....	210 (3000) .....	2,8 (0.75) .....	B-24
<b>Proportional Pressure Reducing/Relieving</b>			
EPRV2-8 .....	35 (500) .....	7,6 (2) .....	B-26
EPRV1-10 .....	35 (500) .....	7,6 (2) .....	B-28
EPRV1-16 .....	35 (500) .....	38 (10) .....	B-30

### Note

Proportional valve solenoid coils and electronic valve drivers are covered in section C of this Catalog.

# Electro-Proportional Valves

## Section Introduction

This section gives basic specifications for the complete line of Vicker's screw-in proportional control valves. Its purpose is to provide a quick, convenient reference tool when choosing proportional valves or when designing a system using these components.

The **EPV10** has several outstanding performance features which give it a unique position in the screw-in cartridge valve market. Valve gain linearity, flow force pressure compensation characteristics above 20 bar (300 psi) and low internal leakage.

The **EPV16** is a proportionally controlled two-way poppet type valve. The main poppet amplifies a small flow through the pilot circuit and is comparable to a transistor. As the transistor uses small currents to control larger currents, the hydraulic valve transistor or VALVISTOR uses the pilotflow to control the main stage flow with servo-like response flow to control.

The **EFV1** is a proportionally controlled two-way, spool type flow control valve. Technically the valve is not pressure compensated, but at high differential pressures it is partially flow force pressure compensated. For fully pressure compensated flow control applications with the EFV1 valve it is necessary to employ a compensation element such as a DPS2 or PCS valve as described in section K.

The **ERV1-10** is an electric, proportionally controlled, internally pilot operated, spool type screw-in relief valve. It is capable of handling flows from 3,8-60,0

L/min (1-15 USgpm) at pressures from 35-210 bar (500-3000 psi). Also available is an ERV1-16 which is capable of handling flows from 7,6-132 L/min. (2-35 USgpm) at pressures from 35-210 bar (100-500 psi).

The **ERV2-10** is a low flow electric proportionally controlled relief valve similar to the ERV1-10. This valve is rated for flows from 0,2-2,8 L/min (0.05-0.75 USgpm) and pressures up to 35 bar (500 psi).

The **EPRV1-10** is an electric, proportionally controlled, internally pilot operated, spool type, screw-in pressure reducing/relieving valve. It is capable of handling flows from 0-76 L/min (0-20 USgpm) at set pressures from 14-35 bar (200-500 psi). Also available is an ERV1-16 which is capable of handling flows from 0-38 L/min (0-10 USgpm) at set pressures from 14-35 bar (200-500 psi).

Vickers proportional pressure and flow control valves are designed to be easily controlled by the simplest of DC electrical devices such as a 12 volt battery and a potentiometer.

Varying the voltage at the coil is one of the simplest means of control available. Any of the Vickers DC coils will work on most of these valves simply by varying the voltage between 0 and 75% of the rated coil voltage. It should be noted that as the operating temperature of a coil increases, the solenoid force decreases. Therefore if the voltage is held constant as the coil heats up then valve pressure (or flow) will change.

### Electrical current controls with PWM are recommended for all Eaton proportional valves.

Closed-loop electrical control with feedback from the parameter to be monitored will provide the most accurate control.

### Valve Features and Benefits

- Products in this catalog have been fatigue tested to one million cycles at 132% or 10 million cycles at 115% of rated pressure
- All operating parts are hardened steel, ground and honed for long life and low leakage
- Designed for maximum flexibility and minimal space requirements
- All exposed cartridge surfaces are zinc dichromate plated to resist corrosion
- Reliable, economical and compact
- Rated flows up to 160 L/min (42 USgpm)
- Optional nose-in, side-out or side-in, nose out flow direction (EPV16 series)

### Coil Features and Benefits

The valves in this catalog are offered with a choice of two or three standard voltages and several types of electrical connections. For other coil ratings and connections, consult your Eaton applications engineer.

- Variety of voltages and terminations
- Coils are interchangeable for serviceability on the EPV10 and EPV16. Coils are interchangeable for

serviceability on the ERV1-10, EPV1-16, EPRV1-10 and EPRV1-16

- Compact, one-piece weather-proof encapsulated design. Eliminates need for extra seals
- An arc suppression diode molded into the coil is available as a standard option on ERV, EPRV and EFV valves

### Fluid Cleanliness

Proper fluid condition is essential for long and satisfactory life of hydraulic components and systems. Hydraulic fluid must have the correct balance of cleanliness, materials, and additives for protection against wear of components, elevated viscosity, and inclusion of air.



#### WARNING

Application of these products beyond published performance specifications may cause valve malfunction which may result in personal injury and/or damage to the machine.



#### WARNING

For pressures over 210 bar (3000 psi) use steel housing.

# EPV10

Proportional flow control valve (poppet type)

## Description

The EPV10 is a direct acting, uni-directional, poppet type, 2-way, 2-position, normally closed proportional flow control valve.

## Operation

In the de-energized position, flow is blocked from port 2 to port 1, with no reverse flow permitted. When energized, flow is

allowed from port 2 to port 1 in direct proportion to the current applied to the solenoid coil.

## Functional Symbol

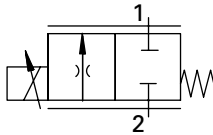

## Sectional View

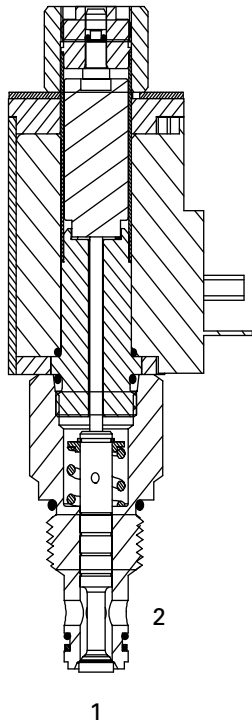

## RATINGS AND SPECIFICATIONS

*Performance data is typical with fluid at 21,8 cSt (105 SUS) and 49°C (120°F)*

Typical application pressure (at port 2)	350 bar (5000 psi)
Cartridge fatigue pressure (infinite life)	350 bar (5000 psi)
Rated flow	0 - 30 L/min (0 - 8 USgpm)
Operating ambient temperature	-30° to 90°C (-22° to 194°F)
Cavity	C-10-2
Fluids	Anti-wear hydraulic oils with Buna-N seals (standard) Phosphate esters (non-alkyl) with Viton® seals are available by request <small>Viton is a registered trademark of E.I. DuPont</small>
Weight cartridge only	0,78 kg (1.72 lbs)
Filtration	70 - 210 bar (1000 - 3000 psi) Cleanliness code 17/15/12 210+ bar (3000+ psi) Cleanliness code 15/13/11
Standard housing materials	Aluminum or Steel
Typical hysteresis	Less than 4% of rated current at 10 bar pressure drop – Pulse Width Modulated (PWM)
Internal leakage	3 cm <sup>3</sup> maximum @ 140 bar (2000 psi) and oil viscosity of 30 cSt
Oil viscosity range	10 - 800 cSt
Nominal supply voltage	12 or 24 VDC
Threshold current	Adj. from 400 - 800 mamp (12 VDC) Adj. from 200 - 400 mamp (24 VDC) Adj. from 600 - 1400 mamp (12 VDC) Adj. from 300 - 700 mamp (24 VDC)
Coil current @ max flow	0.7 amps max @ 24 VDC 1.4 amps max @ 12 VDC
Recommended PWM frequency	100 - 200 Hz application dependent, 100 Hz typ
Coil resistance @ 20°C (86°F)	12V-6.5Ω 24V-25.0Ω
Power consumption @ rated current and 20°C coil temperature	12V-12.8 watts 24V-12.8 watts
Cartridge seal kit	02-317580 (Buna-N)

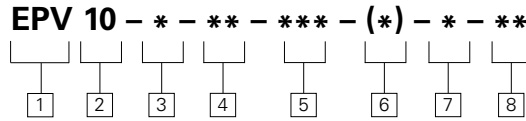

**1 Function**

**EPV** - Electro-proportional flow control valve, poppet type

**2 Size**

**10** - 10 Size

**3 Valve housing material**

Omit for cartridge only

**A** - Aluminum

**S** - Steel

Maximum operating pressure for aluminum housing is 210 bar (3000 psi).



Aluminum housings can be used for pressures up to 210 bar (3000

psi). Steel housings **must** be used for operating pressures **above** 210 bar (3000 psi).

**Dimensions**

mm (inch)

Valve is shown with "U" coil. See Section C for coil information. Torque cartridge in housing

**A** - 47-54 Nm (35-40 ft. lbs)

**S** - 68-75 Nm (50-55 ft. lbs)

**4 Port size**

CODE	PORT SIZE	HOUSING NUMBER	
		Aluminum	Steel
<b>3G</b>	3/8" BSPP	876703	02-175103
<b>6H</b>	SAE 6	876700	—
<b>8H</b>	SAE 8	876701	—
<b>6T</b>	SAE 6	—	02-175100
<b>8T</b>	SAE 8	—	02-175101

See section J for housings.

**7 Coil/Connector types**

CONNECTOR	COIL PART NUMBER	
	12VDC	24VDC
<b>Blank</b> - No coil		
<b>W</b> - Leadwire (DC only)	02-154072	02-154073
<b>Q</b> - Spade terminals (DC only)	02-317154	02-317155
<b>U</b> - DIN 43650	02-154070	02-154071
<b>Y</b> - Metri-Pack 150 male*	02-308808	02-308809
<b>F</b> - Weather-Pack male	02-308810	02-308811

\*Preferred Packard connector.

**5 Voltage rating**

**12D** -12VDC  
**24D** - 24VDC

**6 Manual override option\***

**Blank** - No manual override

**M** - Pin type

**S** - Screw type

\*Manual override is available in two different configurations, either push pin type is used when system pressure does not exceed 210 bar (3000 psi). The screw type can be used at any system pressure. For details see page B-9.

**8 Design number**

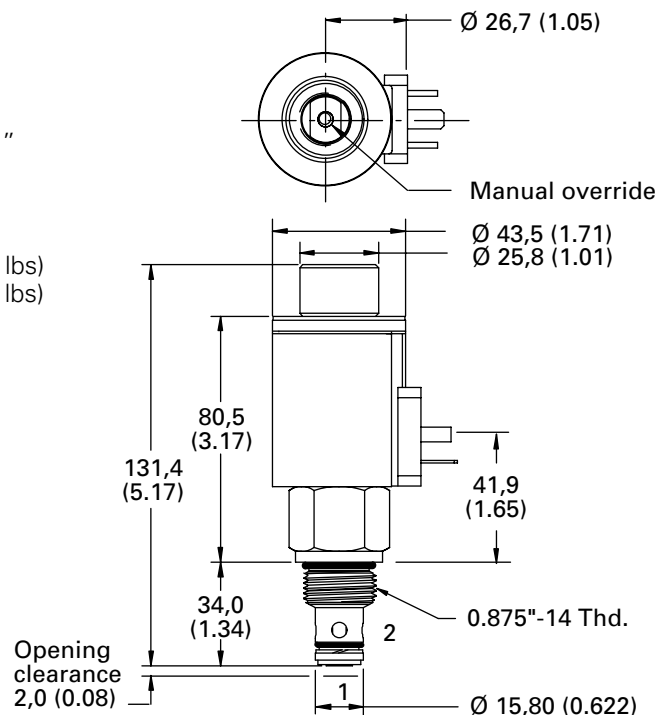

**WARNING**

The cavity should be machined to the 14,29 (0.562) maximum diameter and 36,00 (1.417) maximum depth. (See cavity, page M-12)



**WARNING**

When using the "Screw Type" override, care must be taken to return the override back to its neutral position before activating the valve. Failure to take this precaution may result in personal injury or damage to the machine.

# Performance Curves

EPV10

## Step Response Data

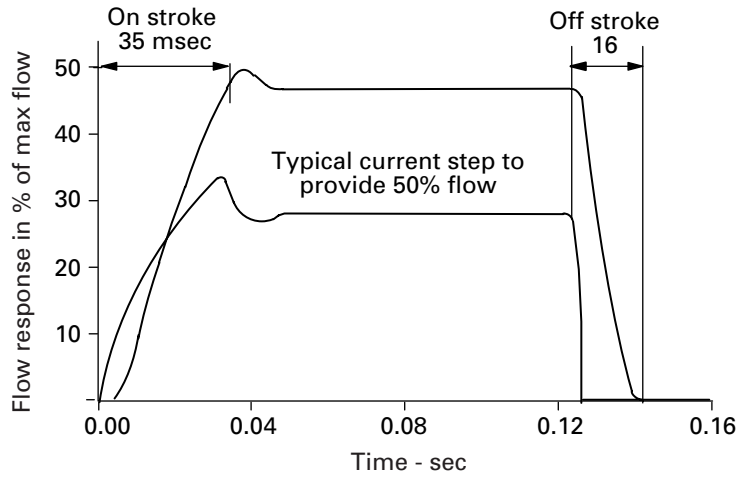

## Flow vs Current

With 10 bar differential between inlet and outlet

**A** - 210 bar (3000 psi) pressure drop from Port 2 to Port 1

**B** - 10 bar (150 psi) pressure drop from Port 2 to Port 1

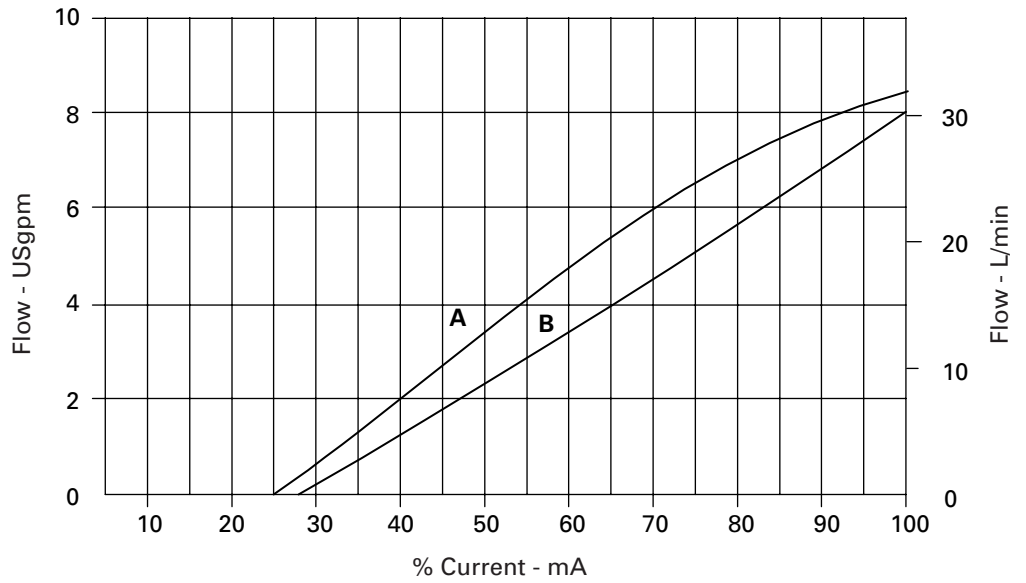

# Performance Curves

EPV10

**B**

## Flow vs Pressure Drop

Per % of Input Current

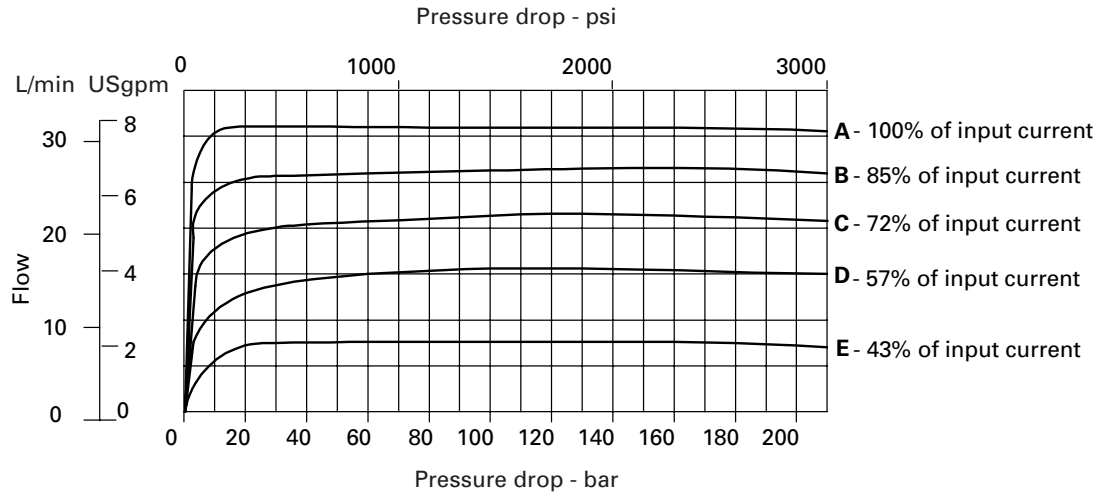

## Typical Flow Response

For an amplitude of  $\pm 40\%$  maximum stroke (center to offset) about the 50% position.

$\Delta P = 10$  bar (145 psi)

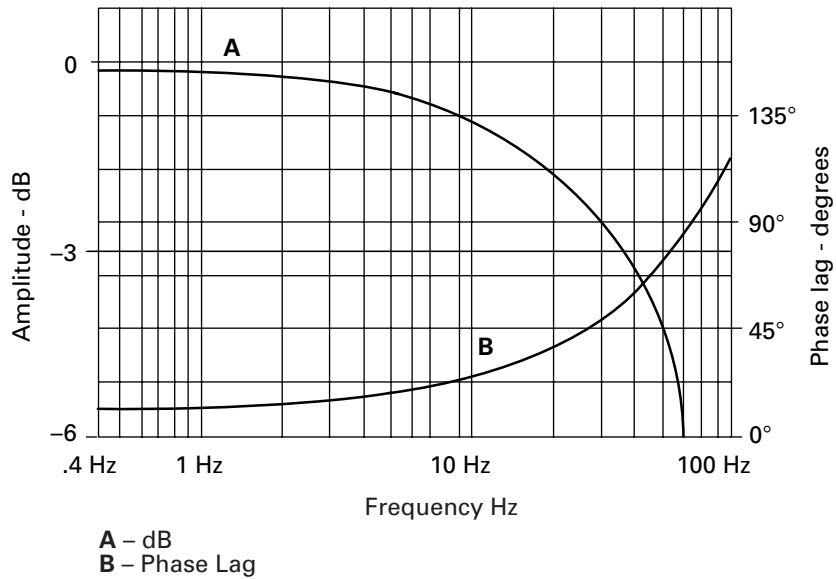

# EPV16 Valvistor®

Proportional flow  
control valve

## Functional Symbols

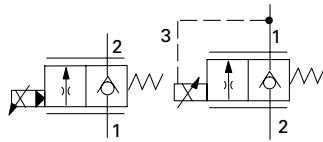

EPV16-A

EPV16-B

## Sectional View

EPV16-A Side-out, nose-in

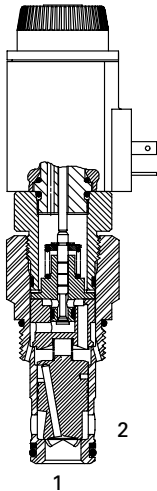

EPV16-B Side-in, nose-out

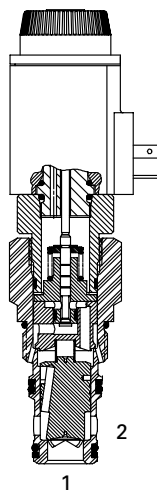

## Description

The EPV16 is a 2-way, normally closed, pressure compensated, poppet type, screw-in cartridge electro-proportional flow control valve.

## Operation

“A” style (nose in, side out)  
- In the de-energized position this valve remains closed from port 1 to port 2. When current is applied to the coil, a controlled increasing flow will be allowed from port 1 to port 2, in proportion to the current applied.

“B” style (side in, nose out)  
- in the de-energized position the valve remains closed from port 2 to port 1. When current is applied to the coil, a controlled increasing flow will be allowed from port 2 to port 1. In both examples free reverse flow is allowed in the opposite direction.

## RATINGS AND SPECIFICATIONS

*Performance data is typical with fluid at 21,8 cSt (105 SUS) and 49°C (120°F)*

Typical application pressure	280 bar (4000 psi)
Cartridge fatigue pressure (infinite life)	280 bar (4000 psi) NFA rated
Rated flow	0 to 160 L/min (42 USgpm)
Operating media temperature	-30° to 90°C (-22° to 194°F)
Cavity	C-16-3S (undercut)
Fluids	Antiwear hydraulic oils with Buna-N seals (standard) Phosphate esters (non-alkyl) with Viton® seals are available by request <small>Viton is a registered trademark of E.I. DuPont</small>
Weight cartridge only	1 kg (2.2 lbs)
Filtration	70 - 210 bar (1000 - 3000 psi) Cleanliness code 17/15/12 210+ bar (3000+ psi) Cleanliness code 15/13/11
Standard housing materials	Aluminum or steel
Typical hysteresis	Less than 4% of rated current @ 10 bar pressure drop – Pulse Width Modulated (PWM)
Internal leakage @ 140 bar (2000 psi) and oil viscosity 30cSt	EPV16A 50 cm <sup>3</sup> /min maximum EPV16B 10 cm <sup>3</sup> /min maximum
Oil viscosity range	10 - 800 cSt
Nominal supply voltage	12 or 24 VDC
Threshold current	Adj. from 400 - 800 mamp (12 VDC) Adj. from 200 - 400 mamp (24 VDC) Adj. from 600 - 1400 mamp (12 VDC) Adj. from 300 - 700 mamp (24 VDC)
Coil current for maximum flow	0.7 amps @ 24 VDC 1.4 amps @ 12 VDC
Recommended PWM frequency	65 - 150 Hz application dependent, 100 Hz typ
Coil resistance @ 20°C (68°F)	12V-6.5Ω/24V-25.0Ω
Power consumption @ rated current and 20°C coil temperature	12V-12.8 watts 24V-12.8 watts
Cartridge seal kit	02-154069 (Buna-N)



**EPV 16 - \* - \*\* - \* - \*\*\* - \*\*\* - \* - \* - \*\***

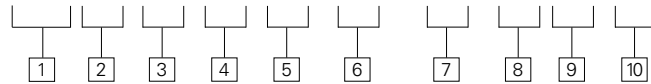

**1 Function**  
**EPV** - Electro-proportional flow control valve, poppet type

**2 Size**  
**16** - 16 Size

**3 Flow direction**  
**A** - Nose-in, side-out  
**B** - Side-in, nose-out

**4 Rated flow @ 10 bar ΔP**  
**04** - 40 L/min (10.5 USgpm)  
**06** - 60 L/min (16 USgpm)  
**10** - 100 L/min (26 USgpm)  
**16** - 160 L/min (42 USgpm)

**5 Valve housing material**  
 Omit for cartridge only  
**A** - Aluminum  
**S** - Steel

 Aluminum housings can be used for pressures up to 210 bar (3000 psi). Steel housings **must** be used for operating pressures **above** 210 bar (3000 psi).

**M** - Pin type manual override option

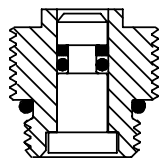

**6 Port Size**  
**0** - Cartridge only

CODE	PORT SIZE	HOUSING NUMBER			
		Aluminum EPV16-A	EPV16-B	Steel EPV16-A	EPV16-B
<b>4G</b>	1/2" BSPP	02-185448	02-166607	02-180050	02-165500
<b>6G</b>	3/4" BSPP	02-185449	02-161582	02-180051	02-164931
<b>10H</b>	SAE 10	02-185446	02-170238	—	—
<b>12H</b>	SAE 12	02-185447	02-166609	—	—
<b>10T</b>	SAE 10	—	—	02-180048	02-161983
<b>12T</b>	SAE 12	—	—	02-180049	02-161982
<b>5C</b>	CETOP5 (NFPA D05) Interface (Requires steel body)				

See section J for housings.

**7 Voltage rating**  
**12D** - 12VDC  
**24D** - 24VDC

**8 Manual override option**  
**Blank** - No manual override  
**M** - Pin type  
**S** - Screw type

\*Manual override is available in two different configurations, either push pin type is used when system pressure does not exceed 210 bar (3000 psi). The screw type can be used at any system pressure.

**S** - Screw type manual override option

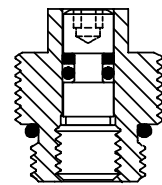

**9 Coil/Connector types**

CONNECTOR	COIL PART NUMBER	
	12VDC	24VDC
<b>Blank</b> - No coil		
<b>W</b> - Leadwire (DC only)	02-154072	02-154073
<b>Q</b> - Spade terminals (DC only)	02-317154	02-317155
<b>U</b> - DIN 43650	02-154070	02-154071
<b>Y</b> - Metri-Pack 150 male*	02-308808	02-308809
<b>F</b> - Weather-Pack male	02-308810	02-308811

\*Preferred Packard connector. See Section C for coil information.

**10 Design number**



**WARNING**

When using the "Screw Type" override, care must be taken to return the override back to its neutral position before activating the valve. Failure to take this precaution may result in personal injury or damage to the machine.



**CAUTION**

A separate check valve is required down stream to isolate the EPV valve from load forces when the EPV is used to hold a load.

# Dimensions

EPV16-A

## EPV16-A

Nose-in, side-out  
mm (inch)

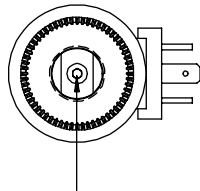

Screw type actuator (shown)  
3 mm hex socket

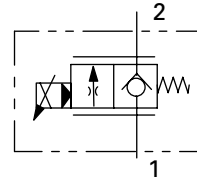

### Note

When stand alone housings are used, the following guidelines apply:

- EPV16-A: Port 3 is to be plugged.
- EPV16-B: Port 3 is to be connected to port 1 in order to provide the required feedback flow path.

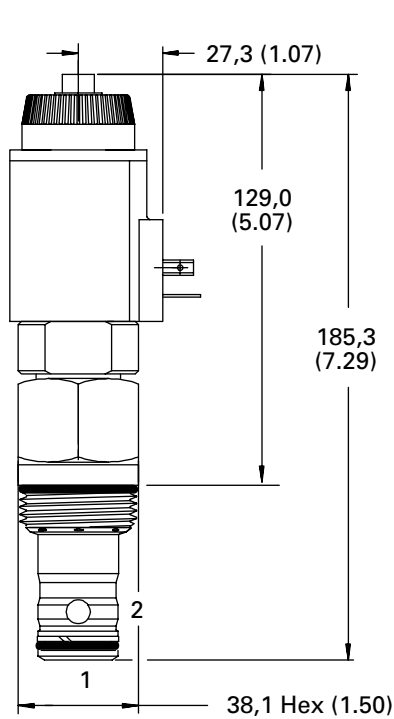

With manual actuator

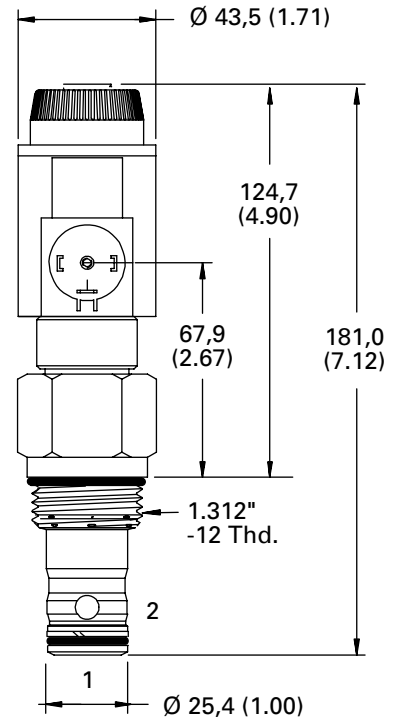

No manual actuator

Valves are shown with "U" coil. See Section C for coil information.

Torque cartridge in aluminum housing 108-122 Nm (80-90 ft. lbs)

Torque cartridge in steel housing 136-149 Nm (100-110 ft. lbs)

# Dimensions

EPV16-B

**B**

## EPV16-B

Side-in, nose-out  
mm (inch)

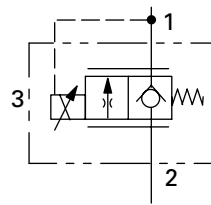
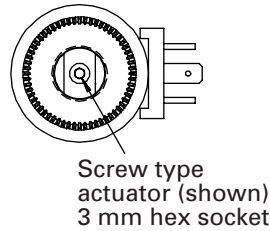

Required external connection with standard C-16-3S cavity

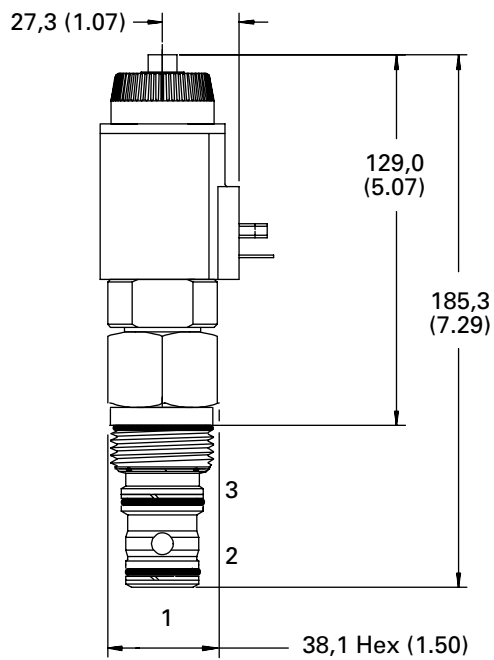

With manual actuator

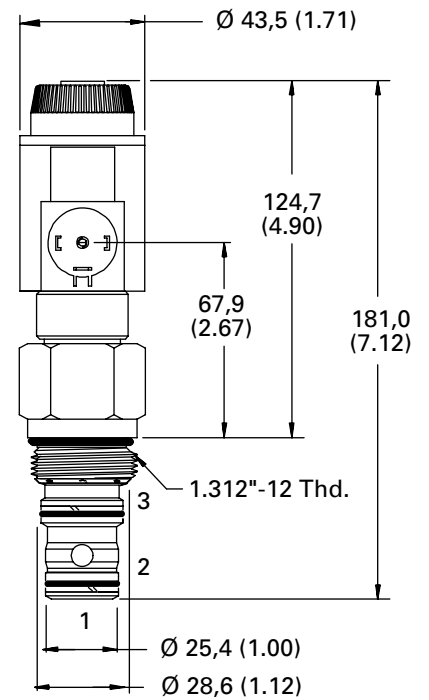

No manual actuator

For EPV16-B (flow 2 to 1), Port 3 must be connected to Port 1 externally to the cartridge, either by passages in the cavity block or external plumbing. When purchased with undercut body, this connection is included in the body and Port 3 is not machined. A separate external port connection is not required for EPV16-A (flow 1 to 2).

# Dimensions

EPV16

## EPV16-A-\*\*\*-S-5C-\*\*-D-(\*)--12 CETOP 5 Interface

mm (inch)

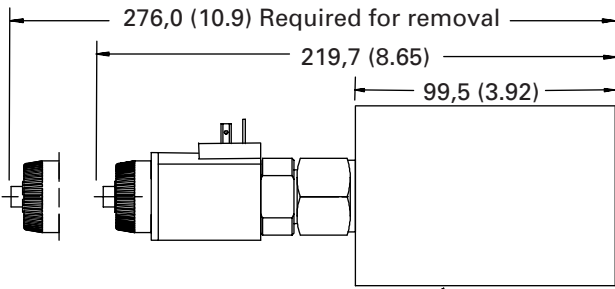

ISO-4401-AC-05-4-A (NFPA D05)  
mounting surface

.250-20 UNC x 2.500"  
socket head cap screw  
(Bolt Kit 255634)  
M6 x 60 socket head cap  
screw (Bolt Kit 689623)

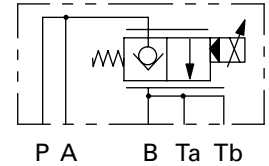
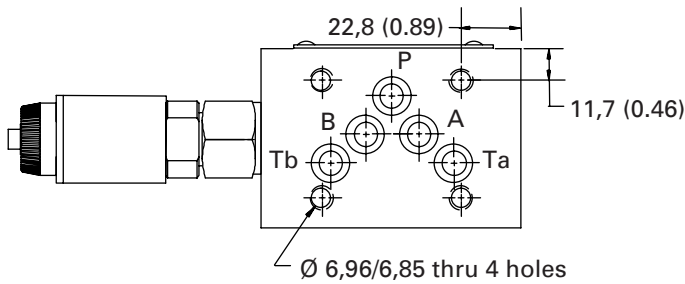
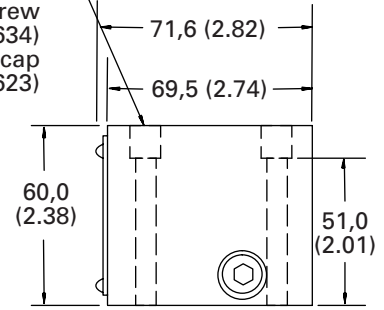

## EPV16-B-\*\*\*-S-5C-\*\*-D-(\*)--12 CETOP 5 Interface

mm (inch)

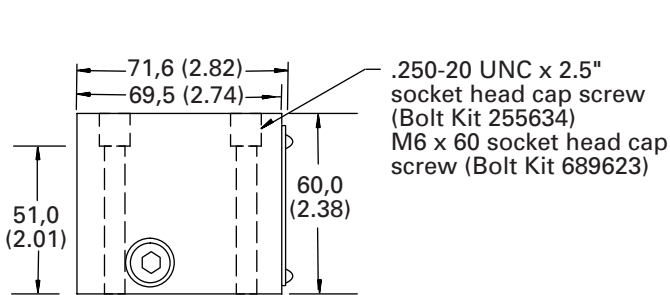

ISO-4401-AC-05-4-A  
(NFPA D05)  
mounting surface

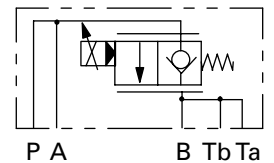
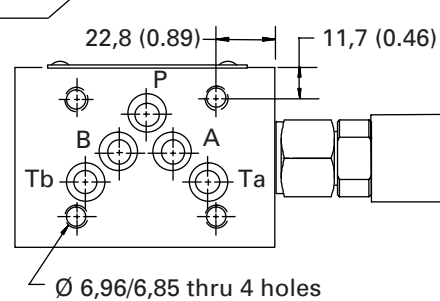
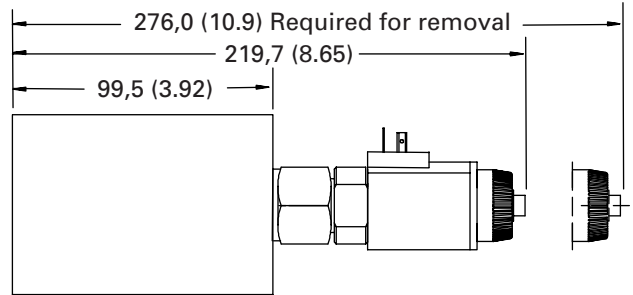

Note

CETOP 5 Seal Kit 02-  
319667

# Performance Curves

EPV16

**B**

## Typical pressure compensation

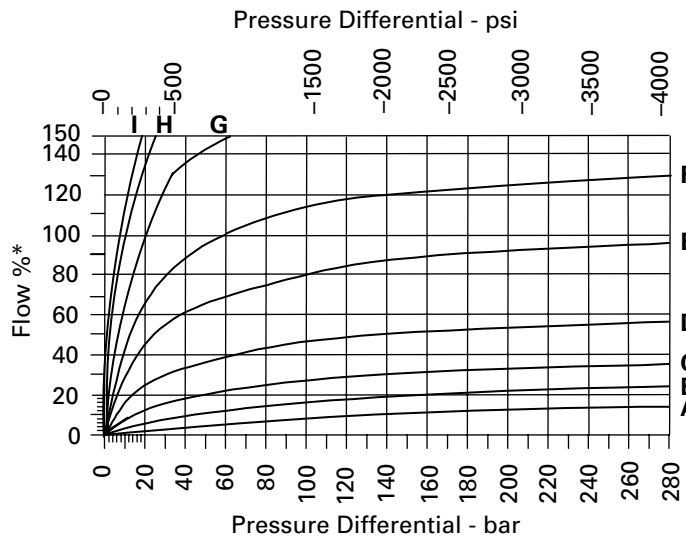

### COMMAND CURRENT

	12V	24V
A-	600 mA	300mA
B-	700 mA	350mA
C-	800 mA	400mA
D-	900 mA	450mA
E-	1000 mA	500mA
F-	1100 mA	550mA
G-	1200 mA	600mA
H-	1300 mA	650mA
I-	1400 mA	700mA

\* Flow interims of % for each poppet size

## Typical metering performance

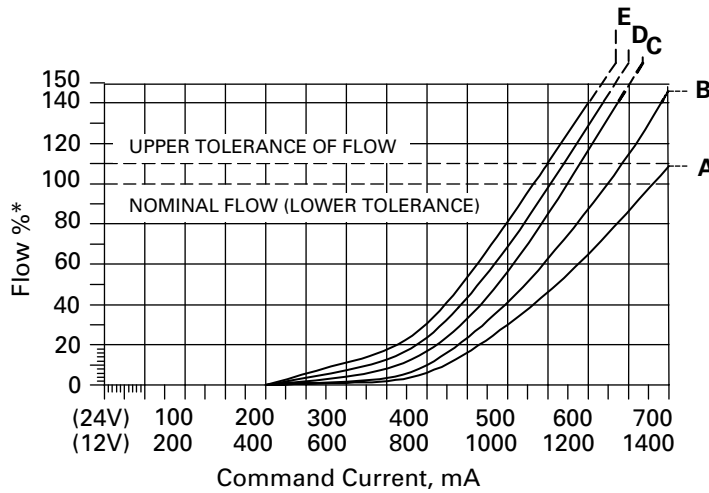

### PRESSURE DIFFERENTIAL

A-	10 bar	150 psi
B-	20 bar	300 psi
C-	50 bar	700 psi
D-	100 bar	1500 psi
E-	200 bar	3000 psi

\* Flow interims of % for each poppet size

## Step response definition of terms

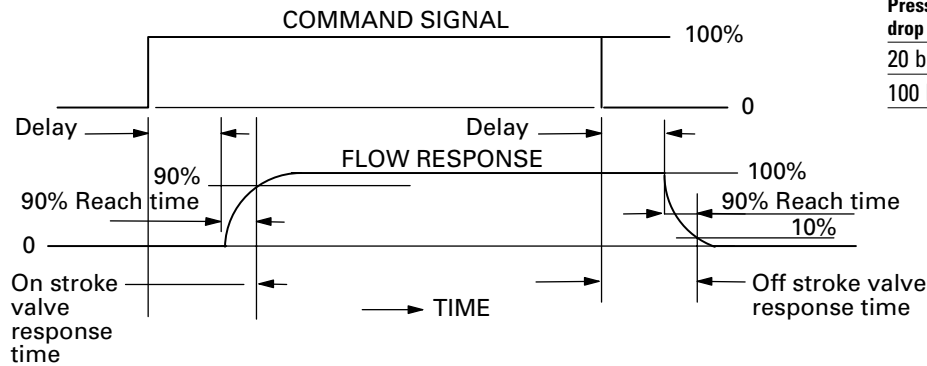

### PRESSURE DROP @ 120 L/MIN (30 USGPM)

Pressure drop $\Delta P$	On Stroke Delay/Reach 90%	Off Stroke Delay/Reach 90%
20 bar (290 psi)	24 ms/35ms	5 ms/15 ms
100 bar (1450 psi)	24 ms/17ms	5 ms/7ms

# EFV1-12\*-0

Proportional flow control valve, normally open, spool type

## Description

The EFV1-12\*-0\*\* is a normally open, unidirectional, uncompensated, spool type, two way, proportional flow control, screw-in cartridge valve.

## Operation

The valve is controlled by current supplied to the coil. At zero current, the valve is fully open from port 2 to port 3. At 1500 to 1600 mA (12V coil) the valve is fully closed. Port 1 is used for pressure balancing the spool and armature and must be blocked in all cases.

The maximum intended pressure drop is 300 PSID.

At pressure drops above 300 PSID, almost no increase in flow is obtained. The intended flow direction is from port 2 to port 3. Operation of the valve with flow from port 3 to port 2 will produce flow vs current and flow vs pressure drop curves that are significantly different from those obtained with flow from port 2 to port 3.

Since the spool and armature are pressure balanced, the operating pressure does not affect the operating characteristics of the valve. The operating point of the valve is determined only by current, pressure drop and temperature.

## Functional Symbol

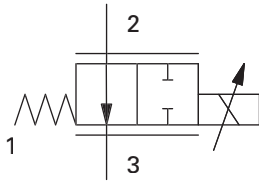

## Profile View

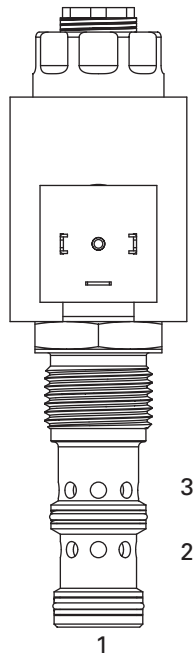

## RATINGS AND SPECIFICATIONS

*Performance data is typical with DTE 24 hydraulic fluid at 120°F*

Typical application pressure	210 bar (3000 psi)
Cartridge endurance rating	1 million cycles
Cartridge fatigue pressure rating (NFPA/T2.6.1 R2-2000)	210 bar (3000 psi)
Cartridge burst pressure rating (NFPA/T2.6.1 R2-2000)	626 bar (9090 psi)
Rated maximum flow at 300 PSID	Flow rating "A" 95 L/min (25.0 USgpm)
	Flow rating "B" 104 L/min (27.5 USgpm)
Hysteresis	1 USgpm with 400Hz PWM driver
Leakage (fully closed)	77 - 483 cm <sup>3</sup> /min (5 - 30 in <sup>3</sup> /min) at 3000 PSID
Ambient operating temperature	-30° to 90°C (-22° to 194°F)
Maximum oil temperature	120°C (248°F)
Maximum internal coil temperature	200°C (392°F)
Nominal supply voltage	12/24 V
Current to fully close valve	1500 - 1600 mA (12V coil), 750 - 800 mA (24V coil)
Recommended PWM frequency	200 - 400 Hz
Coil resistance at 20°C (68°F)	4.7 Ω (12V), 19.0 Ω (24V)
Mass	Cartridge only 0,37 kg (0.82 lb)
	Cartridge with coil and end nut 0,73 kg (1.62 lb)
Fluid	All general purpose hydraulic oils such as: MIL-H-5606, SAE 10, SAE 20, DTE 24, etc.
Filtration	Cleanliness code 18/16/13
Cavity	C-12-3
Seal kit	9900171-000 (Buna-N)
	9900172-000 (Viton®)

Viton is a registered trademark of E.I. DuPont

## Note

Port 1 is unused and must be plugged.

# Performance Curves

EFV1-12\*-0

Cartridge Only

**B**

## Max. Flow vs Pressure Drop

Flow rating "A" (Zero Current)

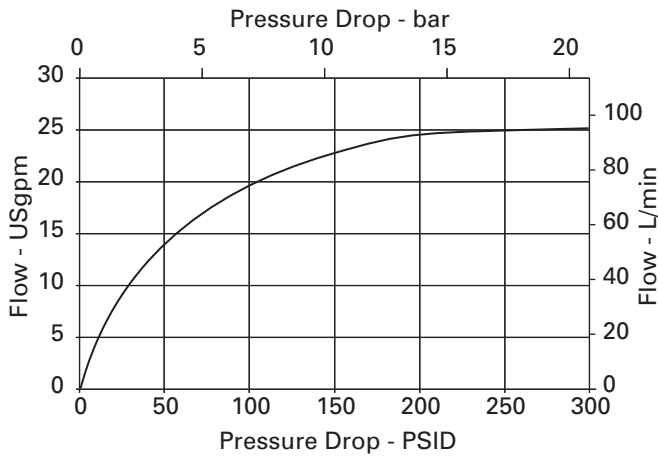

## Max. Flow vs Pressure Drop

Flow rating "B" (Zero Current)

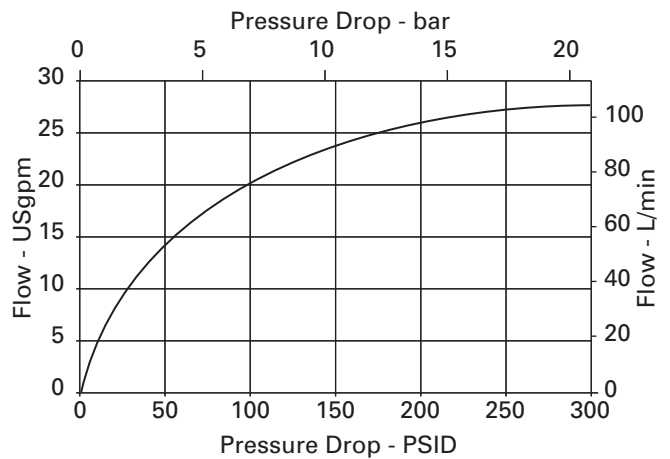

## Flow vs Current

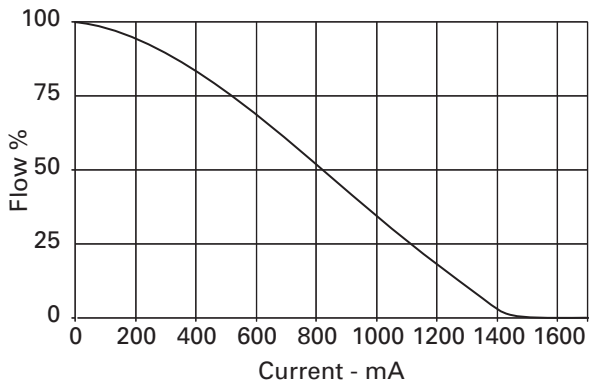

### Note

To determine operating characteristics for the flow rating selected, at a specific differential pressure, first determine maximum flow from upper curve at the differential pressure value. This will be the "100% flow" flow on the lower curve.

Parameters:  
400 Hz PWM

**EFV1 - 12 \* - 0 \* \* - \* \* \* - \* \* \* \* E \* \* - 00**

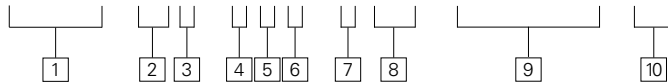

**1 Function**  
**EFV1** - Electro Proportional Flow Control Valve

**5 Flow Rating**  
**A** - 25.0 USgpm @ 300 PSID  
**B** - 27.5 USgpm @ 300 PSID

**7 Material Code**      **8 Port Code\***

**2 Size**  
**12** - 12 Size

**6 Bleed Screw and Manual Override**  
**0** - No core tube special features  
**B** - Bleed screw  
**P** - Bleed screw and push-pin type manual override  
**S** - Screw-in type manual override

		Description	Part Number	Port 1 Plug
<b>0</b>	<b>000</b>	No manifold block	—	—
<b>A</b>	<b>03G</b>	Aluminum, 3/8" BSPP	02-161816	4995036-003
	<b>04G</b>	Aluminum, 1/2" BSPP	02-161817	4995036-004
	<b>10H</b>	Aluminum, SAE 10	02-160642	02-169836
<b>S</b>	<b>12H</b>	Aluminum, SAE 12	02-160646	02-169835
	<b>03G</b>	Steel, 3/8" BSPP	02-169814	4995036-003
	<b>04G</b>	Steel, 1/2" BSPP	02-169815	4995036-004
	<b>10T</b>	Steel, SAE 10	02-161070	02-169836
	<b>12T</b>	Steel, SAE 12	02-169816	02-169835

Note: Both the manifold and port plug are required.

**3 Seals**  
**N** - Buna-N  
**V** - Viton®

**4 Logic**  
**0** - Normally Open

**9 Coil Model Code\***  
 See page C-10.

**10 Special Features**  
**00** - None

\* These model digits will not be stamped on the valve.

(Only required when valve has special features, omitted if "00.")

**Dimensions**

mm (inch)

Torque cartridge in housing

**S** - 136-149 Nm (100-110 ft. lbs)  
**A** - 108-122 Nm (80-90 ft. lbs)

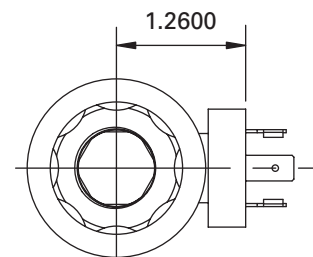
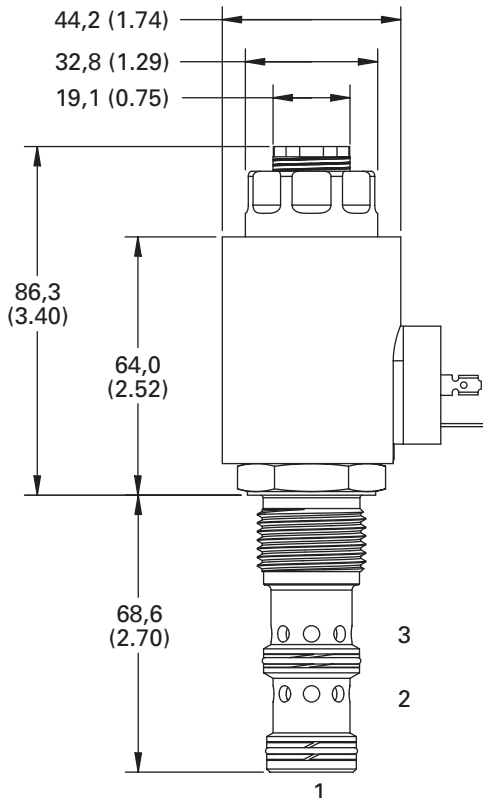

Note  
 EFV1-12 with DIN-43650 connector shown.

Note  
 Port 1 is unused and must be plugged.



# EFV1-12\*-C

Proportional flow control valve, normally closed, spool type



## Description

The EFV1-12\*-C\*\* is a normally closed, unidirectional, uncompensated, spool type, two way, proportional flow control, screw-in cartridge valve.

## Operation

The valve is controlled by current supplied to the coil. At zero current, the valve is fully closed from port 3 to port 2. At 1500 mA (12V coil) the valve is considered fully open. This is the maximum intended current level for use in applications. Port 1 is used for pressure balancing the spool and armature and must be blocked in all cases.

The maximum intended pressure drop is 300 PSID. At pressure drops above 300 PSID, almost no increase in flow is obtained. The intended flow direction is from port 3 to port 2. Operation of the valve with flow from port 2 to port 3 will produce flow vs current and flow vs pressure drop curves that are significantly different from those

obtained with flow from port 3 to port 2.

Since the spool and armature are pressure balanced, the operating pressure does not affect the operating characteristics of the valve. The operating point of the valve is determined only by current, pressure drop and temperature.

## Functional Symbol

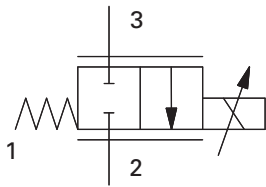

## Profile View

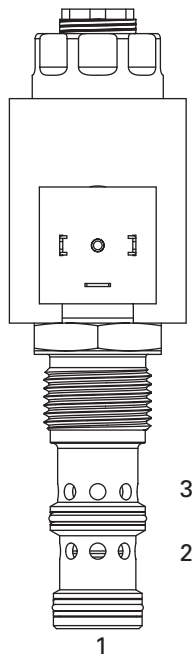

## RATINGS AND SPECIFICATIONS

*Performance data is typical with DTE 24 hydraulic fluid at 120°F*

Typical application pressure	210 bar (3000 psi)
Cartridge endurance rating	1 million cycles
Cartridge fatigue pressure rating (NFPA/T2.6.1 R2-2000)	210 bar (3000 psi)
Cartridge burst pressure rating (NFPA/T2.6.1 R2-2000)	626 bar (9090 psi)
Rated maximum flow at 300 PSID	Flow rating "A" 55L/min (14.3 USgpm) Flow rating "B" 77 L/min (20.6 USgpm)
Hysteresis	1 USgpm with 400Hz PWM driver
Leakage (fully closed)	77 - 483 cm <sup>3</sup> /min (5 - 30 in <sup>3</sup> /min) at 3000 PSID
Ambient operating temperature	-30° to 90°C (-22° to 194°F)
Maximum oil temperature	120°C (248°F)
Maximum internal coil temperature	200°C (392°F)
Nominal supply voltage	12/24 V
Current to fully close valve	1500 - 1600 mA (12V coil), 750 - 800 mA (24V coil)
Recommended dither frequency	200 - 400 Hz
Coil resistance at 20°C (68°F)	4.7 Ω (12V), 19.0 Ω (24V)
Mass	Cartridge only 0,37 kg (0.82 lb) Cartridge with coil and end nut 0,73 kg (1.62 lb)
Fluid	All general purpose hydraulic oils such as: MIL-H-5606, SAE 10, SAE 20, DTE 24, etc.
Filtration	Cleanliness code 18/16/13
Cavity	C-12-3
Seal kit	9900171-000 (Buna-N) 9900172-000 (Viton®)

Viton is a registered trademark of E.I. DuPont

## Note

Port 1 is unused and must be plugged.

# Performance Curves

EFV1-12\*-C

Cartridge Only

## Max. Flow vs Pressure Drop

Flow rating "A" (Valve fully open)

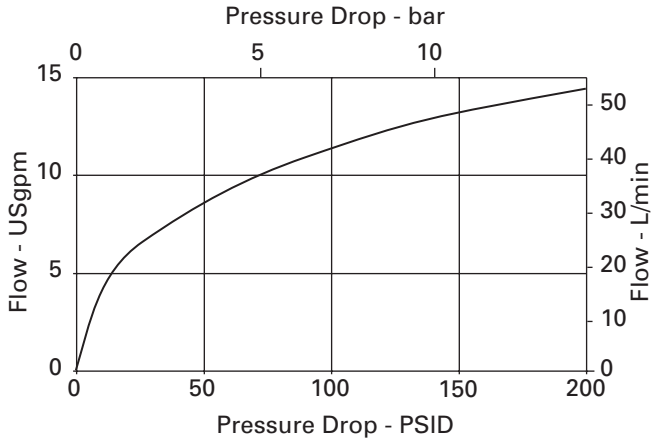

## Max. Flow vs Pressure Drop

Flow rating "B" (Valve fully open)

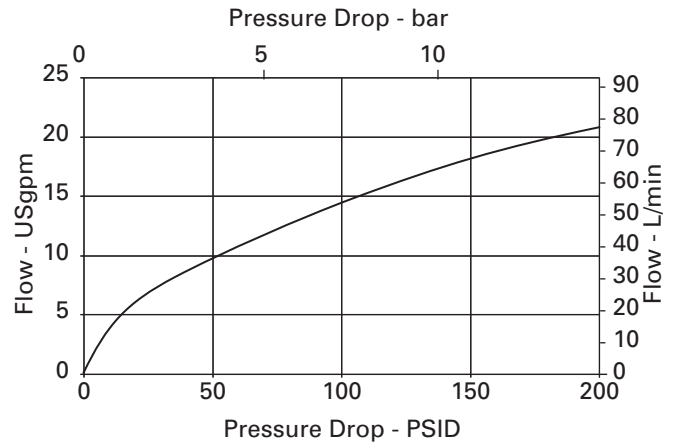

## Flow vs Current

(Flow rating "B")

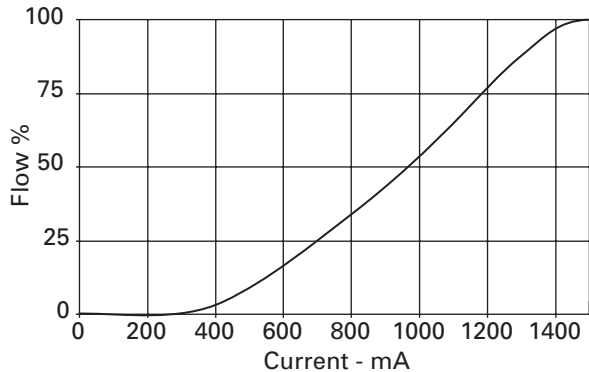

### Note

To determine operating characteristics for the flow rating selected, at a specific differential pressure, first determine maximum flow from upper curve at the differential pressure value. This will be the "100%" flow on the lower curve.

Parameters:  
400 Hz PWM

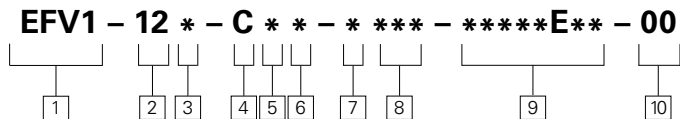

**1 Function**  
**EFV1** - Electro Proportional Flow Control Valve

**2 Size**  
**12** - 12 Size

**3 Seals**  
**N** - Buna-N  
**V** - Viton®

**4 Logic**  
**C** - Normally Closed

**5 Flow Rating**  
**A** - 14.3 USgpm @ 300 PSID  
**B** - 20.6 USgpm @ 300 PSID

**6 Bleed Screw and Manual Override**  
**0** - No core tube special features  
**B** - Bleed screw  
**P** - Bleed screw and push-pin type manual override  
**S** - Screw-in type manual override

7 Material Code	8 Port Code*	Description	Part Number	Port 1 Plug
<b>0</b>	<b>000</b>	No manifold block	N/A	NA
<b>A</b>	<b>03G</b>	Aluminum, 3/8" BSPP	02-161816	4995036-003
	<b>04G</b>	Aluminum, 1/2" BSPP	02-161817	4995036-004
	<b>10H</b>	Aluminum, SAE 10	02-160642	02-169836
<b>S</b>	<b>12H</b>	Aluminum, SAE 12	02-160646	02-169835
	<b>03G</b>	Steel, 3/8" BSPP	02-169814	4995036-003
	<b>04G</b>	Steel, 1/2" BSPP	02-169815	4995036-004
	<b>10T</b>	Steel, SAE 10	02-161070	02-169836
	<b>12T</b>	Steel, SAE 12	02-169816	02-169835

Note: Both the manifold and port plug are required.

**9 Coil Model Code\***  
 See page C-10.  
 \* These model digits will not be stamped on the valve.

**10 Special Features**  
**00** - None  
 (Only required when valve has special features, omitted if "00.")

**Dimensions**  
 mm (inch)  
 Torque cartridge in housing  
**S** - 136-149 Nm (100-110 ft. lbs)  
**A** - 108-122 Nm (80-90 ft. lbs)

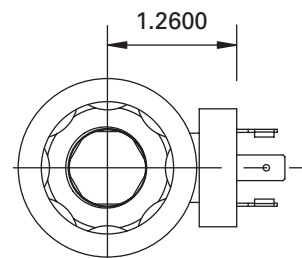
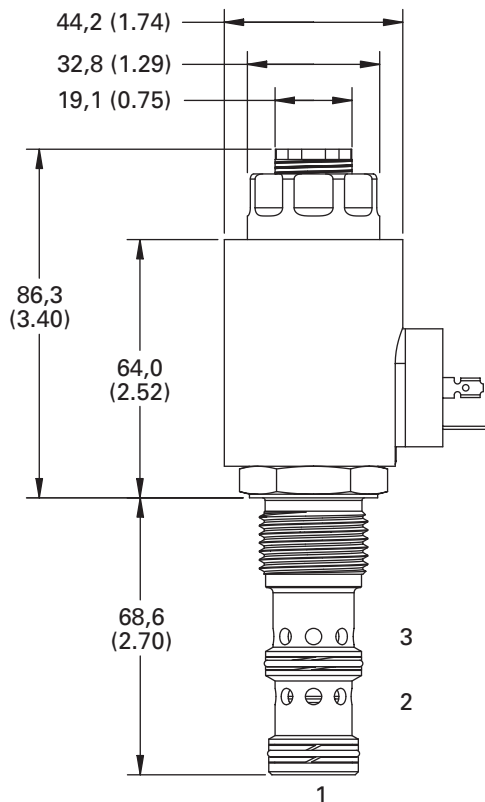

Note: EFV1-12 with DIN-43650 connector shown.

Note  
 Port 1 is unused and must be plugged.

# ERV1-10

Proportionally controlled pressure relief valve

## Description

The ERV1-10 is an electric, proportionally controlled, internally pilot operated, spool type, screw-in relief valve.

## Operation

This valve remains closed between port 1 and 2 until the predetermined pressure setting has been reached at port 1, overcoming the electrical force and opening the spool to allow flow from port 1 to port 2.

## Functional Symbol

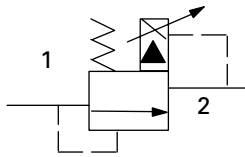

## Sectional View

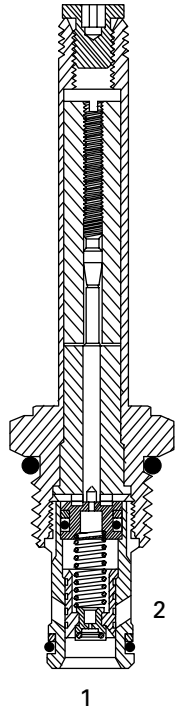

## RATINGS AND SPECIFICATIONS

*Performance data is typical with fluid at 21,8 cSt (105 SUS) and 49°C (120°F)*

Typical application pressure (all ports)	2 - 210 bar (30 - 3000 psi)
Cartridge fatigue pressure (infinite life)	210 bar (3000 psi)
Rated flow	3,8 - 60,0 L/min (1 - 15 USgpm)
Cavity	C-10-2
Standard housing materials	Aluminum
Temperature range	-40° to 120°C (-40° to 248°F)
Fluids	All general purpose hydraulic fluids such as: MIL-H-5606, SAE 10, SAE 20, etc.
Filtration	Cleanliness code 18/16/13
Weight cartridge and coil	0,44 kg (0.98 lbs)
Seal kits	565803 (Buna-N) 565086 (Viton®)

Viton is a registered trademark of E.I. DuPont

## Pressure Override Characteristics

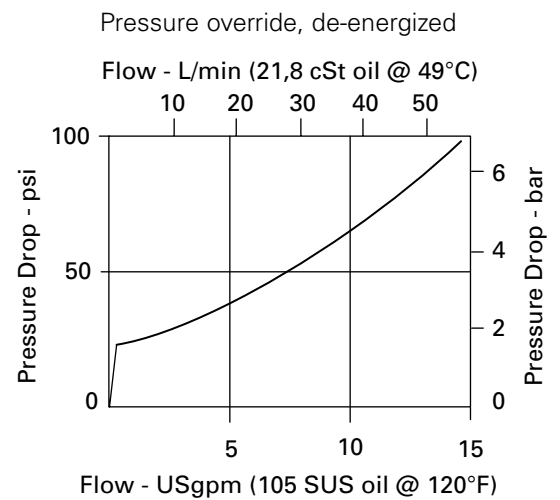
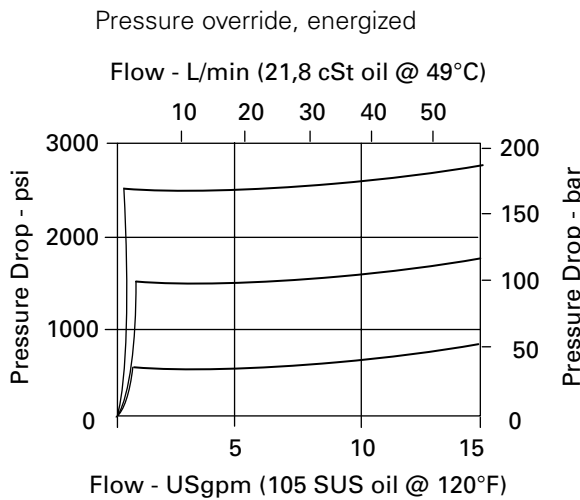

**ERV1 - 10 (V) - \*\* - \*\* - \*\*\* - \* - 00**

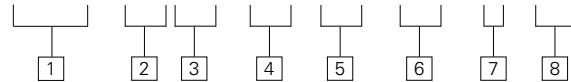

**1 Function**

**ERV1** - Proportional relief valve

**2 Size**

**10** - 10 Size

**3 Seals**

**Blank** - Buna-N  
**V** - Viton®

**4 Maximum pressure (factory set)**

Customer to specify settings in increments of 7 bar (100 psi) and coded in hundreds of psi within the 35-210 bar range (500-3000 psi) range.

Example: **5** - 35,0 (500 psi)

**6 Voltage rating**

- 00** - No coil
- 12D** - 12VDC
- 24D** - 24VDC
- 12B** - 12VDC/w diode\*
- 24B** - 24VDC/w diode\*

\*Optional arc suppressing diode.

Note: This valve uses the standard 10 series 20 W coils, see page C-5 for coil part numbers and specifications.

**5 Port size**

**0** - Cartridge only

CODE	PORT SIZE	HOUSING NUMBER
<b>6T</b>	SAE 6	566151*
<b>2G</b>	1/4" BSPP	876702
<b>3G</b>	3/8" BSPP	876703
<b>6H</b>	SAE 6	876700
<b>8H</b>	SAE 8	876701

\*Light duty housing. See section J for housings.

**7 Connector Types**

- Blank** - No coil
- G** - DIN 43650
- P** - 1/2" NPT conduit
- Q** - Spade terminals
- W** - Leadwire
- N** - Deutch
- Y** - Amp JR

**8 Special Features**

- 00** - None
- (Only required when valve has special features, omitted if "00.")



**WARNING**

Maintain 5-8 Nm (4-6 ft. lbs) maximum torque on valve tube nut. Over tightening may cause valve failure.

**Dimensions**

mm (inch)  
Torque cartridge in aluminum housing 47-54 Nm (35-40 ft. lbs)

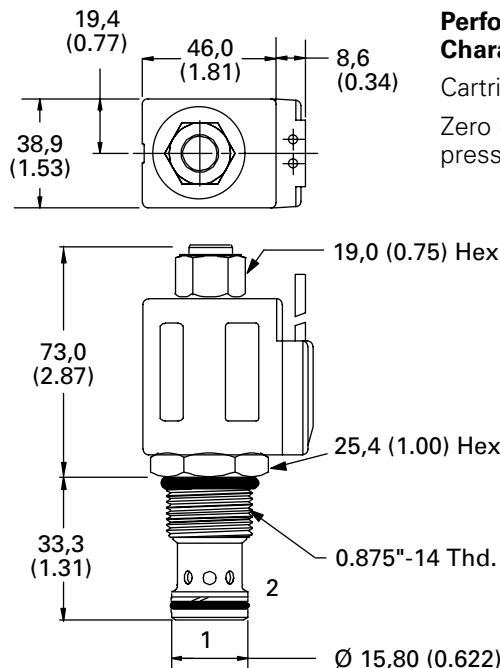

Valve is shown with "W" coil.

**Performance Characteristics**

Cartridges only  
Zero outlet pressure

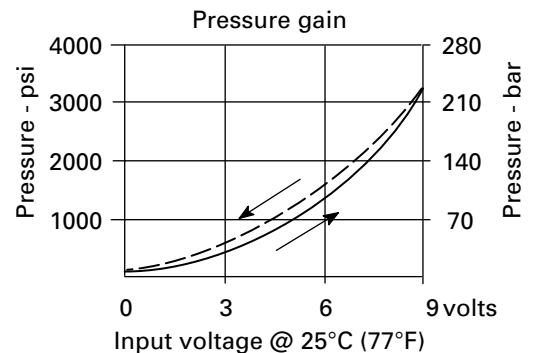
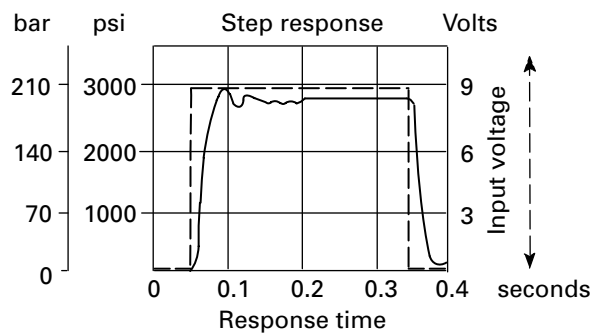

# ERV1-16

Proportionally controlled pressure relief valve

## Description

The ERV1-16 is an electric, proportionally controlled, internally pilot operated, spool type, screw-in relief valve.

## Operation

This valve remains closed between port 1 and 2 until the predetermined pressure setting has been reached at port 1, overcoming the electrical force and unseating the spool to allow flow from port 2.

## Functional Symbol

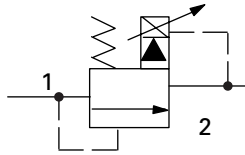

## Sectional View

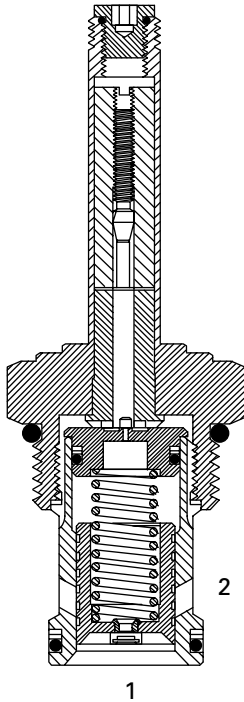

## RATINGS AND SPECIFICATIONS

*Performance data is typical with fluid at 21,8 cSt (105 SUS) and 49°C (120°F)*

Typical application pressure (all ports)	3,5 - 210 bar (50 - 3000 psi)
Cartridge fatigue pressure (infinite life)	210 bar (3000 psi)
Rated flow	7,6 - 132,0 L/min (2 - 35 USgpm)
Cavity	C-16-2
Standard housing materials	Aluminum
Temperature range	-40° to 120°C (-40° to 248°F)
Fluids	All general purpose hydraulic fluids such as: MIL-H-5606, SAE 10, SAE 20, etc.
Filtration	Cleanliness code 18/16/13
Weight cartridge and coil	0,44 kg (0.98 lbs)
Seal kits	565810 (Buna-N) 889609 (Viton®)

Viton is a registered trademark of E.I. DuPont

## Pressure Override Characteristics

Pressure override, energized

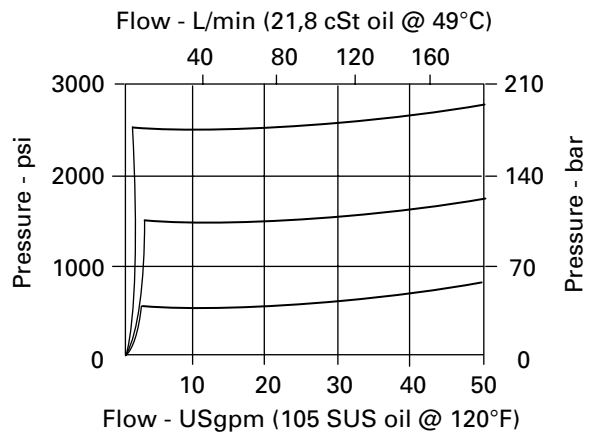

Pressure override, de-energized

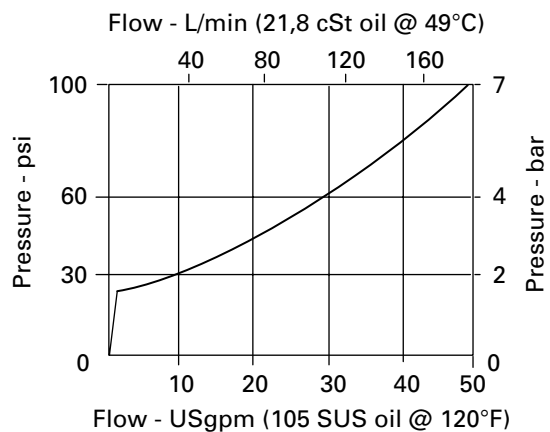

**ERV1 - 16 (V) - \*\* - \*\*\* - \*\*\* - \* - 00**

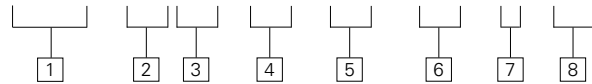

**1 Function**

**ERV1** - Proportional relief valve

**2 Size**

**16** - 16 Size

**3 Seals**

**Blank** - Buna-N  
**V** - Viton®



**WARNING**

Maintain 5-8 Nm (4-6 ft. lbs) maximum torque on valve tube nut. Over tightening may cause valve failure.

**4 Maximum pressure (factory set)**

Customer to specify settings in increments of 7 bar (100 psi) and coded in hundreds of psi within the 35-210 bar range (500-3000 psi) range.

Example: **5** - 35,0 (500 psi)

**6 Voltage rating**

- 00** - No coil
- 12D** - 12VDC
- 24D** - 24VDC
- 12B** - 12VDC/w diode\*
- 24B** - 24VDC/w diode\*

\*Optional arc suppressing diode.

Note: This valve uses the standard 10 series 20 W coils, see page C-5 for coil part numbers and specifications.

**5 Port size**

**0** - Cartridge only

CODE	PORT SIZE	HOUSING NUMBER
<b>12T</b>	SAE 12	566149*
<b>4G</b>	1/2" BSPP	876716
<b>6G</b>	3/4" BSPP	876718
<b>10H</b>	SAE 10	876717
<b>12H</b>	SAE 12	566113

\*Light duty housing. See section J for housings.

**7 Connector Types**

- Blank** - No coil
- G** - DIN 43650
- P** - 1/2" NPT conduit
- Q** - Spade terminals
- W** - Leadwire
- N** - Deutch
- Y** - Amp JR

**8 Special Features**

- 00** - None
- (Only required when valve has special features, omitted if "00.")

**Dimensions**

mm (inch)  
Torque cartridge in aluminum housing  
108-122 Nm (80-90 ft. lbs)

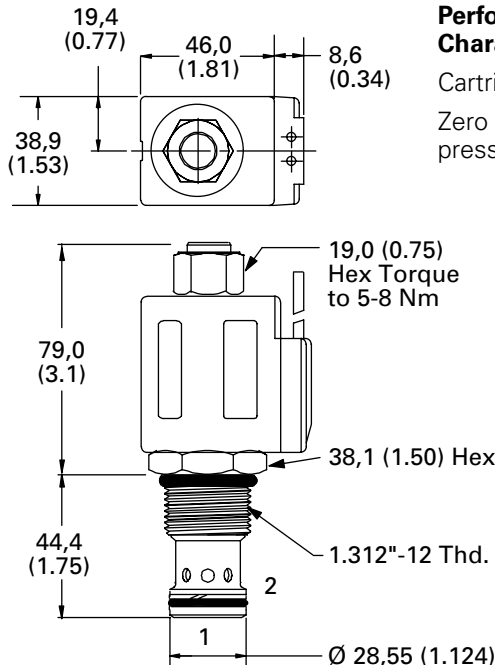

Valve is shown with "W" coil.

**Performance Characteristics**

Cartridges only  
Zero outlet pressure

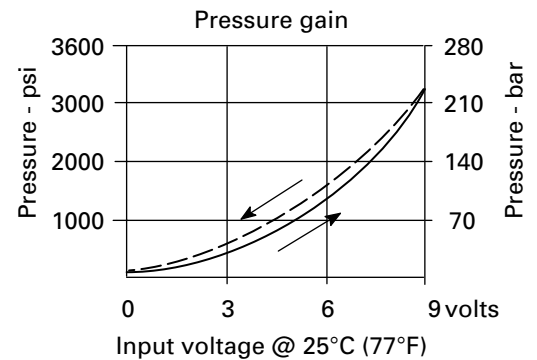
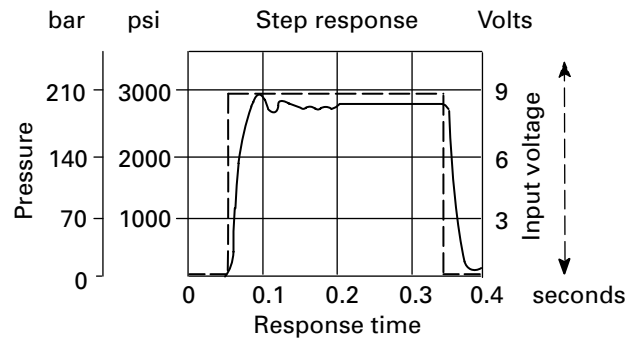

# ERV2-10

Proportionally controlled pressure relief valve

## Description

The ERV2-10 is an electric, proportionally controlled, direct acting, spool type, screw-in relief valve.

## Operation

This valve remains closed between port 1 and 2 until the predetermined pressure setting has been reached at port 1, overcoming the electrical force and unseating the spool to allow flow from port 2.

## Functional Symbol

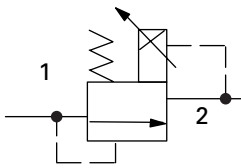

## Sectional View

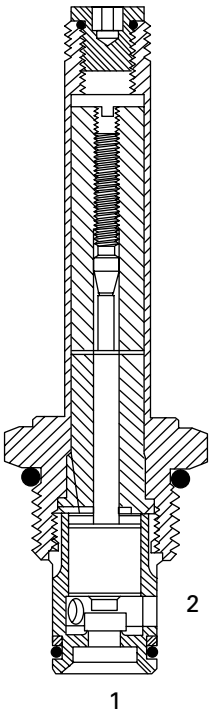

## RATINGS AND SPECIFICATIONS

*Performance data is typical with fluid at 21,8 cSt (105 SUS) and 49°C (120°F)*

Typical application pressure (all ports)	0 - 35 bar (0 - 500 psi)
Cartridge fatigue pressure (infinite life)	35 bar (500 psi)
Rated flow	0,2 - 2,8 L/min (0.05 - 0.75 USgpm)
Cavity	C-10-2
Standard housing materials	Aluminum
Temperature range	-40° to 120°C (-40° to 248°F)
Fluids	All general purpose hydraulic fluids such as: MIL-H-5606, SAE 10, SAE 20, etc.
Filtration	Cleanliness code 18/16/13
Weight cartridge and coil	0,43 kg (0.95 lbs)
Seal kits	565810 (Buna-N) 889609 (Viton®)

*Viton is a registered trademark of E.I. DuPont*

## Pressure Override Characteristics

Pressure override, energized

Flow - L/min (21,8 cSt oil @ 49°C)

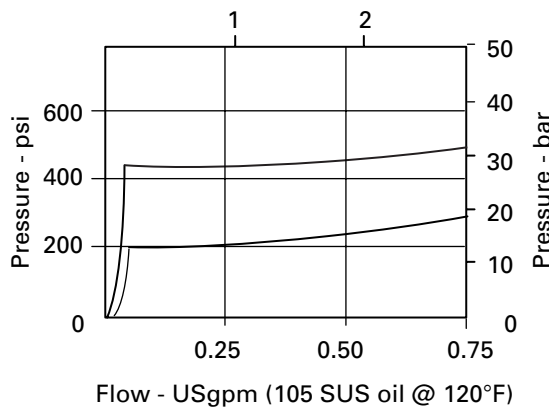

Pressure override, de-energized

Flow - L/min (21,8 cSt oil @ 49°C)

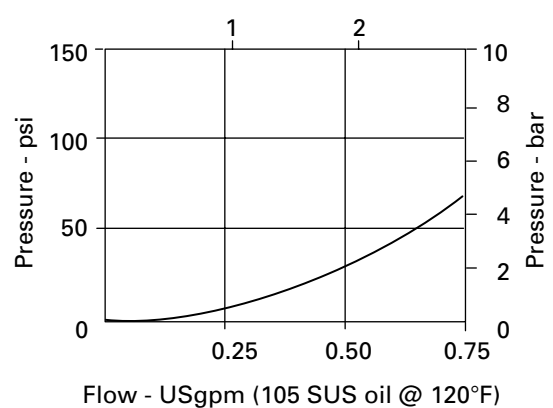



**ERV2 - 10 (V) - \*\* - \*\* - \*\*\* - \* - 00**

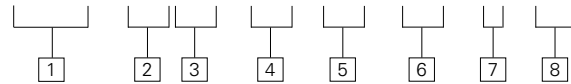

- 1 Function**  
ERV2 - Proportional relief valve

---

- 2 Size**  
10 - 10 Size

---

- 3 Seals**  
Blank - Buna-N  
V - Viton®

- 4 Maximum pressure (factory set)**  
Customer to specify settings in increments of 7 bar (100 psi) and coded in hundreds of psi within the 0-35 bar range (0-500 psi) range.  
Example: 5 - 35,0 (500 psi)

**5 Port size**  
0 - Cartridge only

CODE	PORT SIZE	HOUSING NUMBER
6T	SAE 6	566151*
2G	1/4" BSPP	876702
3G	3/8" BSPP	876703
6H	SAE 6	876700
8H	SAE 8	876701

- 6 Voltage rating**  
00 - No coil  
12D - 12VDC  
24D - 24VDC  
12B - 12VDC/w diode\*  
24B - 24VDC/w diode\*  
\*Optional arc suppressing diode.  
Note: This valve uses the standard 10 series 20 W coils, see page C-5 for coil part numbers and specifications.

- 7 Connector Types**  
Blank - No coil  
G - DIN 43650  
P - 1/2" NPT conduit  
Q - Spade terminals  
W - Leadwire  
N - Deutch  
Y - Amp JR
- 8 Special Features**  
00 - None  
(Only required when valve has special features, omitted if "00.")

**WARNING**  
Maintain 5-8 Nm (4-6 ft. lbs) maximum torque on valve tube nut. Over tightening may cause valve failure.

**Dimensions**  
mm (inch)  
Torque cartridge in aluminum housing  
47-54 Nm (35-40 ft. lbs)

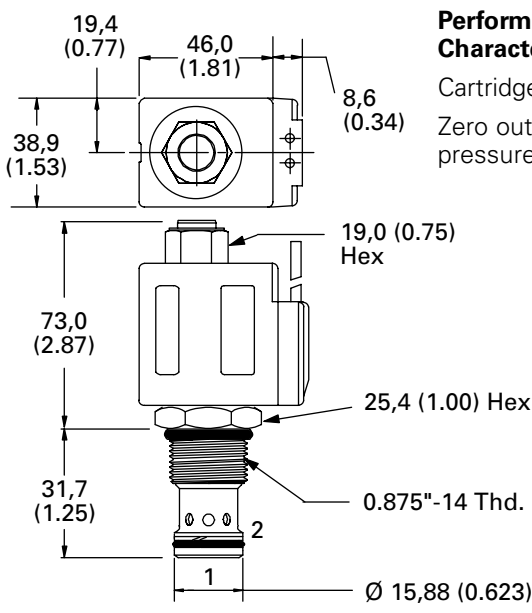

**Performance Characteristics**  
Cartridges only  
Zero outlet pressure

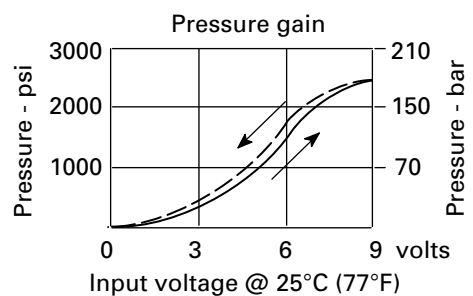
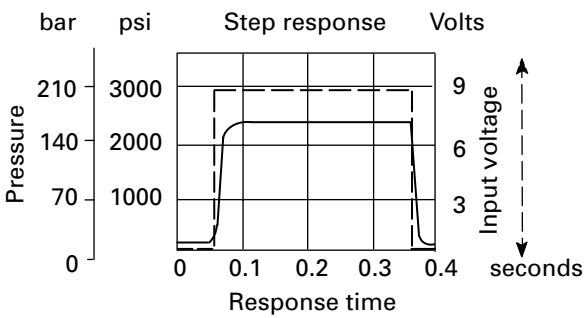

Valve is shown with "W" coil.

# EPRV2-8

Proportional pressure reducing-relieving valve

## Description

The EPRV2-8 is a proportional, pressure reducing-relieving, sliding spool, electrically controlled, screw-in cartridge type valve.

## Operation

In the de-energized position, pressure inlet port 2 is closed and reduced pressure port 1 is open to return port 3. As electrical current

is increased, port 2 opens to port 1 and port 3 closes, proportionally increasing pressure at port 1. If the pressure at port 1 exceeds

the setting of the valve, the spool will shift further and relieve to port 3.

## Functional Symbol

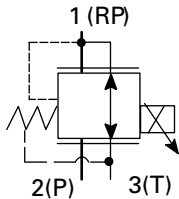

## Sectional View

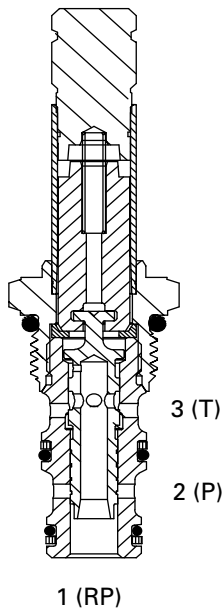

## RATINGS AND SPECIFICATIONS

*Performance data is typical with fluid at 21,8 cSt (105 SUS) and 49°C (120°F)*

Maximum inlet pressure	35 bar (500 psi)
Cartridge fatigue pressure (infinite life)	35 bar (500 psi)
Reduced pressure range	0 - 22 bar (0 - 320 psi)
Maximum operating flow	7,6 L/min (2 USgpm)
Cavity	C-8-3
Standard housing materials	Aluminum
Temperature range	-40° to 120°C (-40° to 248°F)
Fluids	All general purpose hydraulic fluids such as: MIL-H-5606, SAE 10, SAE 20, etc.
Filtration	Cleanliness code 18/16/13
Recommended PWM frequency	150 Hz
Hysteresis @ 150 Hz PWM	5%
Weight including coil	0,29 kg (0.64 lbs)
Seal kits	02-179451 (Buna-N) 02-179452 (Viton®)

Viton is a registered trademark of E.I. DuPont

## Pressure Characteristics

Pressure drops vs flow

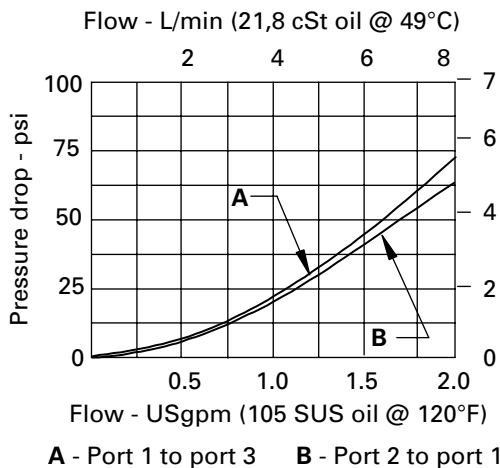

Pressure drops vs flow

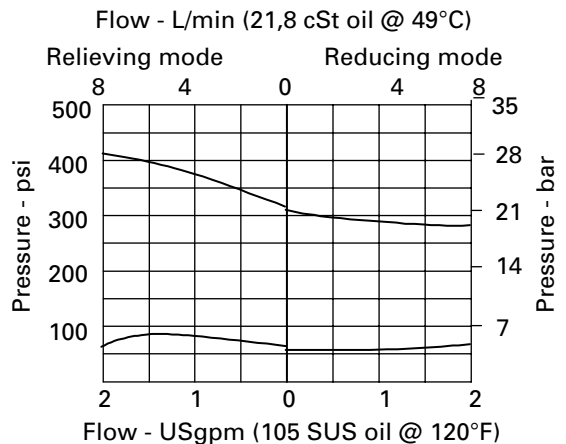

**EPRV2 - 8 (V) - (A) - \*\* - \*\*\* - \* \* - 00**

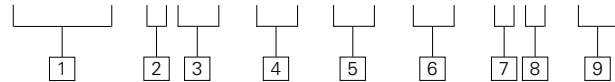

**1 Function**  
**EPRV2** - Proportional reducing/relieving valve

**2 Size**  
**8** - 8 Size

**3 Seals**  
**Blank** - Buna-N  
**V** - Viton®

**4 Valve housing material**  
 Omit for cartridge only  
**A** - Aluminum

**6 Voltage rating**  
**00** - No coil  
**12D** - 12VDC  
**24D** - 24VDC  
**12B** - 12VDC/w diode\*  
**24B** - 24VDC/w diode\*

\*Optional arc suppressing diode.  
 Note: This valve uses the standard 8 series, 16 W coils, see page C-3 for part numbers and specifications.

**5 Port size**  
**0** - Cartridge only

CODE	PORT SIZE	HOUSING NUMBER
4T	SAE 4	02-160741
6T	SAE 6	02-160742
2G	1/4" BSPP	02-160739
3G	3/8" BSPP	02-160740

See section J for housings.

**7 Connector Types**  
**Blank** - No coil  
**G** - DIN 43650  
**P** - 1/2" NPT conduit  
**Q** - Spade terminals  
**W** - Leadwire  
**N** - Deutch  
**Y** - Amp JR

**8 Coil**  
**S** - 8 series, 16 W

**9 Special Features**  
**00** - None  
 (Only required when valve has special features, omitted if "00.")

**WARNING**  
 Maintain 5-8 Nm (4-6 ft. lbs) maximum torque on valve tube nut. Over tightening may cause valve failure.

**Dimensions**

mm (inch)  
 Torque cartridge in aluminum or steel housing 34-41 Nm (25-30 ft. lbs)

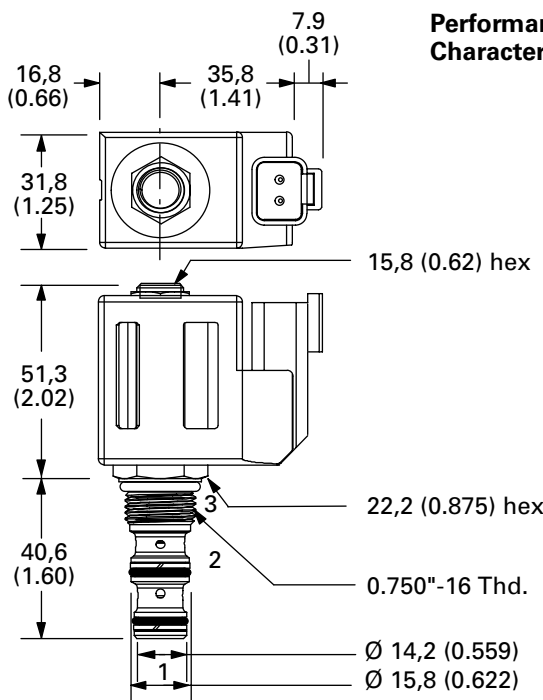

Valve is shown with "N" coil.

**Performance Characteristics**

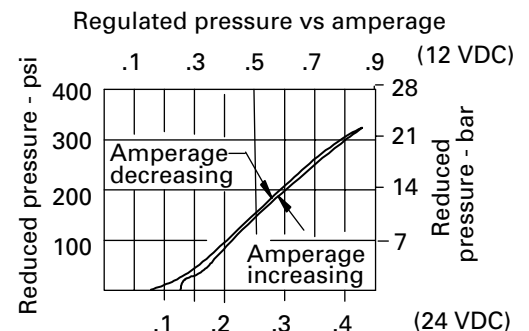
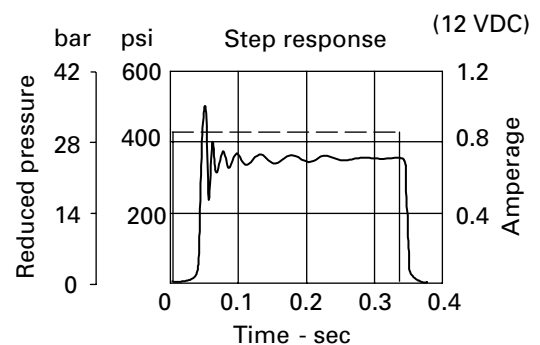

# EPRV1-10

Proportional pressure reducing-relieving valve

## Description

The EPRV1-10 is an electric, proportionally controlled, internally pilot operated, spool type, screw-in relief valve.

## Operation

This valve remains open from port 2 to port 1 (port 3 must be vented). Once the predetermined pressure is reached at port 1,

the spool shifts to restrict the inlet flow at port 2, which regulates the pressure at port 1. If the pressure at port 1

exceeds the setting of the valve, the spool will shift farther and relieve to port 3.

## Functional Symbol

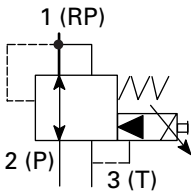

## Sectional View

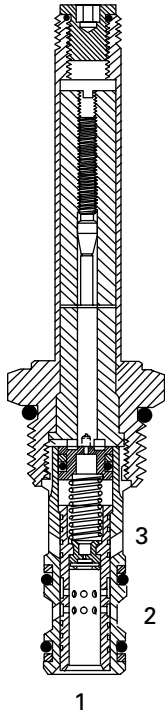

## RATINGS AND SPECIFICATIONS

*Performance data is typical with fluid at 21,8 cSt (105 SUS) and 49°C (120°F)*

Typical application pressure (all ports)	3,5 - 35 bar (50 - 500 psi)
Cartridge fatigue pressure (infinite life)	35 bar (500 psi)
Rated flow	0 - 7,6 L/min (0 - 2.0 USgpm)
Cavity	C-10-3
Standard housing materials	Aluminum
Temperature range	-40° to 120°C (-40° to 248°F)
Fluids	All general purpose hydraulic fluids such as: MIL-H-5606, SAE 10, SAE 20, etc.
Filtration	Cleanliness code 18/16/13
Weight cartridge and coil	0,44 kg (0.98 lbs)
Seal kits	565804 (Buna-N) 889599 (Viton®)

Viton is a registered trademark of E.I. DuPont

## Pressure Override Characteristics

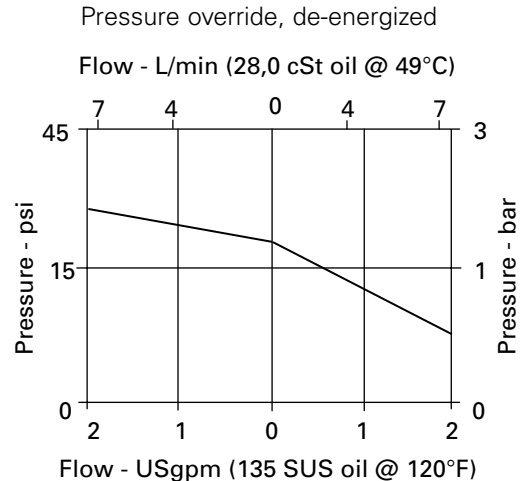
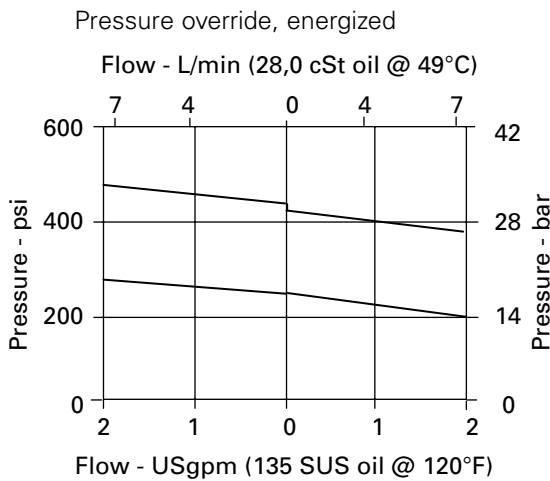

**EPRV1 - 10 (V) - \*\* - \*\* - \*\*\* \* - 00**

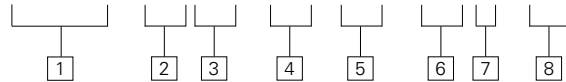

**1 Function**

**EPRV1** - Proportional reducing/relieving valve

**2 Size**

**10** - 10 Size

**3 Seals**

**Blank** - Buna-N  
**V** - Viton®

**4 Maximum pressure (factory set)**

Customer to specify settings in increments of 7 bar (100 psi) and coded in hundreds of psi within the 14-35 bar range (200-500 psi) range.

Example: **5** - 35,0 (500 psi)

**6 Voltage rating**

- 00** - No coil
- 12D** - 12VDC
- 24D** - 24VDC
- 36D** - 36VDC
- 12B** - 12VDC/w diode\*
- 24B** - 24VDC/w diode\*

\*Optional arc suppressing diode.

Note: This valve uses the standard 10 series 20 W coils, see page C-5 for coil part numbers and specifications.

**5 Port size**

**0** - Cartridge only

CODE	PORT SIZE	HOUSING NUMBER
<b>3B</b>	3/8" BSPP	02-173358*
<b>6T</b>	SAE 6	566162*
<b>2G</b>	1/4" BSPP	876702
<b>3G</b>	3/8" BSPP	876714
<b>6H</b>	SAE 6	876704
<b>8H</b>	SAE 8	876711

\*Light duty housing. See section J for housings.

**7 Connector Types**

- Blank** - No coil
- G** - DIN 43650
- P** - 1/2" NPT conduit
- Q** - Spade terminals
- W** - Leadwire
- N** - Deutch
- Y** - Amp JR

**8 Special Features**

**00** - None  
(Only required when valve has special features, omitted if "00.")



**WARNING**

Maintain 5-8 Nm (4-6 ft. lbs) maximum torque on valve tube nut. Over tightening may cause valve failure.

**Dimensions**

mm (inch)  
Torque cartridge in aluminum housing  
47-54 Nm  
(35-40 ft. lbs)

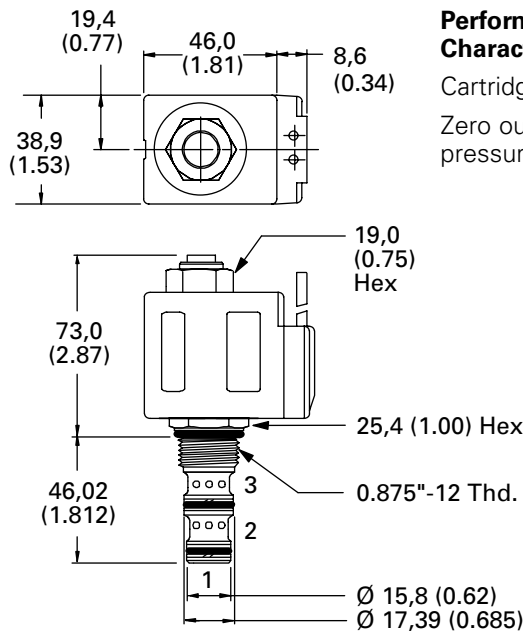

Valve is shown with "W" coil.

**Performance Characteristics**

Cartridges only  
Zero outlet pressure

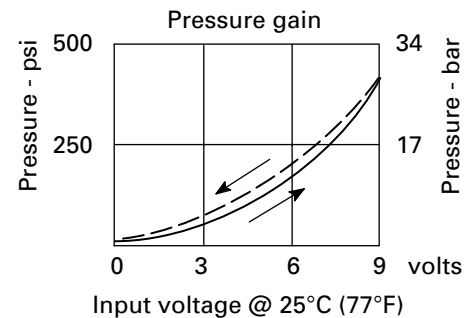
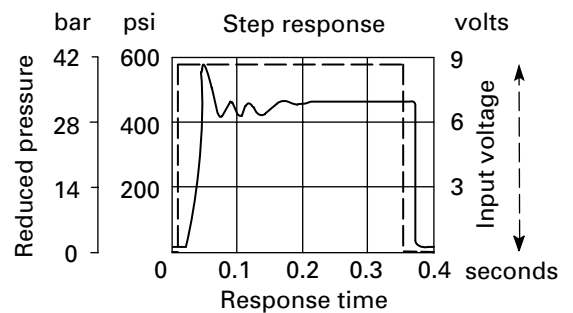

# EPRV1-16

Proportional pressure  
reducing-relieving valve

## Description

The EPRV1-16 is an electric, proportionally controlled, internally pilot operated, spool type, screw-in relief valve.

## Operation

This valve remains open from port 2 to port 1 (port 3 must be vented). Once the predetermined pressure is

reached at port 1, the spool shifts to restrict the inlet flow at port 2, which regulates the pressure at port 1.

If the pressure at port 1 exceeds the setting of the valve, the spool will shift farther and relieve to port 3.

## Functional Symbol

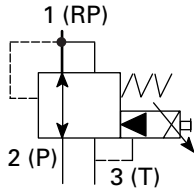

## Sectional View

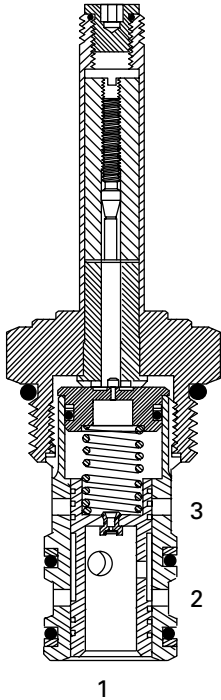

## RATINGS AND SPECIFICATIONS

*Performance data is typical with fluid at 21,8 cSt (105 SUS) and 49°C (120°F)*

Typical application pressure (all ports)	3,5 - 35 bar (0 - 500 psi)
Cartridge fatigue pressure (infinite life)	35 bar (500 psi)
Rated flow	0 - 38,0 L/min (0 - 10 USgpm)
Cavity	C-16-3
Standard housing materials	Aluminum
Temperature range	-40° to 120°C (-40° to 248°F)
Fluids	All general purpose hydraulic fluids such as: MIL-H-5606, SAE 10, SAE 20, etc.
Filtration	Cleanliness code 18/16/13
Weight cartridge and coil	0,9 kg (2.00 lbs)
Seal kits	565811 (Buna-N) 889599 (Viton®)

Viton is a registered trademark of E.I. DuPont

## Pressure Override Characteristics

Pressure override, energized

Flow - L/min (28,0 cSt oil @ 49°C)

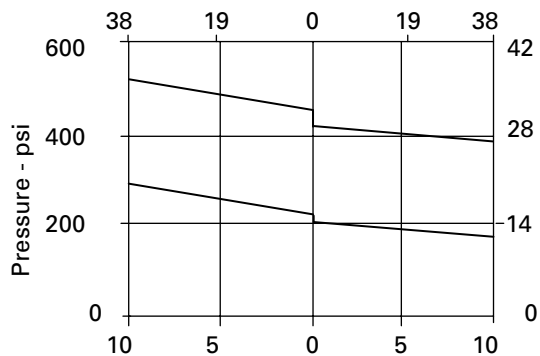

Flow - USgpm (135 SUS oil @ 120°F)

Pressure override, de-energized

Flow - L/min (28,0 cSt oil @ 49°C)

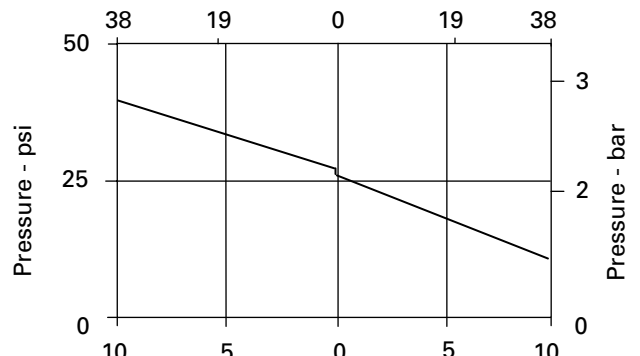

Flow - USgpm (135 SUS oil @ 120°F)

**EPRV1 - 16 (V) - \*\* - \*\*\* - \*\*\* - \* - 00**

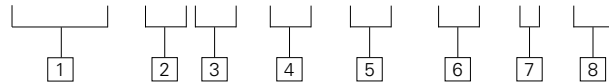

**1 Function**  
**EPRV1** - Proportional reducing/relieving valve

**2 Size**  
**16** - 16 Size

**3 Seals**  
**Blank** - Buna-N  
**V** - Viton®

**WARNING**  
 Maintain 5-8 Nm (4-6 ft. lbs) maximum torque on valve tube nut. Over tightening may cause valve failure.

**4 Maximum pressure (factory set)**  
 Customer to specify settings in increments of 7 bar (100 psi) and coded in hundreds of psi within the 14-35 bar range (200-500 psi) range.  
 Example: **5** - 35,0 (500 psi)

**6 Voltage rating**  
**00** - No coil  
**12D** - 12VDC  
**24D** - 24VDC  
**36D** - 36VDC  
**12B** - 12VDC/w diode\*  
**24B** - 24VDC/w diode\*  
 \*Optional arc suppressing diode.  
 Note: This valve uses the standard 10 series 20 W coils, see page C-5 for coil part numbers and specifications.

**5 Port size**  
**0** - Cartridge only

CODE	PORT SIZE	HOUSING NUMBER
<b>6B</b>	3/4" BSPP	02-175465*
<b>12T</b>	SAE 12	566162*
<b>6G</b>	3/4" BSPP	876722
<b>10H</b>	SAE 10	876721
<b>12H</b>	SAE 12	876723

\*Light duty housing. See section J for housings.

**7 Connector Types**  
**Blank** - No coil  
**G** - DIN 43650  
**P** - 1/2" NPT conduit  
**Q** - Spade terminals  
**W** - Leadwire  
**N** - Deutch  
**Y** - Amp JR

**8 Special Features**  
**00** - None  
 (Only required when valve has special features, omitted if "00.")

**Dimensions**  
 mm (inch)  
 Torque cartridge in aluminum housing  
 108-122 Nm (80-90 ft. lbs)

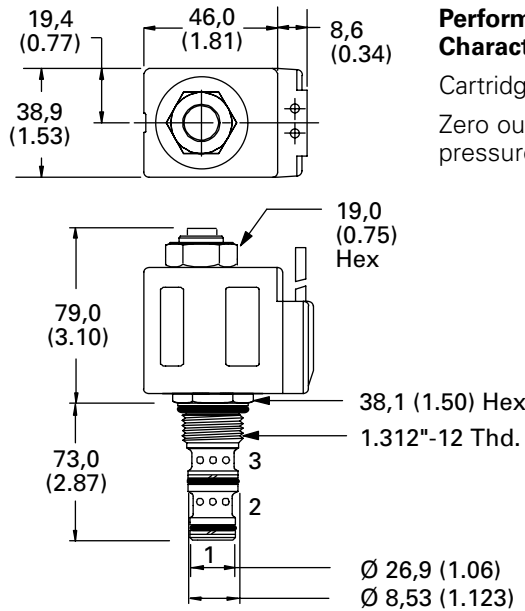

Valve is shown with "W" coil.

**Performance Characteristics**  
 Cartridges only  
 Zero outlet pressure

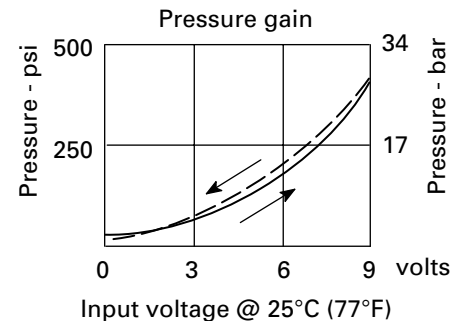
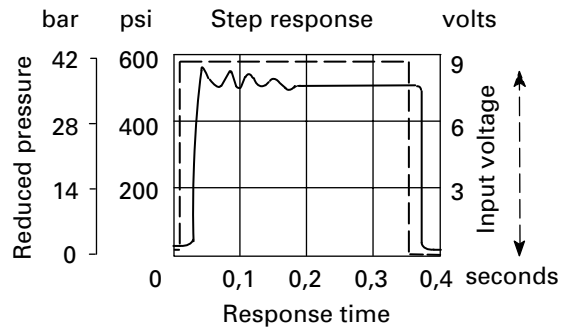

Алматы (7273)495-231  
Ангарск (3955)60-70-56  
Архангельск (8182)63-90-72  
Астрахань (8512)99-46-04  
Барнаул (3852)73-04-60  
Белгород (4722)40-23-64  
Благовещенск (4162)22-76-07  
Брянск (4832)59-03-52  
Владивосток (423)249-28-31  
Владикавказ (8672)28-90-48  
Владимир (4922)49-43-18  
Волгоград (844)278-03-48  
Вологда (8172)26-41-59  
Воронеж (473)204-51-73  
Екатеринбург (343)384-55-89

Иваново (4932)77-34-06  
Ижевск (3412)26-03-58  
Иркутск (395)279-98-46  
Казань (843)206-01-48  
Калининград (4012)72-03-81  
Калуга (4842)92-23-67  
Кемерово (3842)65-04-62  
Киров (8332)68-02-04  
Коломна (4966)23-41-49  
Кострома (4942)77-07-48  
Краснодар (861)203-40-90  
Красноярск (391)204-63-61  
Курск (4712)77-13-04  
Курган (3522)50-90-47  
Липецк (4742)52-20-81

Магнитогорск (3519)55-03-13  
Москва (495)268-04-70  
Мурманск (8152)59-64-93  
Набережные Челны (8552)20-53-41  
Нижний Новгород (831)429-08-12  
Новокузнецк (3843)20-46-81  
Ноябрьск (3496)41-32-12  
Новосибирск (383)227-86-73  
Омск (3812)21-46-40  
Орел (4862)44-53-42  
Оренбург (3532)37-68-04  
Пенза (8412)22-31-16  
Петрозаводск (8142)55-98-37  
Псков (8112)59-10-37  
Пермь (342)205-81-47

Ростов-на-Дону (863)308-18-15  
Рязань (4912)46-61-64  
Самара (846)206-03-16  
Санкт-Петербург (812)309-46-40  
Саратов (845)249-38-78  
Севастополь (8692)22-31-93  
Саранск (8342)22-96-24  
Симферополь (3652)67-13-56  
Смоленск (4812)29-41-54  
Сочи (862)225-72-31  
Ставрополь (8652)20-65-13  
Сургут (3462)77-98-35  
Сыктывкар (8212)25-95-17  
Тамбов (4752)50-40-97  
Тверь (4822)63-31-35

Тольятти (8482)63-91-07  
Томск (3822)98-41-53  
Тула (4872)33-79-87  
Тюмень (3452)66-21-18  
Ульяновск (8422)24-23-59  
Улан-Удэ (3012)59-97-51  
Уфа (347)229-48-12  
Хабаровск (4212)92-98-04  
Чебоксары (8352)28-53-07  
Челябинск (351)202-03-61  
Череповец (8202)49-02-64  
Чита (3022)38-34-83  
Якутск (4112)23-90-97  
Ярославль (4852)69-52-93

Россия +7(495)268-04-70

Казахстан +7(7172)727-132

Киргизия +996(312)96-26-47

<https://vickers.nt-rt.ru> || [vsh@nt-rt.ru](mailto:vsh@nt-rt.ru)