

Алматы (7273)495-231
 Ангарск (3955)60-70-56
 Архангельск (8182)63-90-72
 Астрахань (8512)99-46-04
 Барнаул (3852)73-04-60
 Белгород (4722)40-23-64
 Благовещенск (4162)22-76-07
 Брянск (4832)59-03-52
 Владивосток (423)249-28-31
 Владикавказ (8672)28-90-48
 Владимир (4922)49-43-18
 Волгоград (844)278-03-48
 Вологда (8172)26-41-59
 Воронеж (473)204-51-73
 Екатеринбург (343)384-55-89

Иваново (4932)77-34-06
 Ижевск (3412)26-03-58
 Иркутск (395)279-98-46
 Казань (843)206-01-48
 Калининград (4012)72-03-81
 Калуга (4842)92-23-67
 Кемерово (3842)65-04-62
 Киров (8332)68-02-04
 Коломна (4966)23-41-49
 Кострома (4942)77-07-48
 Краснодар (861)203-40-90
 Красноярск (391)204-63-61
 Курск (4712)77-13-04
 Курган (3522)50-90-47
 Липецк (4742)52-20-81

Магнитогорск (3519)55-03-13
 Москва (495)268-04-70
 Мурманск (8152)59-64-93
 Набережные Челны (8552)20-53-41
 Нижний Новгород (831)429-08-12
 Новокузнецк (3843)20-46-81
 Ноябрьск (3496)41-32-12
 Новосибирск (383)227-86-73
 Омск (3812)21-46-40
 Орел (4862)44-53-42
 Оренбург (3532)37-68-04
 Пенза (8412)22-31-16
 Петрозаводск (8142)55-98-37
 Псков (8112)59-10-37
 Пермь (342)205-81-47

Ростов-на-Дону (863)308-18-15
 Рязань (4912)46-61-64
 Самара (846)206-03-16
 Санкт-Петербург (812)309-46-40
 Саратов (845)249-38-78
 Севастополь (8692)22-31-93
 Саранск (8342)22-96-24
 Симферополь (3652)67-13-56
 Смоленск (4812)29-41-54
 Сочи (862)225-72-31
 Ставрополь (8652)20-65-13
 Сургут (3462)77-98-35
 Сыктывкар (8212)25-95-17
 Тамбов (4752)50-40-97
 Тверь (4822)63-31-35

Тольятти (8482)63-91-07
 Томск (3822)98-41-53
 Тула (4872)33-79-87
 Тюмень (3452)66-21-18
 Ульяновск (8422)24-23-59
 Улан-Удэ (3012)59-97-51
 Уфа (347)229-48-12
 Хабаровск (4212)92-98-04
 Чебоксары (8352)28-53-07
 Челябинск (351)202-03-61
 Череповец (8202)49-02-64
 Чита (3022)38-34-83
 Якутск (4112)23-90-97
 Ярославль (4852)69-52-93

Россия +7(495)268-04-70

Казахстан +7(7172)727-132

Киргизия +996(312)96-26-47

<https://vickers.nt-rt.ru> || vsh@nt-rt.ru



Housings and Miscellaneous Parts

Standard and Special Valve Housings, Orifice Disks, Orifice Sizing Charts, Pilot Pistons, Adapters, Adjustment Kits and Seal Kits



Housings and Miscellaneous Parts

Section contents

	Page
Standard housings	
C-**-2Aluminum (Light duty).....	J-3
C-**-2Aluminum (NFPA fatigue rated).....	J-4
C-**-2Steel (NFPA fatigue rated).....	J-5
C-**-3/3SAluminum (Light duty).....	J-6
C-**-3/3SAluminum (NFPA fatigue rated).....	J-7
C-**-3Steel (NFPA fatigue rated).....	J-8
C-**-3SSteel (NFPA fatigue rated).....	J-9
C-16-3SSteel (NFPA fatigue rated) special housings for EPV16 only.....	J-10
C-**-4Aluminum (Light duty).....	J-11
C-**-4Aluminum (NFPA fatigue rated).....	J-12
C-**-4Steel (NFPA fatigue rated).....	J-13
C-**-5SSteel and aluminum (NFPA fatigue rated) (special housings for PFRD/S only).....	J-14
Port dimensions - all housings.....	J-15
Special Housings - Load control valves	
Part numbers - CBV, POC, VCB housings.....	J-15
Dimensions - 10 size CBV, POC housings.....	J-18
Dimensions - 12 size CBV, POC housings.....	J-21
Dimensions - 10 size VCB housings.....	J-25
Dimensions - 12 size VCB housings.....	J-27
Special Housings - Bolt on manifold for Eaton spool and disk motors	
Overview.....	J-29
Dual CBV package with brake release shuttle for H & T series Eaton motors.....	J-30
Dual POC package with brake release shuttle for H & T series Eaton motors.....	J-31
Cross over relief valve package for H & T series Eaton motors.....	J-32
Cross over relief valve package for 2000 series Eaton motors.....	J-33
Dual CBV package with brake release shuttle for 2000 series Eaton motors.....	J-34
Dual POC package with brake release shuttle for 2000 series Eaton motors.....	J-35
Cavity plugs	
Standard cavity plugs.....	J-36
Special cavity plugs.....	J-37
Orifice discs and orifice sizing chart	
Orifice discs.....	J-38
Orifice sizing chart (Metric).....	J-39
Orifice sizing chart (US units).....	J-40
Miscellaneous parts	
Pilot pistons.....	J-41
Sense check kits and panel mount adapters.....	J-42
Miscellaneous parts / adjustment kits.....	J-43
Adjustment kits.....	J-43
Seal kits.....	J-45

C-**-2

Aluminum housings
(Light duty)

HOUSING	PORTS 1 & 2	PART NUMBER	CODE
C-10-2	3/8" BSPP SAE 6	02-175462 566151	(A)3B (A)6T
C-16-2	3/4" BSPP SAE 12	02-175463 566149	(A)6B (A)12T
C-20-2	1" BSPP SAE 16	02-175464 566409	(A)8B (A)16T

Notes

BSPP porting is designated by "B" in the model code
SAE porting is designated by "T" in the model code.

Light duty aluminum housings are intended for applications up to 210 bar (3000 psi) with light to moderate duty cycles.

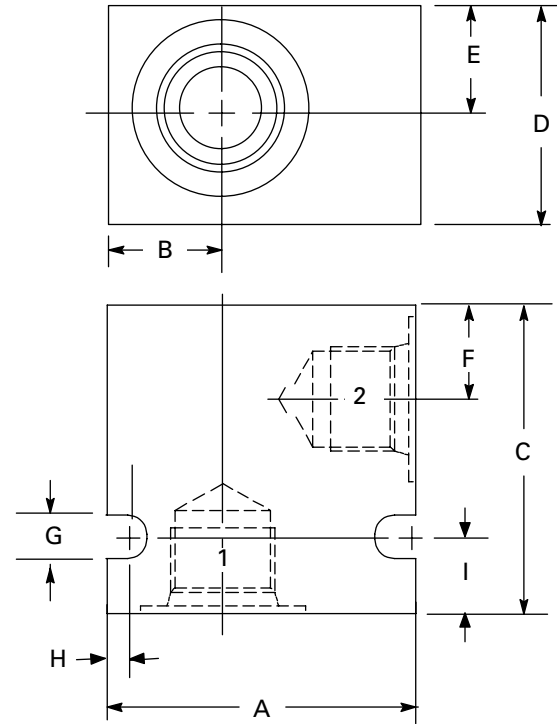

DIMENSIONS	A	B	C	D	E	F	G	H	I	MASS
mm (inch)										kg (lb)
C-10-2	50,8 (2.00)	19,0 (0.75)	50,8 (2.00)	31,7 (1.25)	15,9 (0.62)	19,0 (0.75)	7,1 (0.28)	3,1 (0.12)	12,7 (0.50)	0,1 (0.35)
C-16-2	76,2 (3.0)	28,5 (1.12)	76,2 (3.00)	47,6 (1.87)	23,8 (0.94)	25,4 (1.00)	8,6 (0.34)	4,0 (0.16)	19,0 (0.75)	0,5 (1.21)
C-20-2	88,9 (3.5)	34,3 (1.35)	88,9 (3.50)	68,5 (2.70)	34,3 (1.35)	36,8 (1.45)	8,6 (0.34)	4,0 (0.16)	21,6 (0.85)	0,8 (1.90)

J

C-**-2

Aluminum housings
(NFPA fatigue rated)

HOUSING	PORTS 1 & 2	PART NUMBER	CODE
C-8-2	1/4" BSPP	02-160727	(A)2G
	3/8" BSPP	02-160728	(A)3G
	SAE 4	02-160730	(A)4H
	SAE 6	02-160731	(A)6H
	SAE 8	02-160732	(A)8H
C-10-2	1/4" BSPP	876702	(A)2G
	3/8" BSPP	876703	(A)3G
	SAE 6	876700	(A)6H
	SAE 8	876701	(A)8H
C-12-2	1/2" BSPP	02-161118	(A)4G
	3/4" BSPP	02-161117	(A)6G
	SAE 10	02-160640	(A)10H
	SAE 12	02-160644	(A)12H

HOUSING	PORTS 1 & 2	PART NUMBER	CODE
C-12-2U	1/2" BSPP	02-161116	(A)4G
	3/4" BSPP	02-161115	(A)6G
	SAE 10	02-160641	(A)10H
	SAE 12	02-160645	(A)12H
C-16-2	1/2" BSPP	876716	(A)4G
	3/4" BSPP	876718	(A)6G
	SAE 10	876717	(A)10H
	SAE 12	566113	(A)12H
C-20-2	3/4" BSPP	876732	(A)6G
	1" BSPP	876734	(A)8G
	SAE 12	876733	(A)12H
	SAE 16	876735	(A)16H

Notes

BSPP porting is designated by "G" in the model code
SAE porting is designated by either "H" or "T" in the model code.

Fatigue rated aluminum housings are intended for applications up to 210 bar (3000 psi) with harsh duty cycles. These housings have been fatigue rated to NFPA standards to one million cycles.

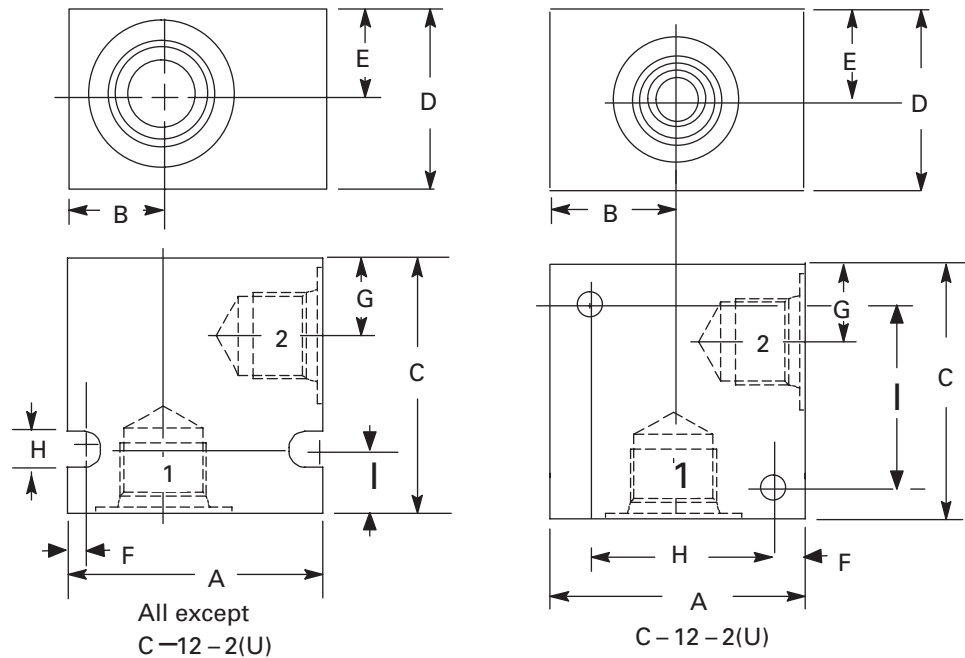

DIMENSIONS	A	B	C	D	E	F	G	H	I	MASS
										kg (lb)
mm (inch)										
C-8-2	50,8 (2.00)	19,0 (0.75)	51,0 (2.00)	38,1 (1.50)	19,0 (0.75)	3,4 (0.13)	15,5 (0.61)	7,1 (0.28)	12,7 (0.50)	0,2 (0.46)
C-10-2	63,5 (2.50)	25,4 (1.00)	63,5 (2.50)	50,8 (2.00)	25,4 (1.00)	9,5 (0.37)	20,8 (0.81)	7,1 (0.28)	19,0 (0.75)	0,4 (1.00)
C-12-2(U)	88,9 (3.50)	44,5 (1.75)	88,9 (3.50)	50,8 (2.00)	25,4 (1.00)	12,7 (0.50)	28,7 (1.13)	63,5 (2.50)	63,5 (2.50)	0,8 (1.96)
C-16-2	88,9 (3.50)	34,9 (1.37)	88,9 (3.50)	63,5 (2.50)	31,7 (1.25)	10,3 (0.40)	28,4 (1.11)	8,7 (0.34)	25,4 (1.00)	1,2 (2.75)
C-20-2	101,6 (4.00)	38,1 (1.50)	101,6 (4.00)	82,5 (3.25)	41,3 (1.62)	10,3 (0.40)	36,0 (1.41)	8,7 (0.34)	25,4 (1.00)	1,8 (4.00)

C-**-2

Steel housings
(NFPA fatigue rated)

HOUSING	PORTS 1 & 2	PART NUMBER	CODE
C-8-2	1/4" BSPP	02-160733	(S)2G
	3/8" BSPP	02-160734	(S)3G
	SAE 4	02-160736	(S)4T
	SAE 6	02-160737	(S)6T
	SAE 8	02-160738	(S)8T
C-10-2	1/4" BSPP	02-175102	(S)2G
	3/8" BSPP	02-175103	(S)3G
	SAE 6	02-175100	(S)6T
	SAE 8	02-175101	(S)8T
C-12-2	1/2" BSPP	02-172062	(S)4G
	3/4" BSPP	02-169665	(S)6G
	SAE 10	02-169744	(S)10T
	SAE 12	02-169782	(S)12T

HOUSING	PORTS 1 & 2	PART NUMBER	CODE
C-12-2U	1/2" BSPP	02-172512	(S)4G
	3/4" BSPP	02-162922	(S)6G
	SAE 10	02-169817	(S)10T
	SAE 12	02-169790	(S)12T
C-16-2	1/2" BSPP	02-175106	(S)4G
	3/4" BSPP	02-175107	(S)6G
	SAE 10	02-175104	(S)10T
	SAE 12	02-175105	(S)12T
C-20-2	3/4" BSPP	02-175110	(S)6G
	1" BSPP	02-175111	(S)8G
	SAE 12	02-175108	(S)12T
	SAE 16	02-175109	(S)16T

Notes

BSPP porting is designated by "G" in the model code
SAE porting is designated by "T" in the model code.

Fatigue rated steel housings are intended for applications up to 350 bar (5000 psi) with harsh duty cycles. These housings have been fatigue rated to NFPA standards to one million cycles.

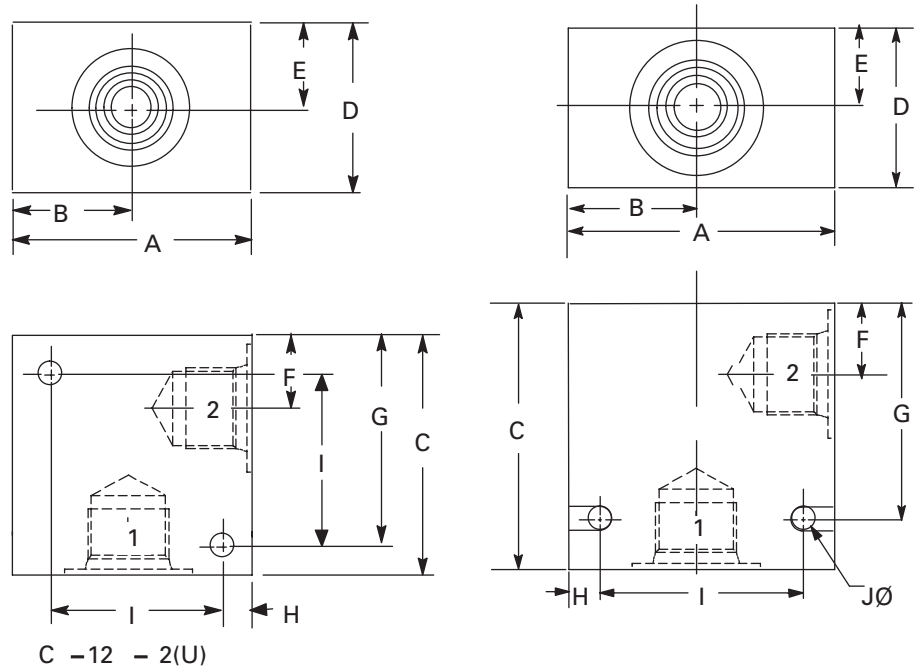

DIMENSIONS	A	B	C	D	E	F	G	H	I	J	MASS
mm (inch)											kg (lb)
C-8-2*	50,8 (2.00)	19,0 (0.75)	50,8 (2.00)	38,1 (1.50)	19,0 (0.75)	15,5 (0.61)	38,1 (1.50)	3,3 (0.13)	43,9 (1.73)	7,1 (0.28)	0,5 (1.19)
C-10-2	63,5 (2.50)	25,4 (1.00)	63,5 (2.50)	44,4 (1.75)	22,2 (0.87)	19,0 (0.75)	50,8 (2.00)	9,5 (0.37)	44,4 (1.75)	7,1 (0.28)	0,3 (0.83)
C-12-2(U)	88,9 (3.50)	28,5 (1.12)	88,9 (3.50)	50,8 (2.00)	25,4 (1.00)	28,7 (1.13)	76,2 (3.00)	12,7 (0.50)	63,5 (2.50)	10,3 (0.40)	1,9 (4.28)
C-16-2	88,9 (3.50)	38,1 (1.750)	76,2 (3.00)	50,8 (2.00)	25,4 (1.00)	25,4 (1.00)	63,5 (2.50)	12,7 (0.50)	63,5 (2.50)	10,3 (0.40)	2,2 (5.00)
C-20-2	101,6 (4.00)	41,2 (1.62)	88,9 (3.50)	63,5 (2.50)	31,7 (1.25)	31,7 (1.25)	76,2 (3.00)	12,7 (0.50)	76,2 (3.00)	10,3 (0.40)	3,6 (7.96)

* 8 series housing utilize a slot instead of a mounting hole.

C-**-3/3S

Aluminum housings
(Light duty)

HOUSING	PORTS 1, 2 & 3	PART NUMBER	CODE
C-10-3	3/8" BSPP SAE 6	02-173358 566162	(A)3B (A)6T
C-10-3S	3/8" BSPP SAE 6	02-175470 566413	(A)3B (A)6T
C-16-3	3/4" BSPP SAE 12	02-175465 566152	(A)6B (A)12T
C-16-3S	3/4" BSPP SAE 12	02-175471 566414	(A)6B (A)12T
C-20-3	1" BSPP SAE 12	02-175466 566408	(A)8B (A)12T
C-20-3S	1" BSPP SAE 16	02-175472 566415	(A)8B (A)16T

Notes

BSPP porting is designated by "B" in the model code
SAE porting is designated by "T" in the model code.

Light duty aluminum housings are intended for applications up to 210 bar (3000 psi) with light to moderate duty cycles.

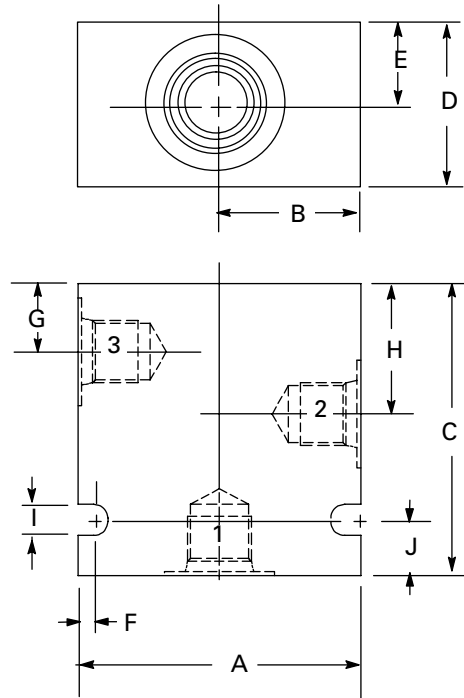

DIMENSIONS	A	B	C	D	E	F	G	H	I	J	MASS
mm (inch)											kg (lb)
C-10-3	63,5 (2.50)	31,7 (1.25)	66,6 (2.62)	31,7 (1.25)	15,8 (0.62)	3,1 (0.12)	19,0 (0.75)	34,9 (1.37)	7,1 (0.28)	12,7 (0.50)	0,3 (0.64)
C-10-3S	63,5 (2.50)	34,9 (1.37)	69,8 (2.75)	38,1 (1.50)	19,1 (0.75)	3,1 (0.12)	12,7 (0.50)	31,7 (1.25)	7,1 (0.28)	12,7 (0.50)	0,2 (0.51)
C-16-3	101,6 (4.00)	50,8 (2.00)	107,9 (4.25)	50,8 (2.00)	25,4 (1.00)	4,0 (0.16)	25,4 (1.00)	53,9 (2.12)	8,6 (0.33)	25,4 (1.00)	1,0 (2.3)
C-16-3S	88,9 (3.50)	47,6 (1.87)	88,9 (3.50)	60,3 (2.37)	30,1 (1.63)	4,0 (0.16)	17,4 (0.68)	38,1 (1.50)	8,7 (0.34)	19,0 (0.75)	0,7 (1.66)
C-20-3	114,3 (4.50)	57,1 (2.25)	139,7 (5.50)	63,5 (2.50)	31,7 (1.25)	4,0 (0.16)	31,7 (1.25)	72,1 (2.84)	10,4 (0.41)	25,4 (1.00)	1,7 (3.92)
C-20-3S	101,6	57,1	107,9	69,8	34,9	4,0	20,6	50,8	8,7	19,0	1,2

C-**-3/3S

Aluminum housings
(NFPA fatigue rated)

HOUSING	PORTS 1, 2 & 3	PART NUMBER	CODE
C-8-3	1/4" BSPP	02-160739	(A)2G
	3/8" BSPP	02-160740	(A)3G
	SAE 4	02-160741	(A)4H
	SAE 6	02-160742	(A)6H
C-10-3	1/4" BSPP	876705	(A)2G
	3/8" BSPP	876714	(A)3G
	SAE 6	876704	(A)6H
	SAE 8	876711	(A)8H
C-10-3S	1/4" BSPP	876707	(A)2G
	3/8" BSPP***	876710	(A)3G
	SAE 6	876706	(A)6H
	SAE 8**	876712	(A)8H
C-12-3	3/8" BSPP	02-161816	(A)3G
	1/2" BSPP	02-161817	(A)4G
	SAE 10	02-160642	(A)10H
	SAE 12	02-160646	(A)12H
C-12-3S	1/2" BSPP*	02-178270	(A)4G
	3/4" BSPP*	02-178271	(A)6G
	SAE 10**	02-178268	(A)10H
	SAE 12**	02-178269	(A)12H

HOUSING	PORTS 1, 2 & 3	PART NUMBER	CODE
C-16-3	1/2" BSPP	876720	(A)4G
	3/4" BSPP	876722	(A)6G
	SAE 10	876721	(A)10H
	SAE 12	876723	(A)12H
C-16-3S	1/2" BSPP	02-160676	(A)4G
	3/4" BSPP	876726	(A)6G
	SAE 10	876725	(A)10H
	SAE 12	876727	(A)12H
C-20-3	1/2" BSPP	876737	(A)4G
	3/4" BSPP***	876738	(A)6G
	SAE 10	876757	(A)10H
	SAE 12	876739	(A)12H
C-20-3S	3/4" BSPP	876740	(A)6G
	1" BSPP	876742	(A)8G
	SAE 12	876741	(A)12H
	SAE 16	876743	(A)16H

* Port 3 = 3/8" BSPP
 ** Port 3 = SAE 6
 *** Port 3 = 1/4" BSPP

Notes

BSPP porting is designated by "G" in the model code
 SAE porting is designated by either "H" or "T" in the model code.

Fatigue rated aluminum housings are intended for applications up to 210 bar (3000 psi) with harsh duty cycles. These housings have been fatigue rated to NFPA standards to one million cycles.

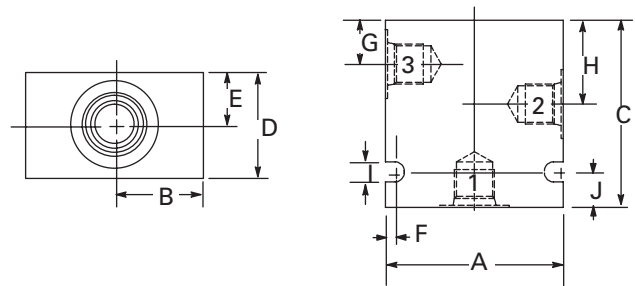

DIMENSIONS	A	B	C	D	E	F	G	H	I	J	MASS
mm (inch)											kg (lb)
C-8-3	63,5 (2.50)	31,8 (1.25)	66,6 (2.62)	38,1 (1.50)	19,0 (0.75)	3,4 (0.13)	15,5 (0.61)	29,8 (1.17)	7,1 (0.28)	13,0 (0.51)	0,4 (0.83)
C-10-3	76,2 (3.00)	38,1 (1.50)	76,2 (3.00)	50,8 (2.00)	25,4 (1.00)	9,5 (0.37)	20,8 (0.81)	36,6 (1.44)	7,1 (0.28)	19,0 (0.75)	0,7 (1.65)
C-10-3S	76,2 (3.00)	38,1 (1.50)	76,2 (3.00)	50,8 (2.00)	25,4 (1.00)	9,5 (0.37)	16,8 (0.66)	33,5 (1.32)	7,1 (0.28)	19,0 (0.75)	0,7 (1.65)
C-12-3	88,9 (3.50)	44,5 (1.75)	107,9 (4.25)	50,8 (2.00)	25,4 (1.00)	12,7 (0.50)	28,7 (1.13)	51,6 (2.03)	10,3 (0.41)	12,7 (0.50)	0,8 (1.80)
C-12-3S	88,9 (3.50)	44,5 (1.75)	101,6 (4.00)	50,8 (2.00)	25,4 (1.00)	12,7 (0.50)	23,0 (0.91)	42,1 (1.66)	10,3 (0.41)	12,7 (0.50)	0,8 (1.80)
C-16-3	114,3 (4.50)	60,3 (2.37)	114,3 (4.50)	63,5 (2.50)	31,7 (1.25)	10,3 (0.40)	28,4 (1.12)	57,0 (2.24)	8,7 (0.34)	25,4 (1.00)	2,0 (4.50)
C-16-3S	114,3 (4.50)	60,3 (2.37)	114,3 (4.50)	63,5 (2.50)	31,7 (1.25)	10,3 (0.40)	20,4 (0.80)	41,1 (1.62)	8,7 (0.34)	25,4 (1.00)	2,0 (4.40)
C-20-3	127,0 (5.00)	63,5 (2.50)	139,7 (5.50)	82,5 (3.25)	41,2 (1.62)	10,3 (0.40)	36,0 (1.42)	76,5 (3.01)	8,7 (0.34)	25,4 (1.00)	3,5 (7.71)
C-20-3S	127,0 (5.00)	63,5 (2.50)	127,0 (5.00)	82,5 (3.25)	41,2 (1.62)	10,3 (0.40)	24,9 (0.98)	55,0 (2.17)	8,7 (0.34)	25,4 (1.00)	3,6 (8.00)

C-**-3

Steel housings
(NFPA fatigue rated)

HOUSING	PORTS 1, 2 & 3	PART NUMBER	CODE
C-8-3	1/4" BSPP	02-160745	(S)2G
	3/8" BSPP	02-160746	(S)3G
	SAE 4	02-160743	(S)4T
	SAE 6	02-160744	(S)6T
C-10-3	1/4" BSPP	02-175127	(S)2G
	3/8" BSPP	02-175128	(S)3G
	SAE 6	02-175124	(S)6T
	SAE 8	02-175125	(S)8T
C-12-3	1/2" BSPP	02-169815	(S)2G
	3/8" BSPP	02-169814	(S)3G
	SAE 10	02-161070	(S)10T
	SAE 12	02-169816	(S)12T
C-16-3	1/2" BSPP	02-175131	(S)4G
	3/4" BSPP	02-175132	(S)6G
	SAE 10	02-175129	(S)10T
	SAE 12	02-175130	(S)12T
C-20-3	3/4" BSPP	02-175135	(S)6G
	1" BSPP	02-175136	(S)8G
	SAE 12	02-175133	(S)12T
	SAE 16	02-175134	(S)16T

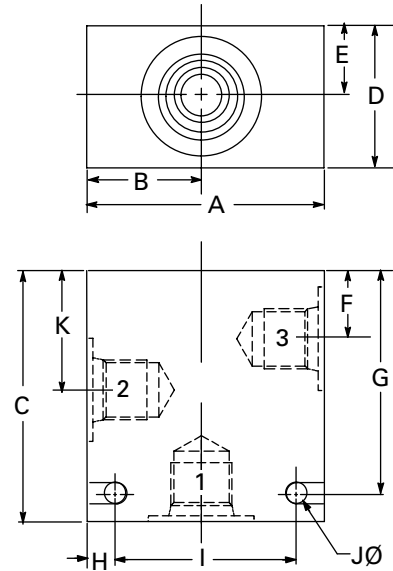

Notes

BSPP porting is designated by "B" in the model code
SAE porting is designated by "T" in the model code.

Fatigue rated steel housings are intended for applications up to 350 bar (5000 psi) with harsh duty cycles. These housings have been fatigue rated to NFPA standards to one million cycles.

DIMENSIONS	A	B	C	D	E	F	G	H	I	J	K	MASS
mm (inch)												kg (lb)
C-8-3*	63,5 (2.50)	31,8 (1.25)	66,0 (2.75)	38,1 (1.50)	19,0 (0.75)	15,5 (0.61)	53,0 (2.12)	3,3 (0.13)	56,6 (2.23)	7,1 (0.28)	29,8 (1.17)	0,9 (2.15)
C-10-3	76,2 (3.00)	38,1 (1.50)	76,2 (3.00)	44,4 (1.75)	22,2 (0.87)	19,0 (0.75)	63,5 (2.50)	9,5 (0.37)	57,1 (2.25)	7,1 (0.28)	34,9 (1.37)	1,7 (3.75)
C-12-3	88,9 (3.50)	44,4 (1.75)	101,6 (4.00)	50,8 (2.00)	25,4 (1.00)	28,7 (1.13)	88,9 (3.50)	12,7 (0.50)	63,5 (2.50)	10,3 (0.40)	51,5 (2.03)	3,0 (6.75)
C-16-3	101,6 (4.00)	50,8 (2.00)	107,9 (4.25)	50,9 (2.00)	25,4 (1.00)	25,4 (1.00)	88,9 (3.50)	12,7 (0.50)	76,2 (3.00)	10,3 (0.40)	53,9 (2.12)	3,4 (7.70)
C-20-3	114,3 (4.50)	57,1 (2.25)	139,7 (5.50)	63,5 (2.50)	31,7 (1.25)	31,7 (1.25)	114,3 (4.50)	19,0 (0.75)	76,2 (3.00)	11,9 (0.47)	72,2 (2.84)	6,4 (14.30)

* 8 Series housings utilize a slot instead of mounting holes.

C-**-3S

Steel housings
(NFPA fatigue rated)

HOUSING	PORTS 1 & 2	PORT 3	PART NUMBER	CODE
C-10-3S	3/8" BSPP	1/4" BSPP	02-163313	(S)3G
	1/2" BSPP	1/4" BSPP	02-163324	(S)4G
	SAE 6	SAE 6	02-171961	(S)6T
	SAE 8	SAE 6	02-163322	(S)8T
	SAE 10	SAE 6	02-163323	(S)10T
C-12-3S	1/2" BSPP	3/8" BSPP	02-160994	(S)4G
	3/4" BSPP	3/8" BSPP	02-160995	(S)6G
	SAE 10	SAE 6	02-160996	(S)10T
	SAE 12	SAE 6	02-160997	(S)12T
C-16-3S	1/2" BSPP	3/8" BSPP	02-175118	(S)6G
	3/4" BSPP	3/8" BSPP	02-175119	(S)6G
	SAE 10	SAE 6	02-175116	(S)10T
	SAE 12	SAE 6	02-175117	(S)12T
C-20-3S	3/4" BSPP	3/8" BSPP	02-175122	(S)6G
	1" BSPP	3/8" BSPP	02-175123	(S)8G
	SAE 12	SAE 6	02-175120	(S)12T
	SAE 16	SAE 6	02-175121	(S)16T

Notes

BSPP porting is designated by "G" in the model code
SAE porting is designated by "T" in the model code.

Fatigue rated steel housings are intended for applications up to 350 bar (5000 psi) with harsh duty cycles. These housings have been fatigue rated to NFPA standards to one million cycles.

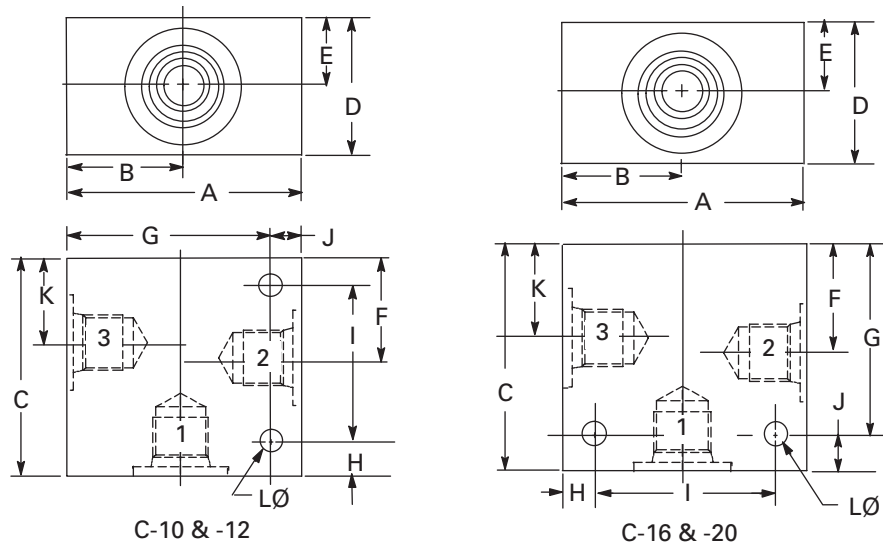

DIMENSIONS	A	B	C	D	E	F	G	H	I	J	K	LØ	MASS
mm (inch)													kg (lb)
C-10-3S	63,5 (2.50)	31,8 (1.25)	76,2 (3.00)	41,3 (1.63)	20,7 (0.82)	36,6 (1.44)	53,8 (2.12)	11,2 (0.44)	53,8 (2.12)	9,7 (0.38)	19,8 (0.78)	8,7 (0.34)	1,08 (2.40)
C-12-3S	88,9 (3.50)	44,5 (1.75)	101,6 (4.00)	50,8 (2.00)	25,4 (1.00)	41,9 (1.65)	76,2 (3.00)	31,7 (1.25)	57,1 (2.25)	12,7 (0.50)	23,1 (0.91)	10,3 (0.40)	2,4 (5.40)
C-16-3S	88,9 (3.50)	41,2 (1.62)	88,9 (3.50)	50,8 (2.00)	25,4 (1.00)	38,1 (1.50)	69,8 (2.75)	12,7 (0.50)	63,5 (2.50)	19,0 (0.75)	17,4 (0.68)	10,3 (0.40)	2,6 (5.90)
C-20-3S	101,6 (4.00)	44,4 (1.75)	114,3 (4.50)	63,5 (2.50)	31,7 (1.25)	50,8 (2.00)	88,9 (3.50)	12,7 (0.50)	76,2 (3.00)	25,4 (1.00)	20,6 (0.81)	10,3 (0.40)	4,6 (10.24)

C-16-3S

Steel (NFPA fatigue rated)

Special housings for EPV16 only

For use with EPV16-A or B only

HOUSING NUMBER

CODE	PORT SIZE	ALUMINUM		STEEL	
		EPV16-A	EPV16-B	EPV16-A	EPV16-B
4G	1/2" BSPP	02-185448	02-166607	02-180050	02-165500
6G	3/4" BSPP	02-185449	02-161582	02-180051	02-164931
10H	SAE 10	02-185446	02-170238	–	–
12H	SAE 12	02-185447	02-166609	–	–
10T	SAE 10	–	–	02-180048	02-161983
12T	SAE 12	–	–	02-180049	02-161982
5C	CETOP5 (NFPA D05) interface (Requires steel housing)				

MODEL	A	B	C	D	E	F	G	ØH	J	MASS kg (lb)	
										Alum	Steel
Modified C-16-3S body	76,2 (3.00)	30,2 (1.19)	79,2 (3.12)	100,8 (3.97)	38,1 (1.50)	12,7 (0.50)	21,6 (0.85)	8,7 (0.34)	60,4 (2.38)	2,0 (4.50)	6,0 (13.5)

Modified housing for use with EPV16-A.

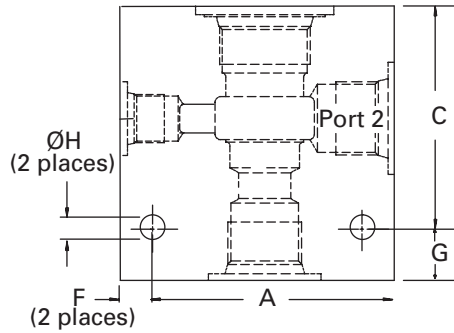

Modified housing for use with EPV16-B.

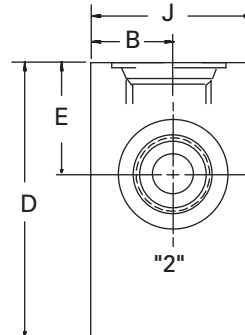
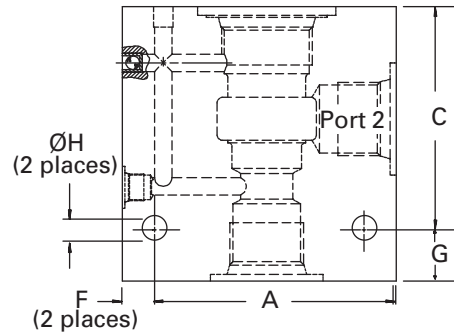

C-**-4

Aluminum housings
(Light duty)

HOUSING	PORTS 1, 2, 3 & 4	PART NUMBER	CODE
C-10-4	3/8" BSPP SAE 6	02-179705 566161	(A)3B (A)6T
C-16-4	3/4" BSPP SAE 12	02-175468 566411	(A)6B (A)12T
C-20-4	1" BSPP SAE 16	02-175469 566412	(A)8B (A)16T

HOUSING (FDC**-**ONLY)

C-10-4	3/8" BSPP SAE 6	02-175467 566234	(A)3B (A)6T
C-16-4	3/4" BSPP SAE 12	02-175468 566200	(A)6B (A)12T

Notes

BSPP porting is designated by "B" in the model code
SAE porting is designated by "T" in the model code.

Light duty aluminum housings are intended for applications up to 210 bar (3000 psi) with light to moderate duty cycles.

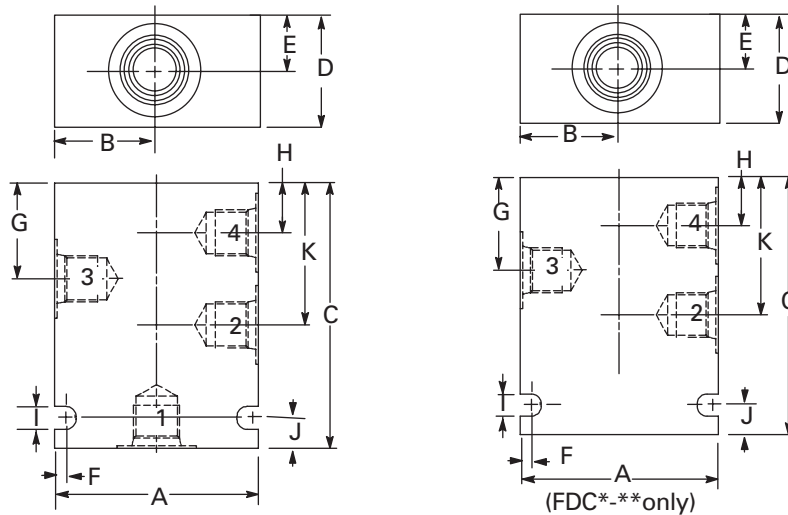

DIMENSIONS	A	B	C	D	E	F	G	H	I	J	K	MASS
mm (inch)												kg (lb)
C-10-4	63,5 (2.50)	31,7 (1.25)	82,5 (3.25)	31,7 (1.25)	15,8 (0.62)	3,1 (0.12)	34,9 (1.37)	19,0 (0.75)	7,1 (0.28)	9,5 (0.37)	50,8 (2.00)	0,3 (0.72)
C-16-4	106,6 (4.00)	50,8 (2.00)	133,3 (5.25)	50,8 (2.00)	25,4 (1.00)	3,8 (0.15)	53,9 (2.12)	25,4 (1.00)	8,7 (0.34)	22,2 (0.87)	82,5 (3.25)	1,4 (3.24)
C-20-4	114,3 (4.50)	57,1 (2.25)	117,8 (7.00)	63,5 (2.50)	31,7 (1.25)	4,0 (0.16)	72,1 (2.84)	31,7 (1.25)	10,4 (0.41)	25,4 (1.00)	113,5 (4.47)	2,6 (5.76)

Note

For C-10-4 housings for VCB valves see page J-25.

C-**-4

Aluminum housings
(NFPA fatigue rated)

HOUSING	PORTS 1, 2, 3 & 4	PART NUMBER	CODE
C-8-4	1/4" BSPP	02-160747	(A)2G
	3/8" BSPP	02-160748	(A)3G
	SAE 6	02-160749	(A)6H
	SAE 8	02-160750	(A)8H
C-10-4	1/4" BSPP	876709	(A)2G
	3/8" BSPP	876715	(A)3G
	SAE 6	876708	(A)6H
C-16-4	1/2" BSPP	876728	(A)4G
	3/4" BSPP	876730	(A)6G
	SAE 10	876279	(A)10H
C-20-4	SAE 12	876731	(A)12H
	3/4" BSPP	876744	(A)6G
	1" BSPP	876746	(A)8G
	SAE 12	876745	(A)12H
	SAE 16	876747	(A)16H

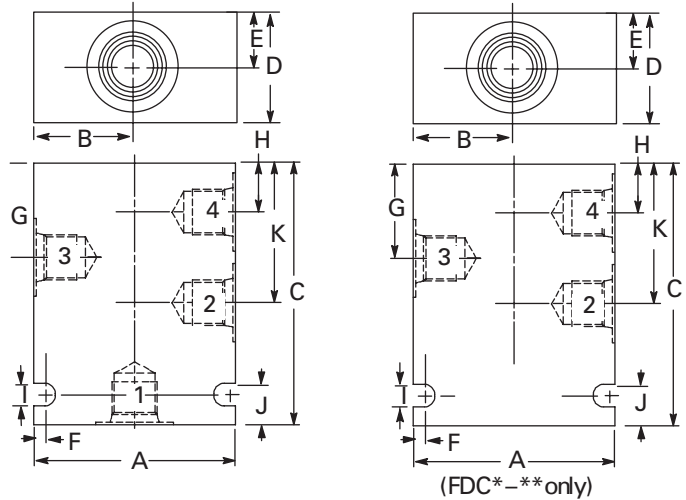

HOUSING (FDC*-**-ONLY)

C-10-4	1/4" BSPP	02-185804	(A)2G
	3/8" BSPP	02-185805	(A)3G
	SAE 6	02-185802	(A)6H
	SAE 8	02-185803	(A)8H

Notes

BSPP porting is designated by "G" in the model code
SAE porting is designated by either "H" in the model code.

Fatigue rated aluminum housings are intended for applications up to 210 bar (3000 psi) with harsh duty cycles. These housings have been fatigue rated to NFPA standards to one million cycles.

For C-10-4 and C-12-4 housings for VCB valves see pages J-25 & J-27 respectively.

DIMENSIONS	A	B	C	D	E	F	G	H	I	J	K	MASS
mm (inch)												kg (lb)
C-10-4	76,2 (3.00)	38,1 (1.50)	88,9 (3.50)	50,8 (2.00)	25,4 (1.00)	9,5 (0.37)	36,6 (1.44)	20,8 (0.82)	7,1 (0.28)	12,7 (0.50)	52,5 (2.07)	0,9 (2.00)
C-16-4	114,3 (4.50)	60,3 (2.37)	139,7 (5.50)	63,5 (2.50)	31,7 (1.25)	10,3 (0.40)	57,0 (2.24)	28,4 (1.12)	8,7 (0.34)	25,4 (1.00)	85,5 (3.37)	2,4 (5.29)
C-20-4	127,0 (5.00)	63,5 (2.50)	177,8 (7.00)	82,5 (3.25)	41,2 (1.62)	10,3 (0.40)	76,5 (3.01)	36,0 (1.42)	8,7 (0.34)	19,0 (0.75)	117,8 (4.63)	4,7 (10.5)

C-**-4

Steel housings
(NFPA fatigue rated)

HOUSING	PORTS 1, 2, 3 & 4	PART NUMBER	CODE
C-8-4	1/4" BSPP	02-160753	(S)2G
	3/8" BSPP	02-160754	(S)3G
	SAE 4	02-160751	(S)4T
	SAE 6	02-160752	(S)6T
C-10-4	1/4" BSPP	02-175139	(S)2G
	3/8" BSPP	02-175140	(S)3G
	SAE 6	02-175137	(S)6T
	SAE 8	02-175138	(S)8T
C-16-4	1/2" BSPP	02-175143	(S)4G
	3/4" BSPP	02-175144	(S)6G
	SAE 10	02-175141	(S)10T
	SAE 12	02-175142	(S)12T
C-20-4	1/2" BSPP	02-175147	(S)4G
	3/4" BSPP	02-175148	(S)6G
	SAE 12	02-175145	(S)12T
	SAE 16	02-175146	(S)16T

Notes

BSPP porting is designated by "G" in the model code
SAE porting is designated by "T" in the model code
8 series utilize slot in place of mounting hole.

Fatigue rated steel housings are intended for applications up to 350 bar (5000 psi) with harsh duty cycles. These housings have been fatigue rated to NFPA standards to one million cycles.

For C-10-4 and C-12-4 housings for VCB valves see pages J-24 & J-27 respectively.

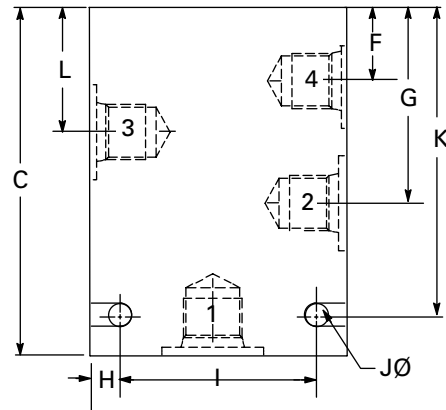
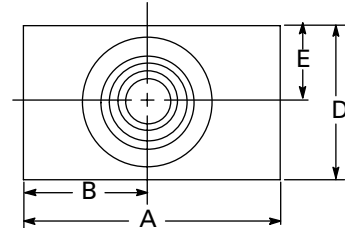

DIMENSIONS	A	B	C	D	E	F	G	H	I	J	K	L	MASS
mm (inch)													kg (lb)
C-8-4*	63,5 (2.50)	31,8 (1.25)	82,6 (3.25)	38,1 (1.50)	19,0 (0.75)	15,5 (0.61)	44,1 (1.74)	3,3 (0.13)	57,1 (2.25)	7,1 (0.28)	73,0 (2.88)	29,8 (1.17)	1,2 (2.70)
C-10-4	76,2 (3.00)	38,1 (1.50)	88,9 (3.50)	44,4 (1.75)	22,2 (0.87)	19,0 (0.75)	50,8 (2.00)	9,5 (0.37)	57,1 (2.25)	7,1 (0.28)	76,2 (3.00)	34,9 (1.37)	1,9 (4.35)
C-16-4	101,6 (4.00)	50,8 (2.00)	139,7 (5.50)	50,8 (2.00)	25,4 (1.00)	25,4 (1.00)	82,5 (3.25)	12,7 (0.50)	76,2 (3.00)	10,3 (0.40)	120,6 (4.75)	53,9 (2.12)	5,6 (12.40)
C-20-4	114,3 (4.50)	57,1 (2.25)	177,8 (7.00)	63,5 (2.50)	31,7 (1.25)	31,7 (1.25)	113,5 (4.47)	19,0 (0.75)	76,2 (3.00)	11,8 (0.47)	152,4 (6.00)	72,1 (2.84)	8,2 (18.20)

* 8 Series housings utilize slot instead of mounting holes.



C-**-5S

Steel and aluminum housings
(NFPA fatigue rated)

Special housings for PFRD/S only

HOUSING	PORTS 2,3,4	PORT 5	ALUMINUM PART NUMBER	CODE	STEEL PART NUMBER	CODE
C-12-5S	SAE 10	SAE 4	4993511-001	(A)10T	4994808-001	(S)10T
	SAE 12	SAE 4	4993511-002	(A)12T	4994808-002	(S)12T
	1/2" BSPP	1/4" BSPP	4993511-003	(A)04G	4994808-003	(S)04G
	3/4" BSPP	1/4" BSPP	4993511-004	(A)06G	4994808-004	(S)06G
C-16-5S	SAE 12	SAE 4	4993512-001	(A)12T	4994809-001	(S)12T
	SAE 16	SAE 4	4993512-002	(A)16T	4994809-002	(S)16T
	3/4" BSPP	1/4" BSPP	4993512-003	(A)06G	4994809-003	(S)06G
	1" BSPP	1/4" BSPP	4993512-004	(A)08G	4994809-004	(S)08G
C-20-5S	SAE 12	SAE 4	4993513-001	(A)12T	4994810-001	(S)12T
	SAE 16	SAE 4	4993513-002	(A)16T	4994810-002	(S)16T
	3/4" BSPP	1/4" BSPP	4993513-003	(A)06G	4994810-003	(S)06G
	1" BSPP	1/4" BSPP	4993513-004	(A)08G	4994810-004	(S)08G

Notes

BSPP porting is designated by "G" in the model code
SAE porting is designated by "T" in the model code.

Fatigue rated aluminum and steel housings are intended for applications up to 210 bar (3000 psi) and 350 bar (5000 psi) respectively with harsh duty cycles. These housings have been fatigue rated to NFPA standards to one million cycles.

Note

Port 1 unused, blind cavity is machined into this housing.

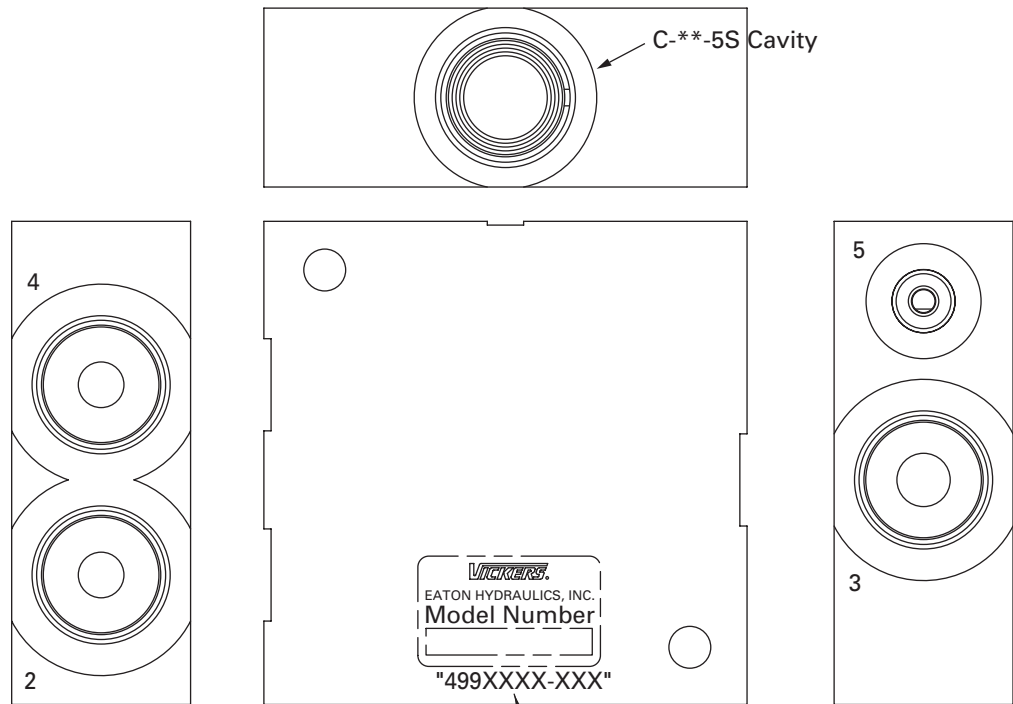

This number will depend on which manifold is ordered

DIMENSIONS	A	B	C	D	E	F	G	H	I	J	K	L	M	DIAM. N
mm (inch)														
C-12-5S	100,8 (3.97)	50,4 (1.99)	96,3 (3.79)	37,3 (1.47)	18,7 (0.74)	16,7 (0.66)	54,0 (2.13)	34,1 (1.34)	73,8 (2.91)	10,2 (0.40)	88,9 (3.50)	12,7 (0.50)	88,9 (3.50)	8,7 (0.34)
C-16-5S	100,8 (3.97)	51,4 (2.02)	113,5 (4.47)	50,0 (1.97)	25,0 (0.99)	16,9 (.066)	58,8 (2.34)	36,1 (1.42)	81,3 (3.20)	10,2 (0.40)	101,6 (4.00)	12,7 (0.50)	88,9 (3.50)	8,7 (0.34)
C-20-5S	113,5 (4.47)	56,8 (2.24)	126,2 (4.97)	75,4 (2.97)	37,7 (1.49)	16,8 (0.66)	62,3 (2.45)	37,6 (1.48)	87,4 (3.44)	10,2 (0.40)	114,3 (4.50)	12,7 (0.50)	101,6 (4.00)	8,7 (0.34)

Port Dimensions

Key dimensions
in all standard housings

SAE SIZE	THREAD SIZE	MINIMUM SPOTFACE Ø	MINIMUM FULL THD DEPTH
4	0.437"-20 UNF-2B	21,1 (0.82)	11,5 (0.45)
6	0.563"-18 UNF-2B	24,7 (0.96)	12,7 (0.50)
8	0.750"-16 UNF-2B	30,2 (1.18)	14,2 (0.56)
10	0.875"-14 UNF-2B	34,2 (1.34)	16,6 (0.65)
12	1.062"-12 UN-2B	41,3 (1.62)	19,0 (0.75)
16	1.312"-12 UN-2B	48,6 (1.91)	19,0 (0.75)

BSPP THREAD SIZE	MINIMUM SPOTFACE Ø	MINIMUM FULL THD DEPTH
1/4"	24 (0.94)	12,2 (0.48)
3/8"	27 (1.06)	12,2 (0.48)
1/2"	33 (1.29)	15,0 (0.59)
3/4"	42 (1.65)	16,3 (0.64)
1"	47 (1.85)	19,1 (0.75)

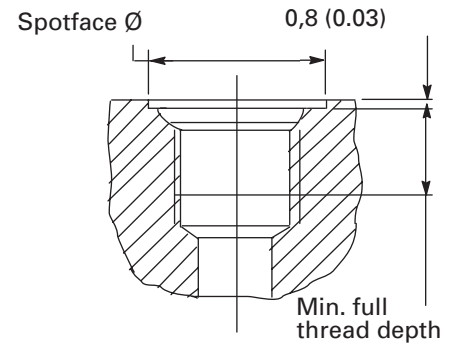

CBV, POC and VCB Housings

Housing part numbers shown on the following pages are for the counterbalance, vented counterbalance, and pilot-to-open check valves (CBV1/2, VCB1, POC1). Housing dimensions for inline housings are shown on pages J6, J7 and J9. Dimensions for other housings are shown on pages J-18 to J-35.

CBV1/2, POC1 VALVE HOUSINGS

HOUSING TYPE	PORT SIZE	SIZE 10 ALUMINUM LIGHT DUTY	SIZE 10 ALUMINUM	SIZE 10 STEEL	SIZE 12 ALUMINUM	SIZE 12 STEEL
I	3B (3/8" BSPP)	02-175470	-	-	-	-
Inline	6H (SAE 6)	-	876706	-	-	-
Mounted	8H (SAE 8)	-	876712	-	-	-
	6T (SAE 6)	566413	-	02-171961	-	-
	8T (SAE 8)	-	-	02-163322	-	-
	10T (SAE 10)	-	-	02-163323	02-178268	02-160996
	12T (SAE 12)	-	-	-	02-178269	02-160997
	2G (1/4" BSPP)	-	876707	-	-	-
	3G (3/8" BSPP)	-	876710	02-163313	-	-
	4G (1/2" BSPP)	-	-	02-163324	02-178270	02-160994
	6G (3/4" BSPP)	-	-	-	02-178271	02-160995
B-4-Bolt Pad	6T (3/4" SAE code 61 flange, SAE4 pilot port)	-	-	-	02-160801	02-160800
N	6H (SAE 6)	-	02-160853	-	-	-
Close Coupled,	6T (SAE 6)	-	-	02-160851	-	-
Nipple Mounted	8T (SAE 8)	-	-	-	02-160820	02-160818
	3G (3/8" BSPP)	-	02-172324	02-172323	-	-
	4G (1/2" BSPP)	-	-	-	02-160821	02-160819
G	6H (SAE 6)	-	02-160845	-	-	-
Gasket	6T (SAE 6)	-	-	02-160848	-	-
Mounted,	8T (SAE 8)	-	-	-	02-160824	02-160822
Single	3G (3/8" BSPP)	-	02-160844	02-160847	-	-
	4G (1/2" BSPP)	-	-	-	02-160825	02-160823



CBV, POC and VCB Housings (cont.)

CBV1/2, POC1

HOUSING TYPE	PORT SIZE	SIZE 10 ALUMINUM LIGHT DUTY	SIZE 10 ALUMINUM	SIZE 10 STEEL	SIZE 12 ALUMINUM	SIZE 12 STEEL
D	6H (SAE 6)	–	02–160829	–	–	–
Dual Line	8H (SAE 8)	–	02–160830	–	–	–
Mounted	10H (SAE 10)	–	02–160831	–	–	–
	6T (SAE 6)	–	–	02–160838	–	–
	8T (SAE 8)	–	–	02–160839	–	–
	10T (SAE 10)	–	–	02–160840	02–160811	02–160808
	12T (SAE 10)	–	–	–	02–160812	02–160809
	2G (1/4" BSPP)	–	02–171912	02–160841	–	–
	3G (3/8" BSPP)	–	02–160833	02–160842	–	–
	4G (1/2" BSPP)	–	02–160834	02–160843	02–160813	02–160810
P	6H (SAE 6)	–	02–160876	–	–	–
Dual Gasket	6T (SAE 6)	–	–	02–160873	–	–
Mounted	8T (SAE 8)	–	–	–	02–160816	02–160814
	3G (3/8" BSPP)	–	02–160877	02–160874	–	–
	4G (1/2" BSPP)	–	–	–	02–160817	02–160815
M	6H (SAE 6)	–	02–160857	–	–	–
Dual	8H (SAE 8)	–	02–160858	–	–	–
Counterbalance	10H (SAE 10)	–	02–160859	–	–	–
Line Mounted	6T (SAE 6)	–	–	02–160866	–	–
w/Integral	8T (SAE 8)	–	–	02–160867	–	–
Shuttle Valve	10T (SAE 10)	–	–	02–160868	02–160805	02–160802
	12T (SAE 10)	–	–	–	02–160806	02–160803
	2G (1/4" BSPP)	–	02–160860	02–160869	–	–
	3G (3/8" BSPP)	–	02–160861	02–160870	–	–
	4G (1/2" BSPP)	–	02–160862	02–160871	02–160807	02–160804
H	10T (SAE 10)	–	4997072-0001	–	–	–
2K	10T (SAE 10)	–	4997070-0001	–	–	–
Dual						
Counterbalance						
Bolt on Manifolds						
for Eaton						
Hydraulic Motors						

VCB VALVE HOUSINGS

HOUSING TYPE	PORT SIZE	SIZE 10 ALUMINUM LIGHT DUTY	SIZE 10 ALUMINUM	SIZE 10 STEEL	SIZE 12 ALUMINUM	SIZE 12 STEEL
I	6H (SAE 6)	–	876708	–	–	–
Inline	8H (SAE 8)	–	*02-178190	–	–	–
Mounted	10H (SAE 10)	–	*01-178192	–	–	–
	6T (SAE 6)	566160	–	–	–	–
	8T (SAE 8)	–	–	*02-178191	–	–
	10T (SAE 10)	–	–	*02-178193	02-178739	02-178732
	12T (SAE 12)	--	–	–	*02-178740	*02-178733

CBV, POC and VCB Housings (cont.)

VCB valve housings

HOUSING TYPE	PORT SIZE	SIZE 10 ALUMINUM LIGHT DUTY	SIZE 10 ALUMINUM	SIZE 10 STEEL	SIZE 12 ALUMINUM	SIZE 12 STEEL
I	2G (1/4" BSPP)	–	876709	–	–	–
	3G (3/8" BSPP)	–	*02-178194	*02-178195	–	–
	4G (1/2" BSPP)	–	–	–	*02-178741	*02-178734
G	6H (SAE 6)	–	02-160986	–	–	–
Gasket	8H (SAE 8)	–	02-160987	–	–	–
Mounted,	6T (SAE 6)	–	–	02-178166	–	–
Single	8T (SAE 8)	–	–	02-178167	02-178905	02-178904
	3G (3/8" BSPP)	–	02-160989	02-178169	–	–
	4G (1/2" BSPP)	–	–	–	02-178903	02-178906
D	6H (SAE 6)	–	02-160990	–	–	–
Dual Line	8H (SAE 8)	–	02-160991	–	–	–
Mounted	6T (SAE 6)	–	–	02-178170	–	–
	8T (SAE 8)	–	–	02-178171	–	–
	10T (SAE 10)	–	–	–	02-178915	02-178916
	12T (SAE 12)	–	–	–	*02-178917	*02-178918
	3G (3/8" BSPP)	–	02-160993	02-178173	–	–
	4G (1/2" BSPP)	--	–	–	*02-178919	*02-178920

* Housings with slot

APPROXIMATE WEIGHT KG. (LBS) FOR CBV, POC & VCB VALVE HOUSINGS

HOUSING	ALUMINUM STANDARD CBV/POC			ALUMINUM STANDARD VCB		ALUMINUM LIGHT DUTY	STEEL CBV/POC			STEEL VCB	
	SIZE 10	SIZE 12	SIZE 16	SIZE 10	SIZE 12	SIZE 10	SIZE 10	SIZE 12	SIZE 16	SIZE 10	SIZE 12
I	0,75 (1.65)	0,82 (1.80)	1,18 (2.60)	0,85 (1.87)	0,95 (2.09)	0,23 (0.51)	1,08 (2.40)	2,63 (5.40)	3,40 (7.50)	1,23 (2.71)	3,05 (6.72)
B	–	0,86 (1.90)	–	–	–	–	–	2,61 (5.75)	–	–	–
N	0,49 (1.10)	0,91 (2.00)	–	–	–	–	1,49 (3.30)	2,72 (6.00)	–	–	–
G	0,67 (1.85)	0,73 (1.60)	–	0,85 (1.87)	0,95 (2.09)	–	2,49 (5.50)	2,15 (4.75)	–	1,23 (2.71)	3,05 (6.72)
D	0,79 (1.75)	1,11 (2.45)	1,77 (3.90)	1,60 (3.52)	1,10 (2.42)	–	2,38 (5.25)	3,33 (7.35)	5,14 (11.30)	2,55 (5.62)	3,70 (8.15)
P	0,72 (1.60)	2,0 (4.40)	–	–	–	–	2,17 (4.80)	5,90 (10.00)	–	–	–
H	1,24 (2.73)	–	–	–	–	–	–	–	–	–	–
2K	1,67 (3.67)	–	–	–	–	–	–	–	–	–	–

J

Size 10 Housings

CBV1/2 and POC1

I – Inline, aluminum & steel

PORT SIZE	1	2	3
6T	SAE 6	SAE 6	SAE 6
3B	3/8" BSPP	3/8" BSPP	3/8" BSPP

See standard inline housings:
 Light duty housings - page J-6
 Fatigue rated housings - page J-7
 Steel housings - page J-9

N - Close coupled nipple mounted - aluminum and steel (NFPA fatigue rated)

PORT SIZE	ALUMINUM	STEEL	C1	C2,V1,V2
6H	6T	6T	SAE 8	SAE 6
3G	3G	3G	3/8" BSPP	3/8" BSPP

See page J-15 for housing part numbers.

Dimensions

mm (inch)

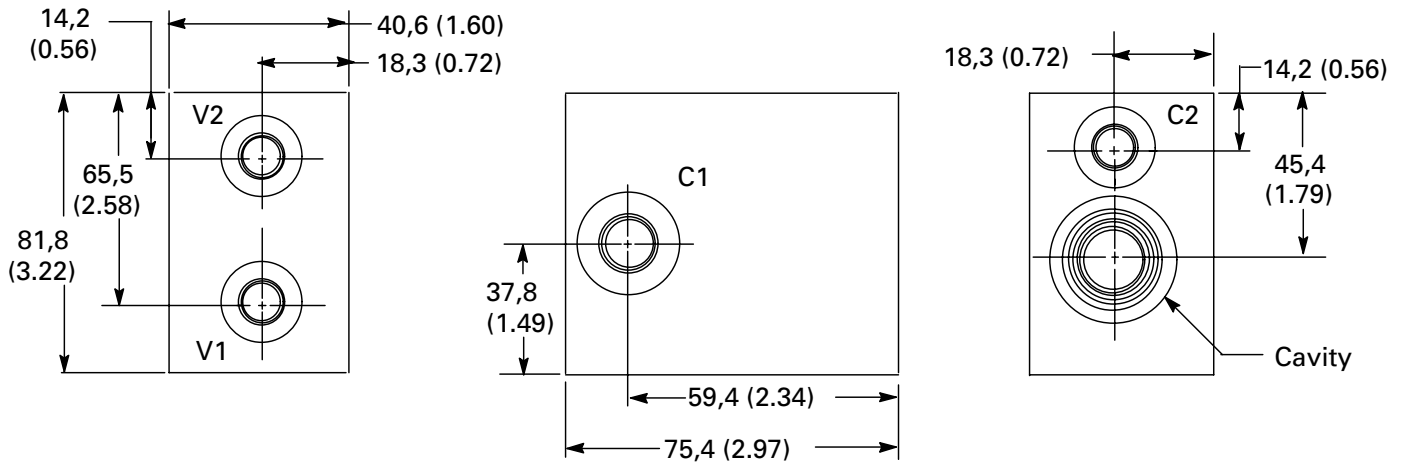

Size 10 Housings

CBV1/2 and POC1

G - Gasket mounted, single - aluminum and steel (NFPA fatigue rated)

PORT SIZE ALUMINUM	STEEL	C1	C2,V1,V2
6H	6T	Ø 12,7(0.5)	SAE 6
3G	3G	Ø 12,7(0.5)	3/8" BSPP

See page J-15 for housing part numbers.

Dimensions

mm (inch)

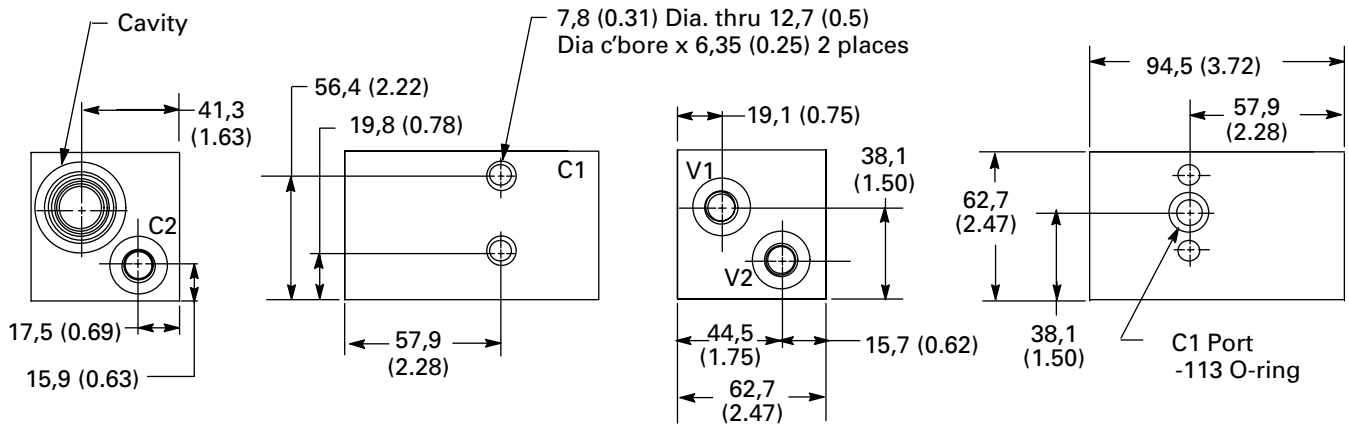

D - Dual line mounted - aluminum and steel (NFPA fatigue rated)

PORT SIZE ALUMINUM	STEEL	C1,C2,V1,V2
6H	6T	SAE 6
8H	8T	SAE 8
10H	10T	SAE 10
2G	2G	1/4" BSPP
3G	3G	3/8" BSPP
4G	4G	1/2" BSPP

See page J-15 for housing part numbers.

Dimensions

mm (inch)

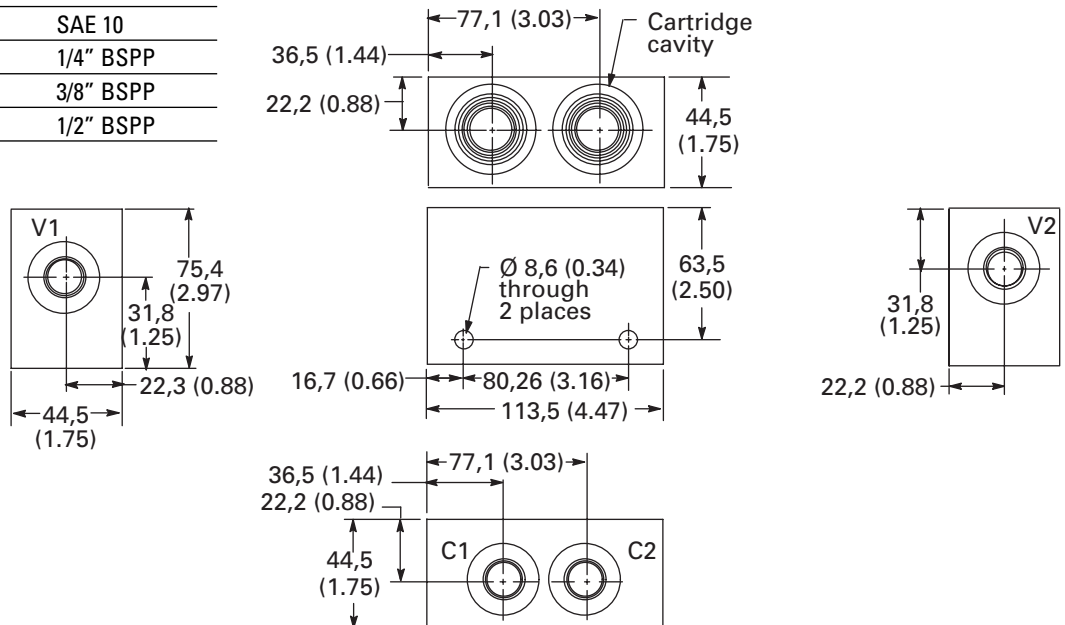

Size 10 Housings

CBV1/2 and POC1

P - Dual gasket mounted - aluminum and steel (NFPA fatigue rated)

PORT SIZE	ALUMINUM	STEEL	C1	C2,V1,V2
6H	6T	6T	Ø 12,7(0.5)	SAE 6
3G	3G	3G	Ø 12,7(0.5)	3/8" BSPP

See page J-15 for housing part numbers.

Dimensions

mm (inch)

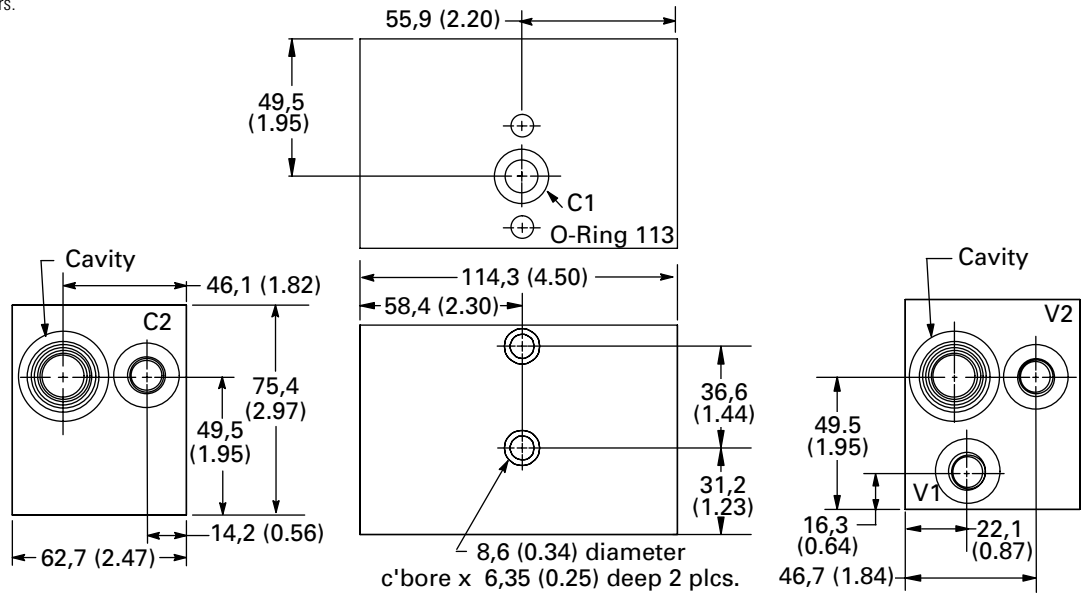

M - Dual line mounted - aluminum and steel (NFPA fatigue rated)

PORT SIZE	ALUMINUM	STEEL	C1,C2, V1,V2	S
6H	6T	6T	SAE 6	SAE 4
8H	8T	8T	SAE 8	SAE 4
10H	10T	10T	SAE 10	SAE 4
2G	2G	2G	1/4" BSPP	1/4" BSPP
3G	3G	3G	3/8" BSPP	1/4" BSPP
4G	4G	4G	1/2" BSPP	1/4" BSPP

See page J-15 for housing part numbers.

Dimensions

mm (inch)

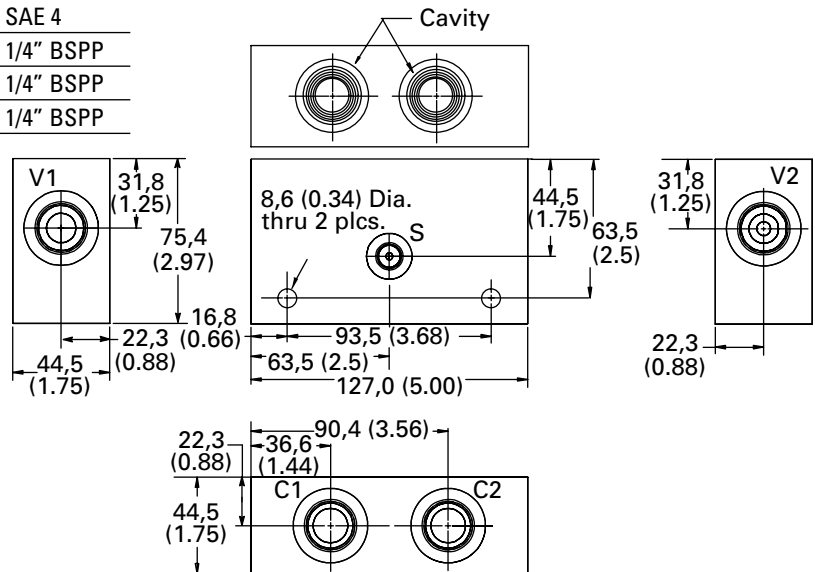

Size 12 Housings

CBV1/2 and POC1

I - Inline body - aluminum and steel (NFPA fatigue rated)

PORT SIZE	CYLINDER-PORT (1)	VALVE-PORT (2)	PILOT-PORT (3)
10T	SAE 10		SAE 6
12T	SAE 12		SAE 6
4G	1/2" BSPP		3/8" BSPP
6G	3/4" BSPP		3/8" BSPP

See page J-15 for housing part numbers.

See standard inline housings:
Aluminum housings - page J-7
Steel housings - page J-9

B - 3/4" 4-Bolt Pad - aluminum and steel (NFPA fatigue rated)

PORT SIZE	C1	PILOT-PORT
6T	3/4" SAE 4 bolt Code 61	SAE 6

See page J-15 for housing part numbers.

Dimensions

mm (inch)

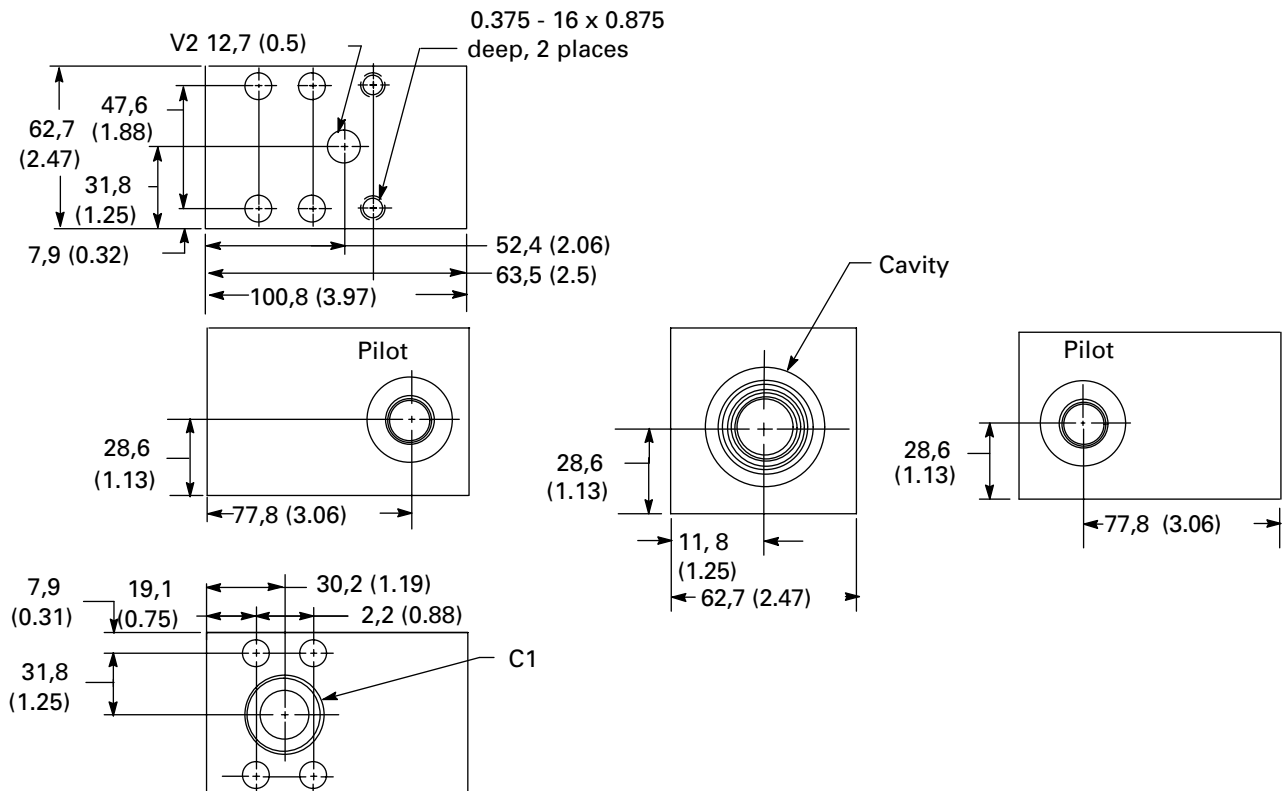

Size 12 Housings

CBV1/2 and POC1

N - Close coupled nipple mounted - aluminum and steel (NFPA fatigue rated)

PORT SIZE	C1	C2, V1, V2
8T	1/2" NPTF	SAE 8
4G	1/2" BSPP	1/2" BSPP

See page J-15 for housing part numbers.

Dimensions

mm (inch)

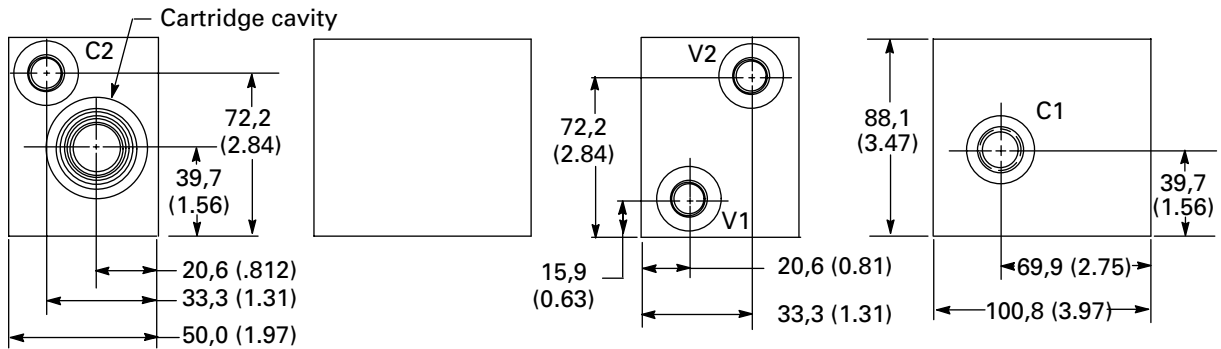

G - Gasket mounted, single - aluminum and steel (NFPA fatigue rated)

PORT SIZE	C1	C2, V1, V2
8T	Ø 15,8(0.625)	SAE 8
4G	Ø 15,8(0.625)	1/2" BSPP

See page J-15 for housing part numbers.

Dimensions

mm (inch)

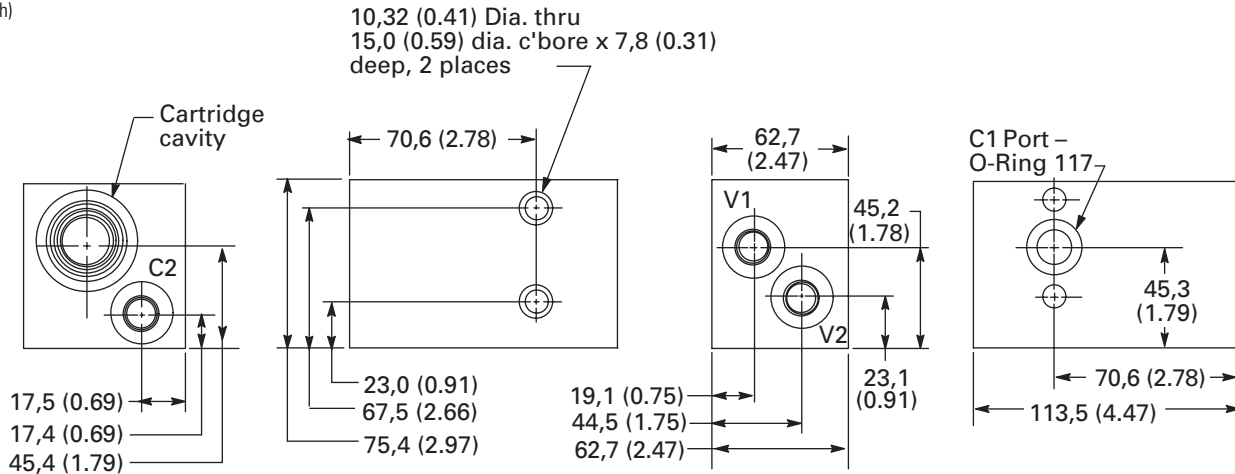

Size 12 Housings

CBV1/2 and POC1

D - Dual line mounted - aluminum and steel (NFPA fatigue rated)

PORT SIZE	C1, C2, V1, V2
10T	SAE 10
12T	SAE 12
4G	1/2" BSPP

See page J-15 for housing part numbers.

Dimensions

mm (inch)

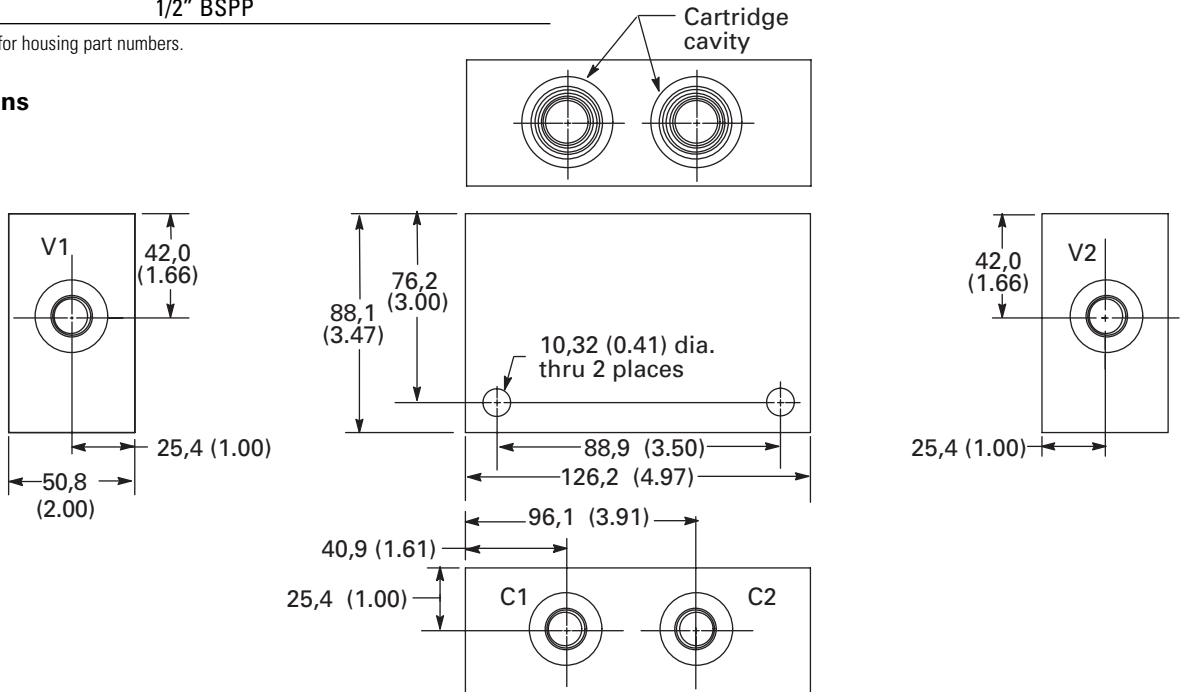

P - Dual gasket mounted (NFPA fatigue rated)

PORT SIZE	C1	C2, V1, V2
8T	Ø 15,8(0.625)	SAE 8
4G	Ø 15,8(0.625)	1/2" BSPP

See page J-15 for housing part numbers.

Dimensions

mm (inch)

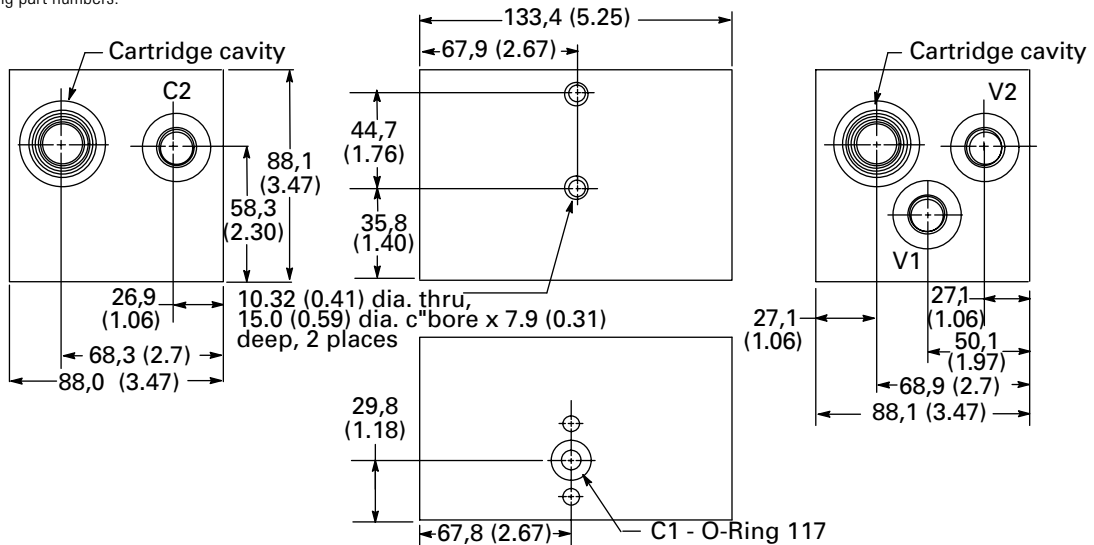

J

Size 12 Housings

CBV1/2 and POC1

M - dual line mounted - with integral shuttle, counter balance only (NFPA fatigue rated)

PORT SIZE	C1,C2 V1, V2	S
10T	SAE 10	SAE 4
12T	SAE 12	SAE 4
4G	1/2" BSPP	1/4" BSPP

See page J-15 for housing part numbers.

Dimensions

mm (inch)

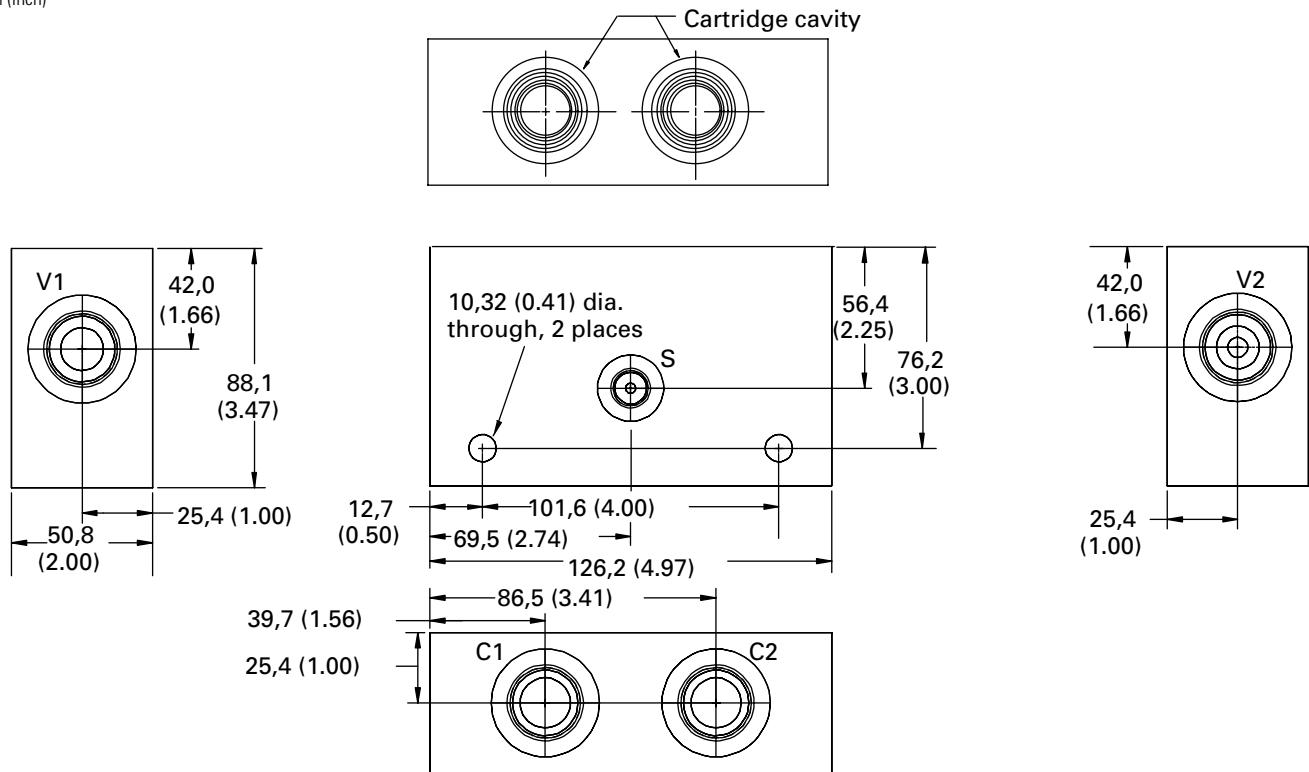

Size 10 Housings

VCB1-10

I - Inline body - aluminum, light duty

PORT SIZE	1, 2, 3 & 4
6T	SAE 6

See page J-15 for housing part numbers.

Dimensions

mm (inch)

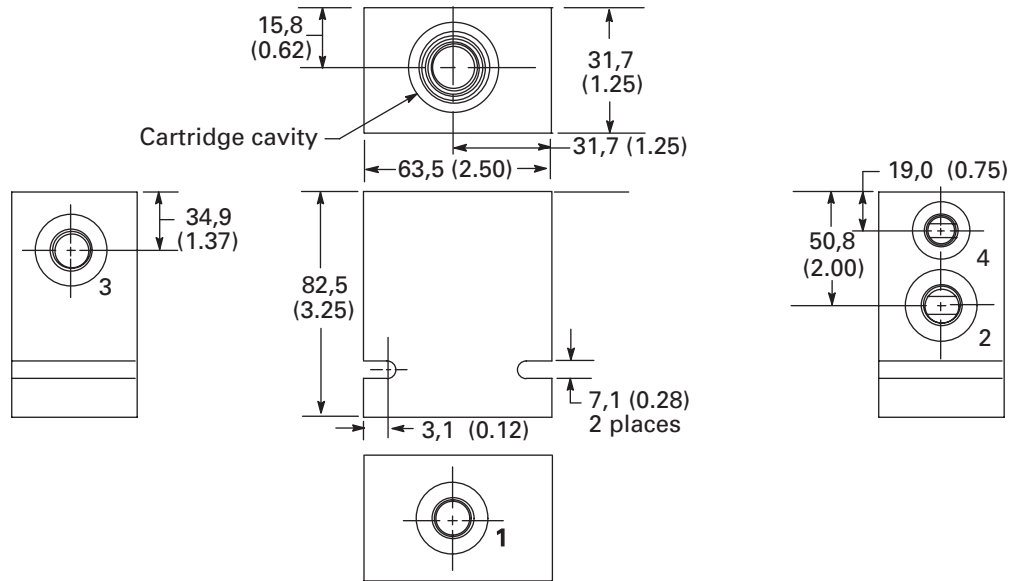

I - Inline body - aluminum (NFPA Fatigue Rated)

PORT SIZE	1 & 2	3 & 4
8H	SAE 8	SAE 6
10H	SAE 10	SAE 6
3G	3/8" BSPP	1/4" BSPP

See page J-15 for housing part numbers.

Dimensions

mm (inch)

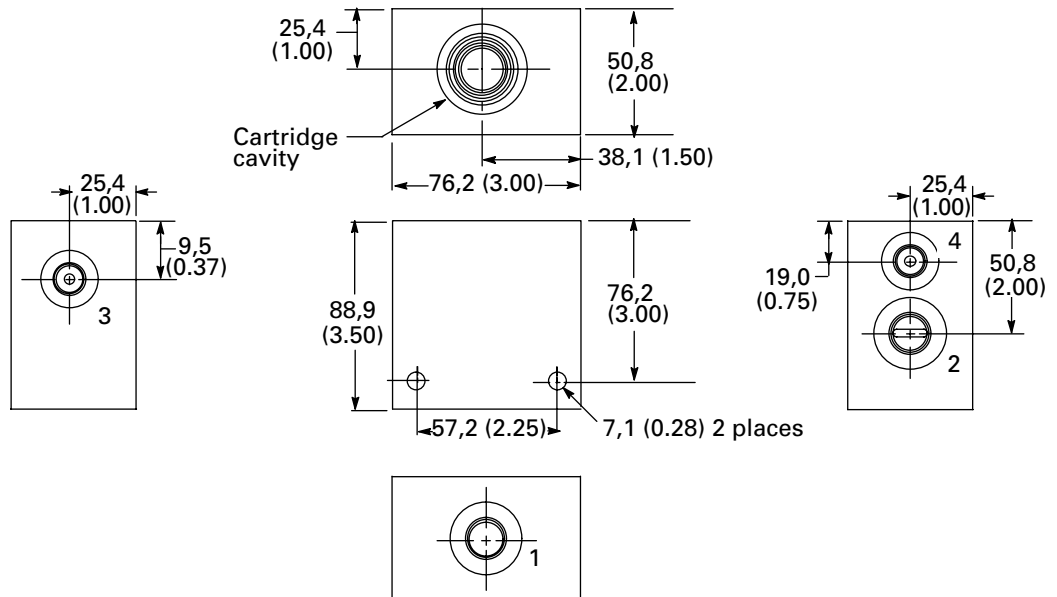

Size 10 Housings

VCB1

I - Inline body - Steel (NFPA fatigue rated)

PORT SIZE	1 & 2	3 & 4
6T	SAE 8	SAE 6
8T	SAE 10	SAE 6
3G	3/8" BSPP	1/4" BSPP

See page J-15 for housing part numbers.

Dimensions

mm (inch)

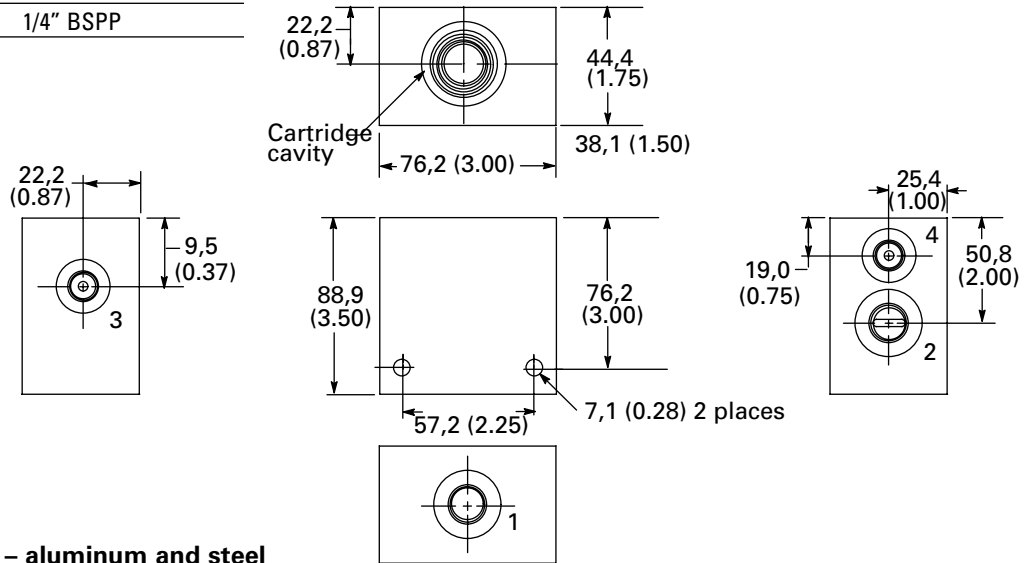

G - Gasket mounted, single – aluminum and steel (NFPA fatigue rated)

PORT SIZE	STEEL	VENT	C1	C2, V1, V2
6H	6T	SAE 6	Ø 12,7 (0.500)	SAE 6
N/A	8T	SAE 6	Ø 12,7 (0.500)	SAE 8
3G	3G	1/4" BSPP	Ø 12,7 (0.500)	3/8" BSPP

See page J-15 for housing part numbers.

Dimensions

mm (inch)

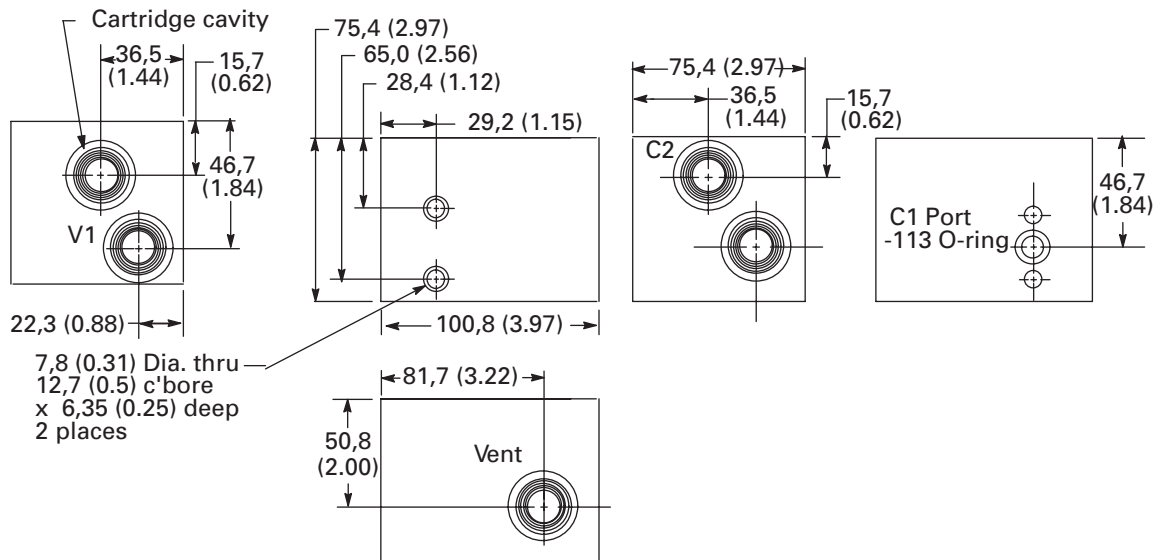

Size 10 Housings

VCB1

D - Dual line mounted - aluminum and steel (NFPA fatigue rated)

PORT SIZE ALUMINUM	STEEL	C1, C2, V1 & V2	VENT
6H	6T	SAE 6	SAE 4
8H	8T	SAE 8	SAE 4
3G	3G	3/8" BSPP	1/4" BSPP

See page J-15 for housing part numbers.

Dimensions

mm (inch)

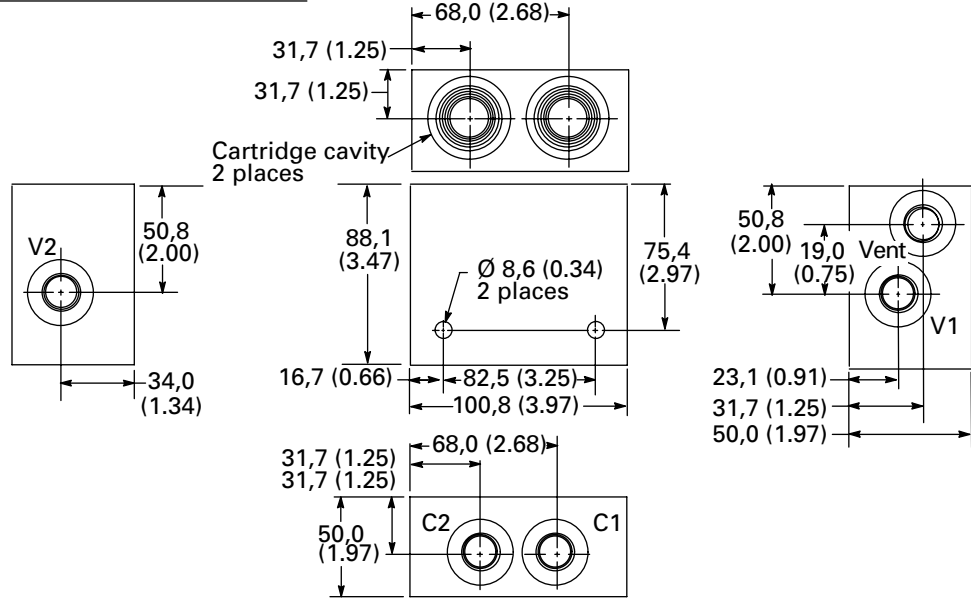

Size 12 Housings

VCB1

Dimensions

mm (inch)

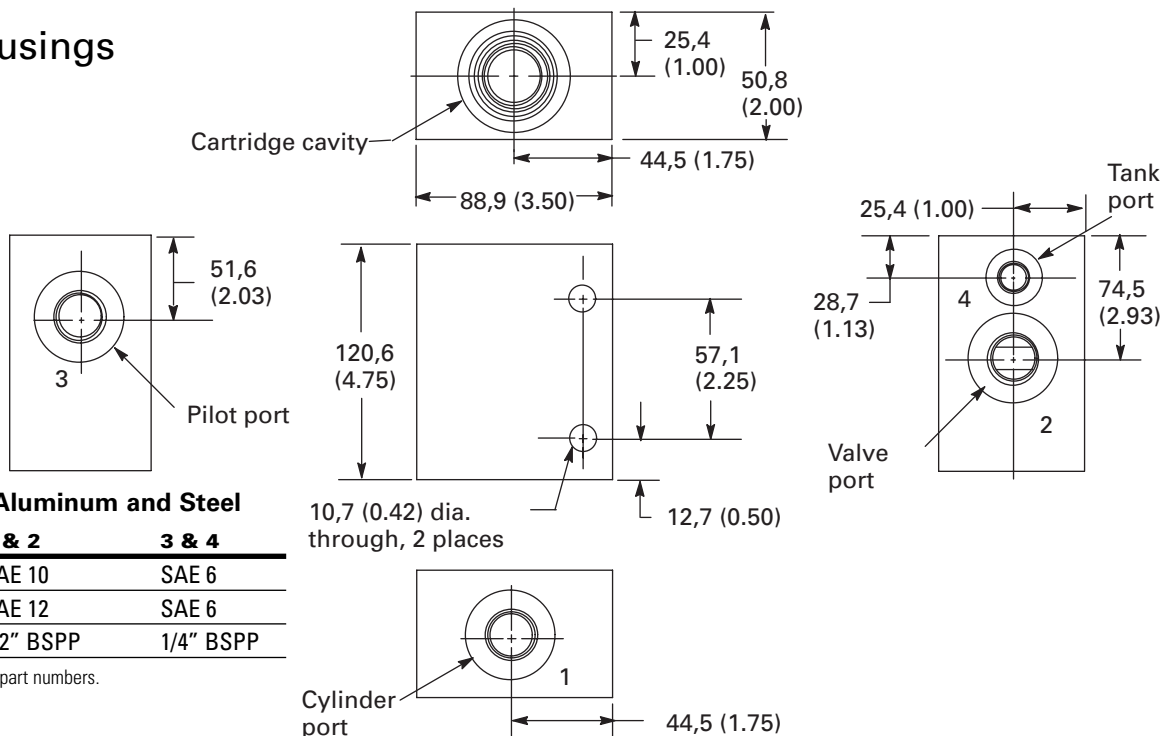

I - In-line body - Aluminum and Steel

PORT SIZE	1 & 2	3 & 4
10T	SAE 10	SAE 6
12T	SAE 12	SAE 6
4G	1/2" BSPP	1/4" BSPP

See page J-15 for housing part numbers.



Size 12 Housings

VCB1

G - Gasket mounted, single – aluminum and steel (NFPA fatigue rated)

PORT SIZE	VENT	C1	C2, V1, V2
8T	SAE 6	Ø 15,8(0.625)	SAE 8
4G	1/4" BSPP	Ø 15,8(0.625)	1/2" BSPP

See page J-15 for housing part numbers.

Dimensions

mm (inch)

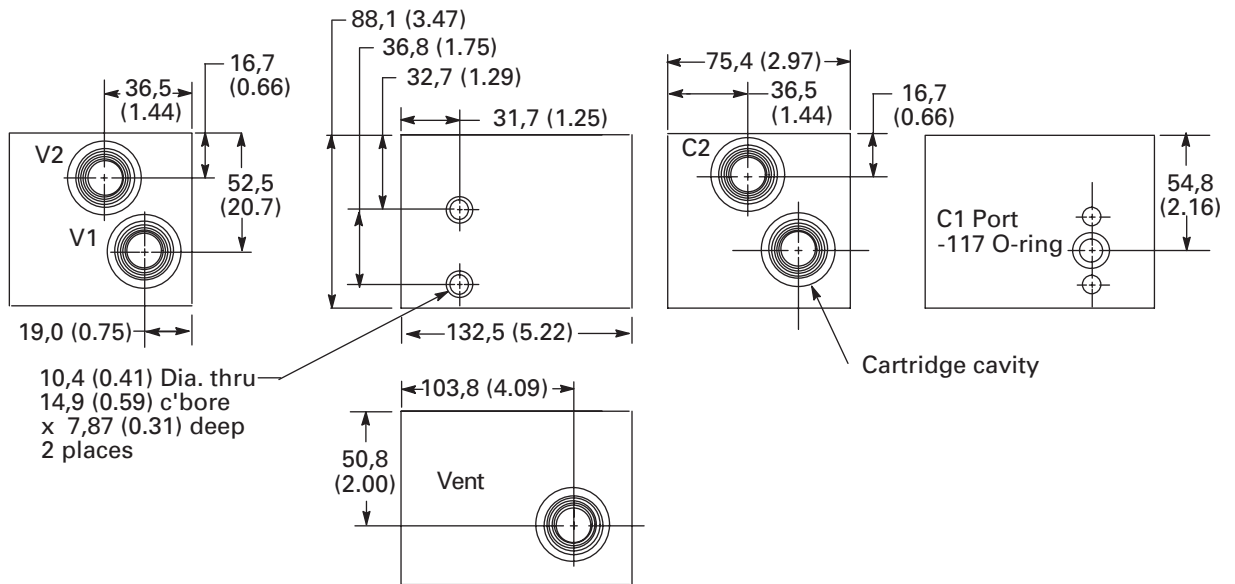

D - Dual line mounted - aluminum and steel (NFPA fatigue rated)

PORT SIZE	C1, C2, V1 & V2	VENT
10T	SAE 10	SAE 6
12T	SAE 12	SAE 6
4G	1/2" BSPP	1/4" BSPP

See page J-15 for housing part numbers.

Dimensions

mm (inch)

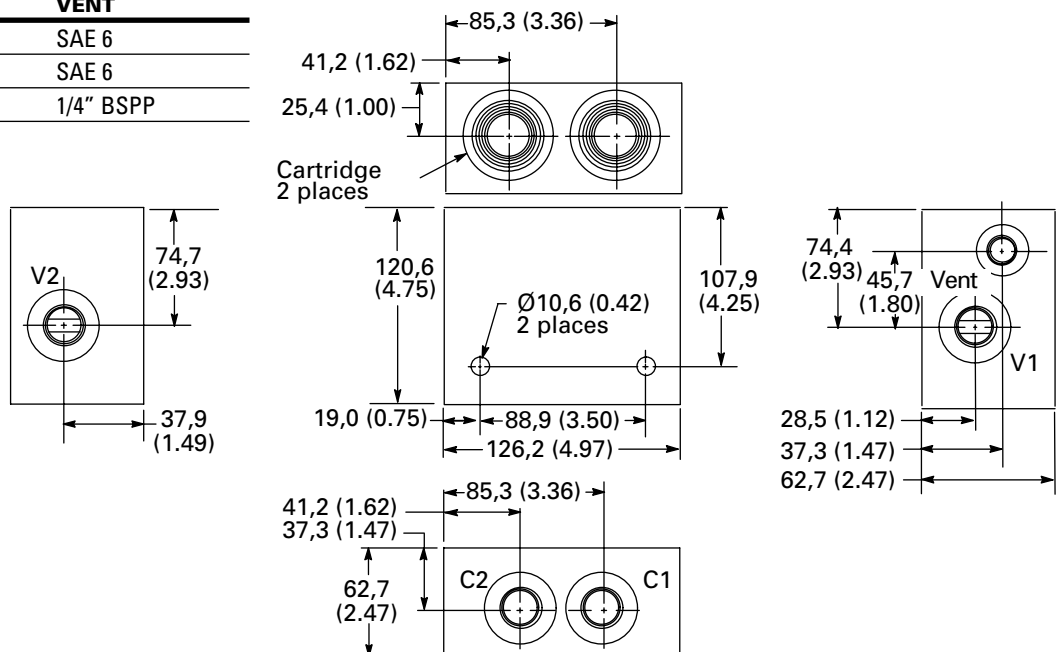

Special Housings Bolt on Solutions

Cartridge Valves &
Manifolds for Spool
& Disk Valve Motors

We Manufacture Solutions

Designing hydraulic systems with Eaton-Vickers Cartridge Valves & Manifolds is a cost effective way of bringing your design into production well within the most demanding of production schedules. Minimizing the use of hoses, tubing and fittings will reduce production and assembly time significantly.

Features

- Compatible with Eaton H & T series spool valve motors, and most 2000 series disk valve motors
- Aluminum Manifolds Anodized Black
- Pre-set cartridges to your specifications
- 100% production tested assembly
- Wide range of settings available
- Intelligent model code
- Manifolds are available with out cartridge valves, or pre-assembled and tested to your specifications
- Manifolds and motors can be supplied as a pre-assembled package
- Dual counterbalance valve (with integral shuttle valve), dual pilot operated check valve and dual cross port relief valve packages are available

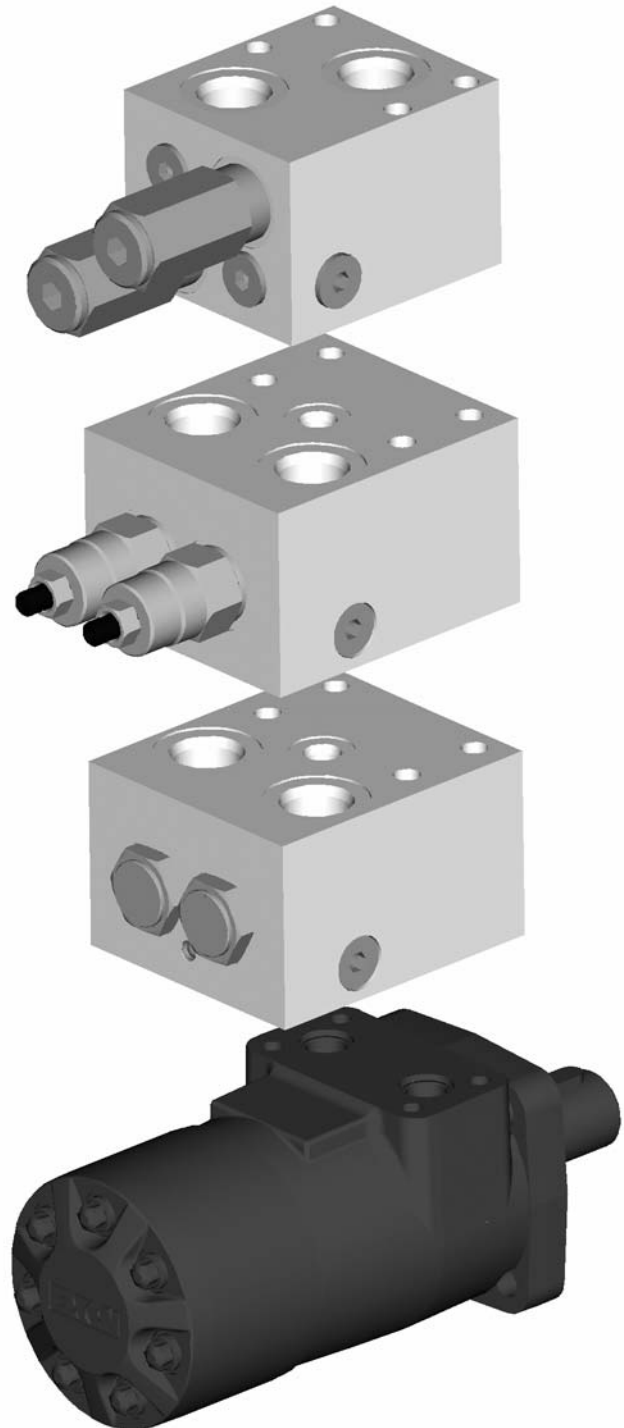

Eaton H Series Hydraulic Motor

Dual CBV Package for H&T Series Motors

Cartridge valves & manifolds for spool valve motors

Dual Counterbalance Valve Assembly with Brake Release Shuttle

When the motor is in a stationary, unpowered mode, this assembly will prevent excessive drift in either direction of rotation. It will also prevent motor overspeed when exposed to an overrunning load, and will control motor deceleration to a stop. A shuttle within the assembly provides a pilot to release a parking or holding brake as either motor port is pressurized. Typical applications are swing drives, winch drives, and vehicle propulsion circuits. If the shuttle is not required the "Brake" port may be plugged.

Functional Symbol

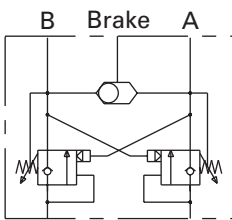

How to Order

Complete pre-assembled packages are specified using the CBV*-10 model code, position 6 of

the model code is "H". To order the manifold sub-assembly, without the two CBV valves, but with

integral shuttle valve order 4997072-001.

RATINGS AND SPECIFICATIONS

Rated flow	60L/min(15USgpm)
Rated pressure	210 bar (3000 psi)
Internal leakage (maximum)	5 drops/min max @ 77% of crack pressure
Pilot ratio	4:1 or 10:1
Manifold sub-assembly only	4997072-001
Installation kit (includes cap screws, washers and o-rings)	4997242-001

For detailed specifications refer to the CBV*-10 data sheet on page H-6

Dimensions

mm (inch)

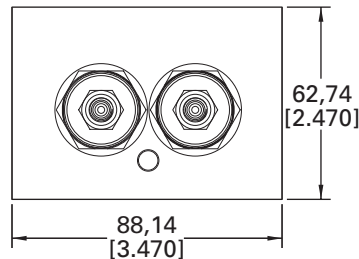

Port Sizes

"A", "B" – SAE10
"Brake" – SAE4

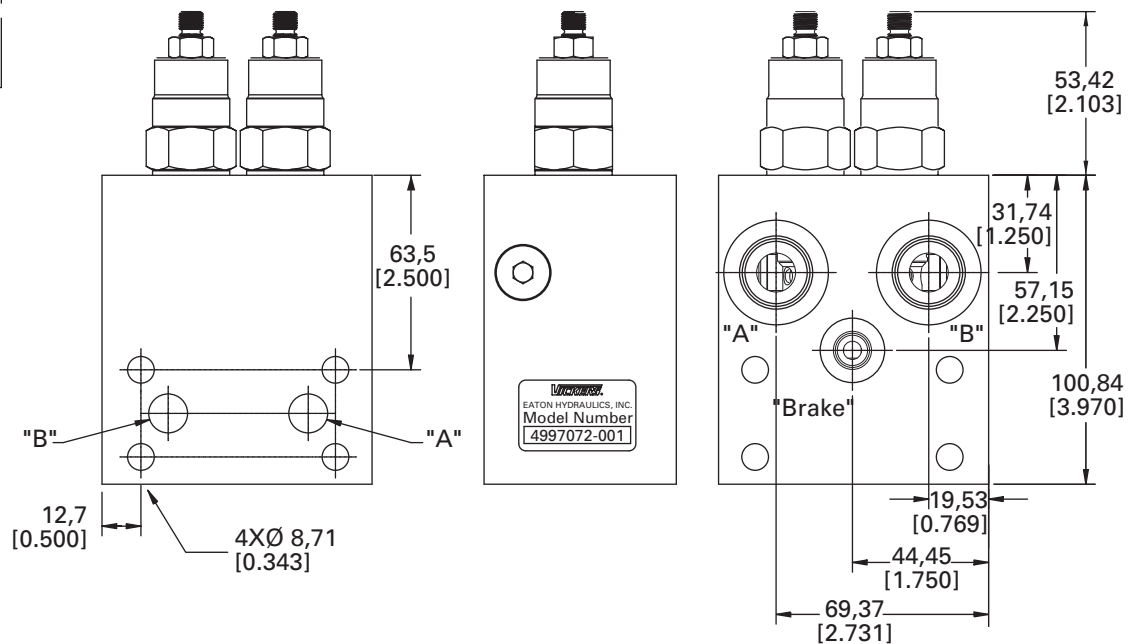

Dual POC Package for H&T Series Motors

Cartridge valves and manifolds for spool valve motors

Dual Pilot Operated Check Valve Assembly

When the motor is in a stationary, unpowered mode, this assembly will prevent excessive drift in either direction of rotation. Although it not designed to modulate the flow of oil to or from the motor, it will also prevent motor run-away if an overrunning load exists in the powered mode. A shuttle within the assembly provides a pilot to release a parking or holding brake as either motor port is pressurized. If the shuttle is not required the "Brake" port may be plugged.

How to Order

Complete pre-assembled packages are specified using the POC1-10 model code, position 6 of the

model code is "H". To order the manifold sub-assembly, without the two POC1 valves, but with integral

shuttle valve order 4997072-001.

RATINGS AND SPECIFICATIONS

Rated flow	60L/min(15USgpm)
Rated pressure	210 bar(3000psi)
Internal leakage (maximum)	less than 5 drops/min @ 3000psi
Pilot ratio	3:1
Manifold sub-assembly	4997072-001
Installation kit (includes cap screws, washers and o-rings)	4997242-001

For detailed specifications refer to the POC1-10 data sheet on page G-36

Dimensions

mm (inch)

Functional Symbol

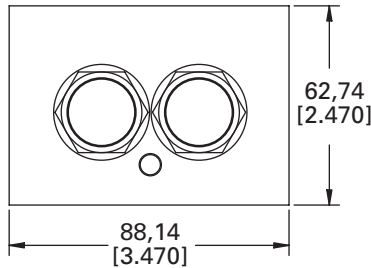
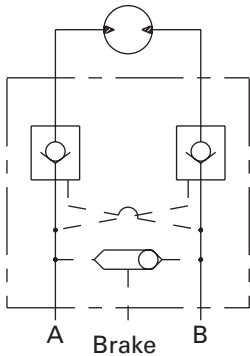

Port Sizes

"A", "B" – SAE10

"Brake" – SAE4

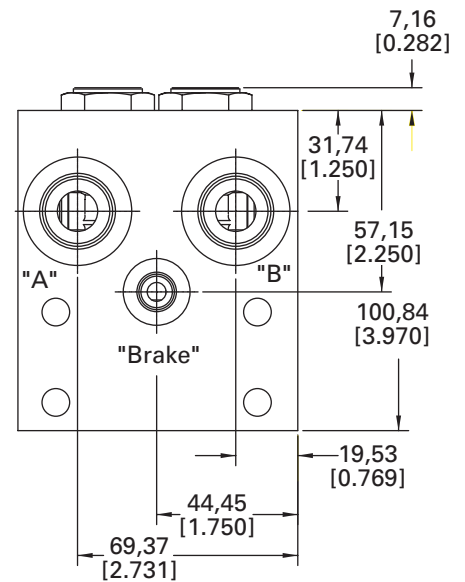
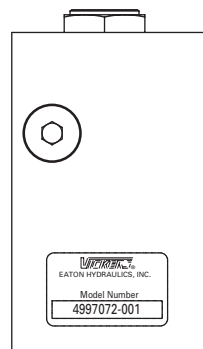
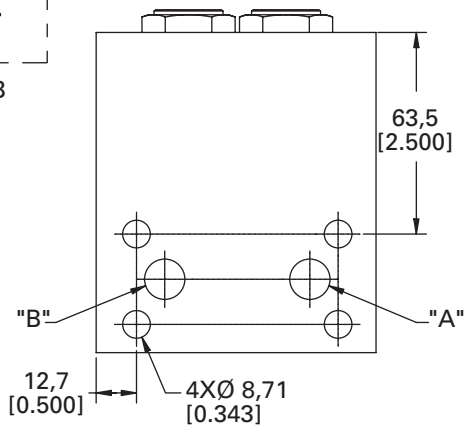

Dual Cross-over Relief Package for H&T Series Motors

Cartridge valves & manifolds for spool valve motors

Dual Crossover Relief Valve Assembly

This valve assembly provides motor over-pressure protection in both directions of rotation, while supplying the return or lower pressure side of the motor with makeup oil. If closed center valving is used, an additional function is controlled braking.

Typical applications are vehicle propulsion and motor work circuits in which pressure limiting is required.

How to Order

Complete pre-assembled packages are specified using the RV3A-10 model code. Option "A" must be

selected for the cage seals, position 6 of the model code is "H". To order the manifold separately,

without the two RV3A cartridges, order the part number 4997062-001.

RATINGS AND SPECIFICATIONS

Rated flow	76 L/min(20USgpm)
Rated pressure	210 bar (3000psi)
Internal leakage (maximum)	less than 5 drops/min @ 85% of nominal setting
Manifold sub-assembly only	4997062-001
Installation kit (includes cap screws, washers and o-rings)	4997242-001

For detailed specifications refer to the RV3A-10 data sheet on page E-12

Dimensions

mm (inch)

Functional Symbol

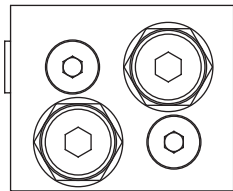
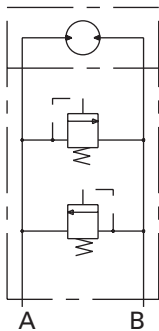

Port Sizes

"A", "B" – SAE10
"Brake" – SAE4

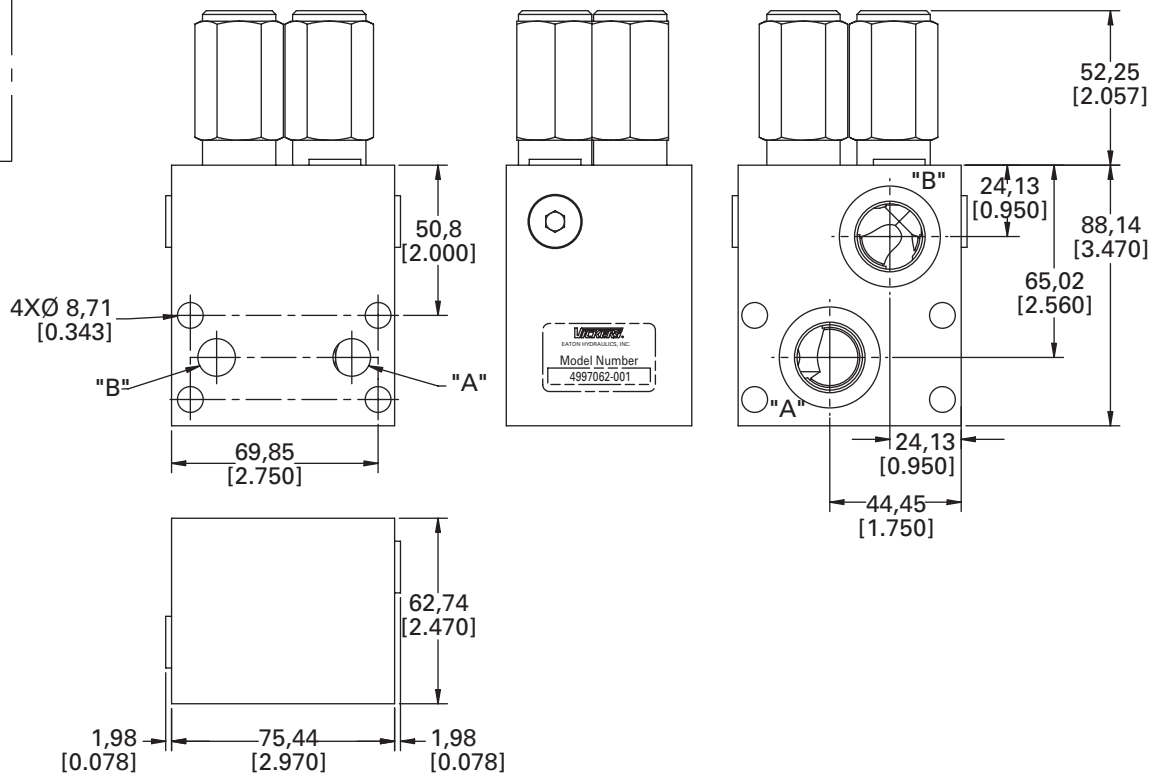

Dual Cross-over Relief Package for 2000 Series Disc Valve Motors

Cartridge valves & manifolds for disc valve motors

Dual Crossover Relief Valve Assembly

This valve assembly provides motor over-pressure protection in both directions of rotation, while supplying the return or lower pressure side of the motor with makeup oil. If closed center valving is used, an additional function is controlled braking.

Typical applications are vehicle propulsion and motor work circuits in which pressure limiting is required.

How to Order

Complete pre-assembled packages are specified using the RV3A-10 model code. Option "A" must be selected for the cage seals,

position 6 of the model code is "2K." To order the manifold separately, without the two RV3A cartridges, order 4997060-001

RATINGS AND SPECIFICATIONS

Rated flow	76 L/min(20USgpm)
Rated pressure	210 bar (3000psi)
Internal leakage (maximum)	less than 5 drops/min @ 85% of nominal setting
Manifold sub-assembly only	4997060-001
Installation kit (includes cap screws, washers and o-rings)	02-372492

For detailed specifications refer to the RV3A-10 data sheet on page E-14

Dimensions

mm (inch)

Functional Symbol

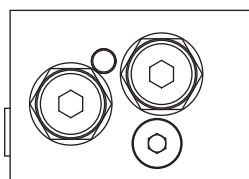
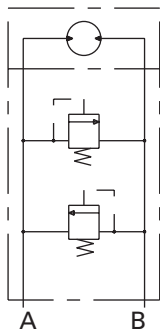

Port Sizes

"A", "B" – SAE10
"Brake" – SAE4



WARNING

This manifold package may not be suitable for application with all 2000 series motors - please check installation dimensions carefully.

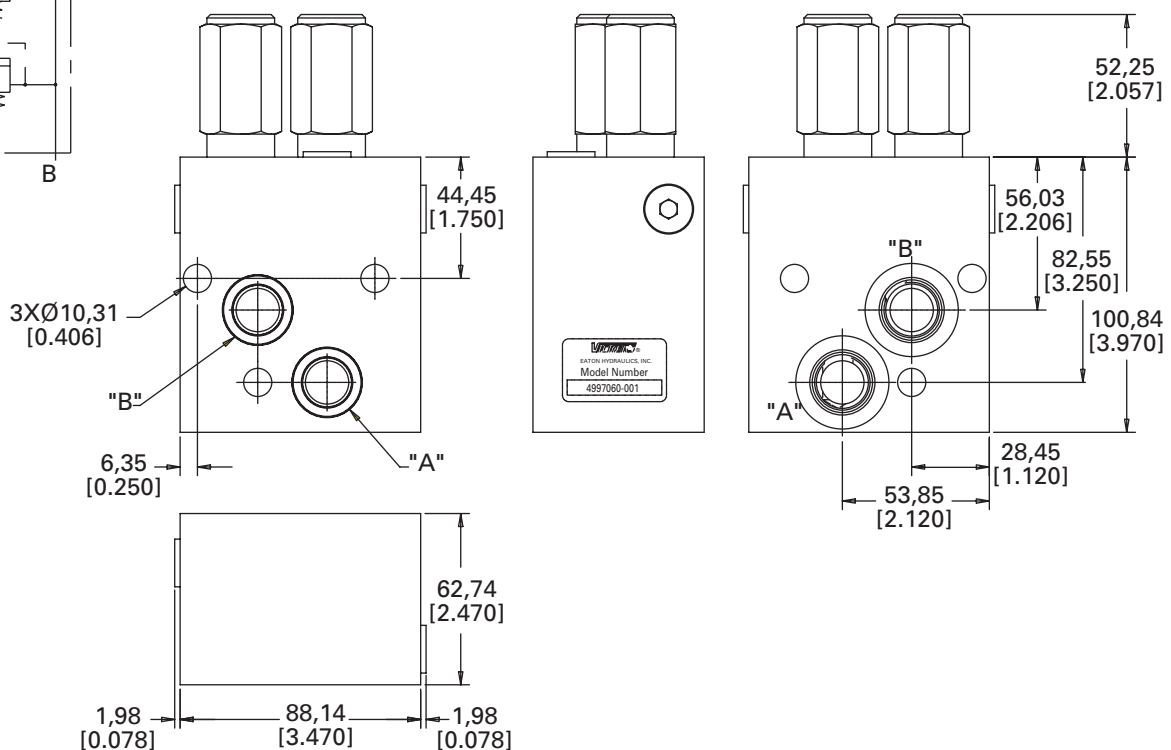

Dual CBV Package for 2000 Series Disc Valve Motors

Cartridge valves &
manifolds for disc
valve motors

Dual Counterbalance Valve Assembly

When the motor is in a stationary, unpowered mode, this assembly will prevent excessive drift in either direction of rotation. It will also prevent motor overspeed when exposed to an overrunning load, and will control motor deceleration to a stop. A shuttle within the assembly provides a pilot to release a parking or holding brake as either motor port is pressurized.

Typical applications are swing drives, winch drives, and vehicle propulsion circuits. If the shuttle is not required the "Brake" port may be plugged.

Functional Symbol

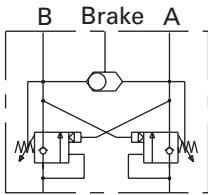

How to Order

Complete pre-assembled packages are specified using the CBV*-10 model code, position 6 of the

model code is "2K". To order the manifold sub-assembly, without the two CBV valves, but with

integral shuttle valve order 4997070-001.

RATINGS AND SPECIFICATIONS

Rated flow	60L/min(15USgpm)
Rated pressure	210 bar (3000 psi)
Internal leakage (maximum)	5 drops/min max @ 77% of crack pressure
Pilot ratio	4:1 or 10:1
Manifold sub-assembly only	4997070-001
Installation kit (includes cap screws, washers and o-rings)	02-372492

For detailed specifications refer to the CBV*-10 data sheet on page H-6

Dimensions

mm (inch)

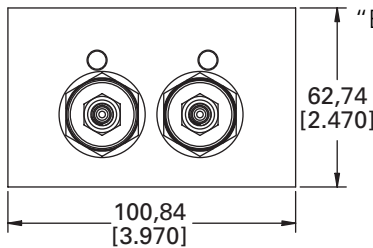

Port Sizes

"A", "B" – SAE10

"Brake" – SAE4



WARNING

This manifold package may not be suitable for application with all 2000 series motors - please check installation dimensions carefully.

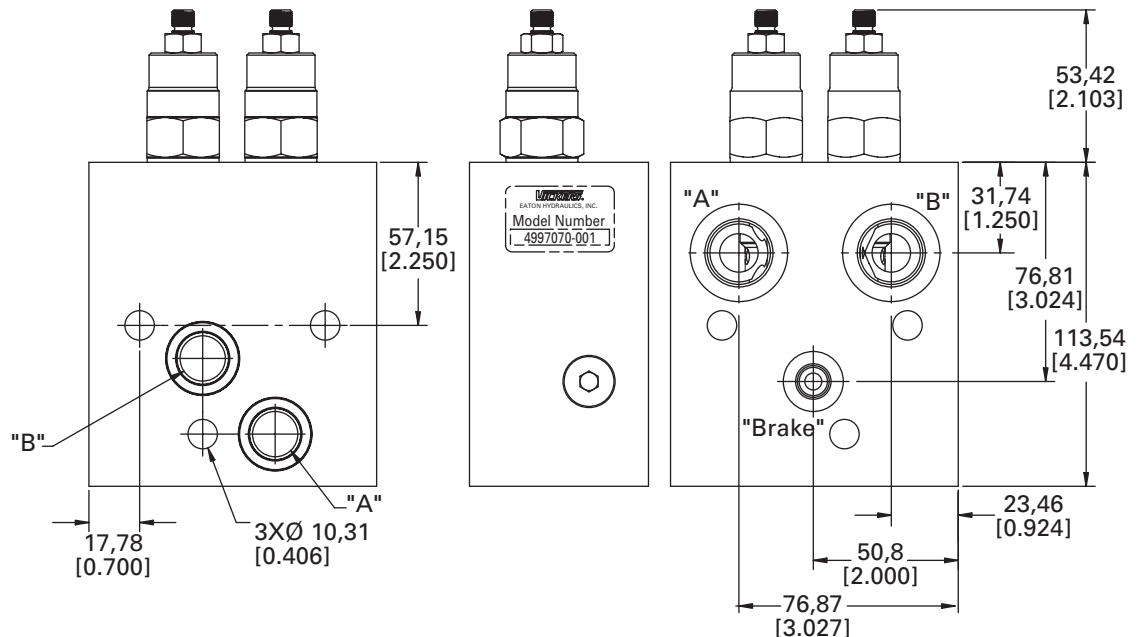

Dual POC Package for 2000 Series Disc Valve Motors

Cartridge valves &
manifolds for disc
valve motors

Dual Pilot Operated Check Valve Assembly

When the motor is in a stationary, unpowered mode, this assembly will prevent excessive drift in either direction of rotation. Although it not designed to modulate the flow of oil to or from the motor, it will also prevent motor run-away if an overrunning load exists in the powered mode. A shuttle within the assembly provides a pilot to release a parking or holding brake as either motor port is pressurized. If the shuttle is not required the "Brake" port may be plugged.

How to Order

Complete pre-assembled packages are specified using the POC1-10 model code, position 6 of the

model code is "2K". To order the manifold sub-assembly, without the two POC1 valves, but with

integral shuttle valve order 4997070-001.

RATINGS AND SPECIFICATIONS

Rated flow	60L/min(15USgpm)
Rated pressure	210 bar(3000psi)
Internal leakage (maximum)	less than 5 drops/min @ 3000psi
Pilot ratio	3:1
Manifold sub-assembly only	4997070-001
Installation kit (includes cap screws, washers and o-rings)	02-372492

For detailed specifications refer to the POC1-10 data sheet on page G-36

Dimensions

mm (inch)

Port Sizes

"A", "B" – SAE10

"Brake" – SAE4

Functional Symbol

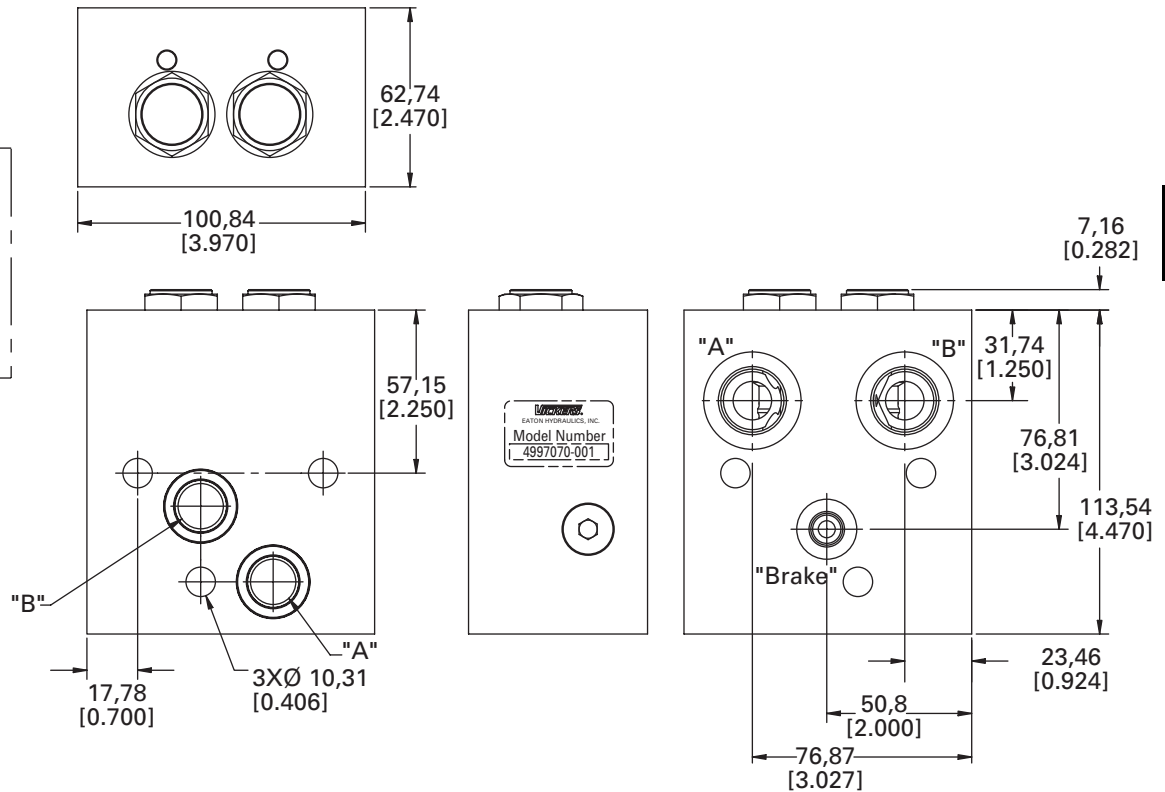
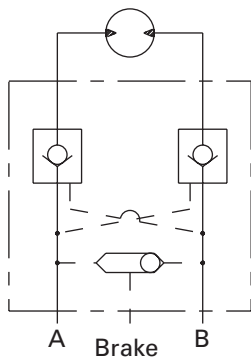

Cavity Plugs

STANDARD PLUGS

Note

To block flow from between the ports in any unused standard cavity, in a housing or manifold. Order cavity plugs by part number.

C-**-2 Cavity Plugs

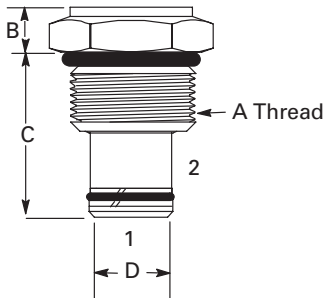

SIZE					ASSY. NO.	SEAL KIT
To fit cavity	A	B	C	øD		Buna-N Viton®
C-8-2	0.750"-16	9,1 (0.36)	27,8 (1.09)	12,6/12,5 (0.498/0.496)	02-171585	02-165877 02-165875
C-10-2	0.875"-14	7,9 (0.30)	31,7 (1.25)	15,8/15,7 (0.62/0.62)	565814	565806 889627
C-12-2	1.062"-12	18,7 (0.74)	44,5 (1.75)	23,7/23,7 (.936/.934)	02-171710	02-165889 02-165888
C-16-2	1.312"-12	12,7 (0.50)	44,5 (1.75)	28,5/28,5 (1.12/1.12)	565816	889631 889635
C-20-2	1.625"-12	13,5 (0.53)	57,2 (2.25)	36,4/36,4 (1.43/1.43)	566440	889639 889643

C-**-3(S) Cavity Plugs

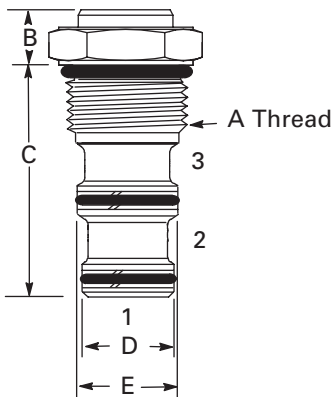

SIZE						ASSY. NO.	SEAL KIT
To fit cavity	A	B	C	D	E		Buna-N Viton®
C-8-3	0.750"-16	9,1 (0.36)	40,7 (1.60)	14,2/14,0 (0.56/0.55)	15,8 (0.623/0.621)	02-171708	02-160755 02-160765
C-10-3S	0.875"-14	7,9 (0.30)	74,2 (1.86)	17,4/17,4 (0.68/0.68)	19,0/18,9 (0.74/0.74)	566436	02-173019 02-173020
C-10-3			46,0 (1.81)	15,8/15,7 (0.62/0.62)	17,4/17,3 (0.68/0.68)	565815	889624 889628
C-12-3S	1.062"-12	18,7 (0.74)	57,7 (2.27)	22,1/22,1 (0.874/0.872)	23,7/23,7 (0.936/0.934)	02-171711	02-180095 02-165887
C-12-3			67,1 (2.64)	-	-	02-171712	02-165872 02-165886
C-16-3S	1.312"-12	12,7 (0.50)	55,6 (2.18)	25,3/25,3 (0.99/0.99)	28,5/28,5 (1.2/1.2)	566438	889633 889637
C-16-3			73,1 (2,87)	26,9/26,9 (1.06/1.06)	28,5/28,5 (1.2/1.2)	566437	889632 889636
C-20-3S	1.625"-12	13,5 (0.53)	76,2 (3.0)	33,3/33,2 (1.31/1.30)	36,4/36,4 (1.43/1.43)	566442	02-113153 02-112969
C-20-3			98,5 (3.87)	33,3/33,2 (1.31/1.30)	36,4/36,4 (1.43/1.43)	566441	889640 889644

Cavity Plugs

C-**-4 Cavity Plugs

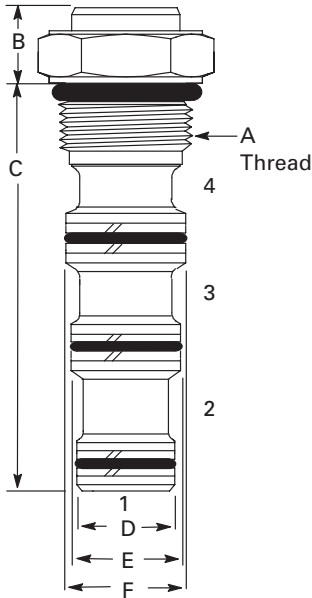

TO FIT CAVITY SIZE	A	B	C	D	ØE	ØF	ØG	ASSY NO.
C-8-4	0.750"-16	22,2 (0.87) hex. Torque 35-40 Nm(25-30 lbf ft)	8,6 (0.34)	54,6 (2,15)	12,6 (0.49)	14,2 (0.55)	15,8 (0.62)	02-171709
C-10-4(U)	0.875"-14	25,4 (1.0) hex. Torque 47-54 Nm (35-40 lbf ft)	7,9 (0.31)	61,9 (2.43)	15,8/15,7 (0.62/0.62)	17,4/17,3 (0.68/0.68)	19,0/18,9 (0.74/0.74)	566244
C-16-4	1.312"-12	38,1 (1.50) hex. Torque 109-122 Nm (80-90 lbf ft)	12,7 (0.50)	101,6 (4.00)	25,3/25,3 (0.99/0.99)	26,9/26,9 (1.06/1.05)	28,5/28,5 (1.12/1.12)	566439
C-20-4	1.625"-12	47,6 (1.87) hex. Torque 129-156 Nm (95-115 lbf ft)	13,5 (0.53)	139,7 (5.50)	31,7/31,6 (1.24/1.24)	33,3/33,2 (1.31/1.30)	36,4/36,4 (1.43/1.43)	566433



IMPORTANT

The cartridges listed are complete with seals compatible with antiwear hydraulic oil. If cartridges are to be compatible with antiwear

and phosphate ester, order cartridges by part number plus the appropriate Viton seal kit as listed in Spare parts. Before using the cartridge, change the seals to Viton.

Special purpose cavity plugs

Functional Symbols

Filter cartridge plugs

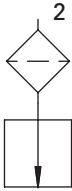

Special 3 way cavity plugs

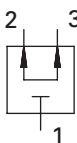
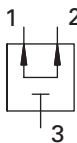

Special 4 way cavity plugs

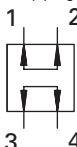

TO FIT CAVITY SIZE	ASSY. NO.	SEAL KIT
C-10-2	02-186758	566806 (Buna-N) 889627 (Viton®)

Screen fitted on cartridge, intended direction of flow is from port 2 to 1 only. Maximum rated flow is 76 L/min (20 USgpm), maximum operating pressure is 350 bar (5000 psi)

TO FIT CAVITY SIZE	ASSY. NO.	SEAL KIT
C-8-3	02-186664	02-160755 (Buna-N) 02-160756 (Viton®)
C-10-3S	02-185257	02-173019 (Buna-N) 02-173020 (Viton®)

TO FIT CAVITY SIZE	ASSY. NO.	SEAL KIT
C-10-3	02-161831	889624 (Buna-N) 889628 (Viton®)

TO FIT CAVITY SIZE	ASSY. NO.	SEAL KIT
C-8-4	02-179151	02-160757 (Buna-N) 02-160758 (Viton®)

Orifice Discs

Blank Orifice Discs (Flat)

Note

For predrilled orifice discs, consult factory.

An orifice disc is installed at the bottom of a standard cavity to create a local pressure drop in the flow to and from port 1 of the cartridge.

Two series of discs are available according to the maximum pressure drop required:

1. Flat discs/maximum pressure drop/13,8 bar (200 psi).
2. Conical discs/maximum pressure drop/210 bar (3000 psi).

CAVITY SIZES	MAX PRESSURE DROP BAR (PSI)	ØA	B	ØC	ASSY NUMBER
C-8-2/4	13,8 (200)	12,45 (0.490)	1,27 (0.050)	*	02-163254
C-10-2/3/4	13,8 (200)	5,80 (0.622) 15,75 (0.620)	1,52 (0.060)	*	02-162850
C-16-2	13,8 (200)	28,58 (1.125) 28,52 (1.123)	2,03 (0.08)	*	02-174507
C-16-3	13,8 (200)	26,97 (1.062) 26,92 (1.060)	2,03 (0.08)	*	–
C-16-3S/4	13,8 (200)	25,4 (1.00) 25,35 (0.998)	2,03 (0.08)	*	–

*User to specify

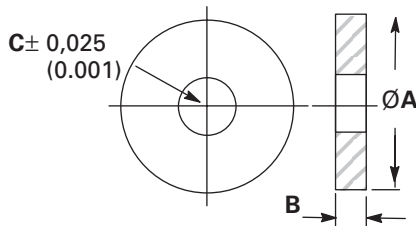

Blank Orifice Discs (Conical)

CAVITY SIZES	MAX PRESSURE DROP BAR (PSI)	ØA	ØB	ØC	D	E	F	ASSY NUMBER
C-8-2/4	210 (3000)	3,96 (0.156)	5,84 (0.230)	12,45 (0.490)	1,90 (0.075)	3,05 (0.120)	–	02-174854
C-8-3	210 (3000)	3,96 (0.156)	5,84 (0.230)	14,05 (0.553)	1,90 (0.075)	3,05 (0.120)	–	02-178181
C-10-2	210 (3000)	5,54 (0.218)	6,35 (0.250)	15,80 (0.622) 15,75 (0.620)	1,14 (0.045)	3,56 (0.140)	–	566478
C-12-2	210 (3000)	7,14 (0.281)	–	23,70 (0.933) 23,65 (0.931)	2,41 (0.095)	3,56 (0.140)	1,14 (0.045)	02-182842

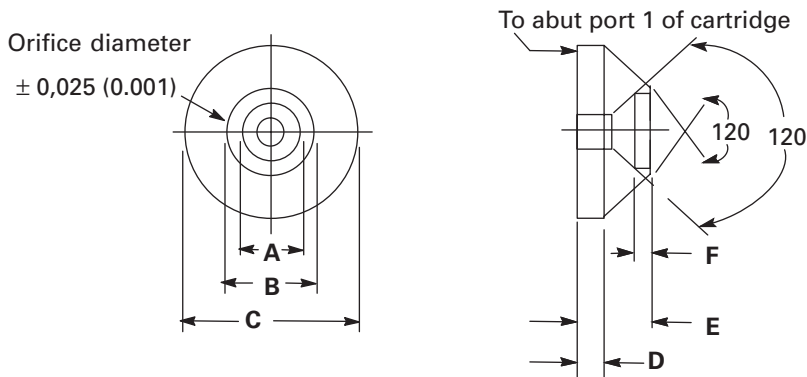

Orifice Disc Sizing Guide (mm)

Select required orifice diameter using the graph below

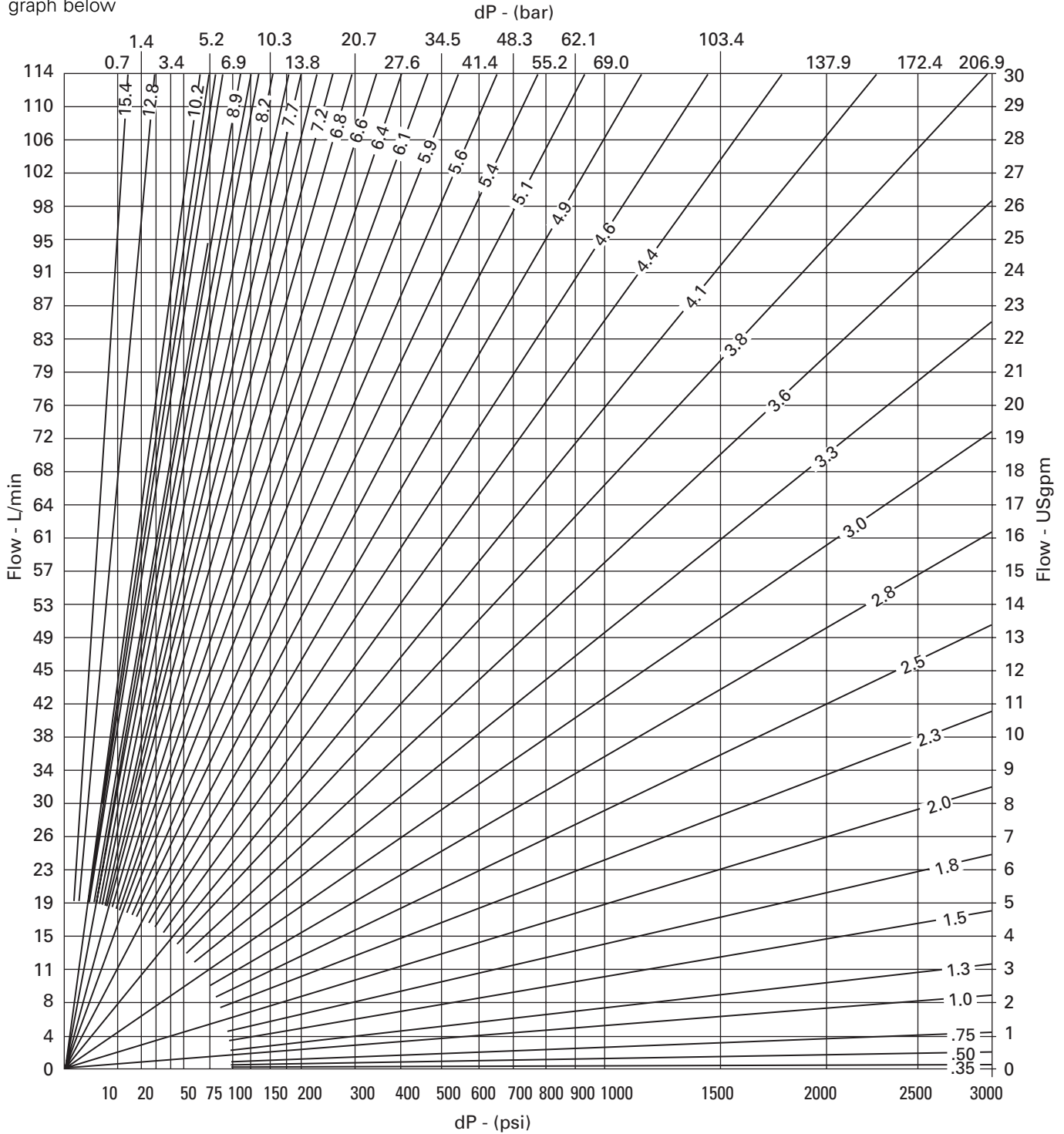

Note
This chart is calculated at 21.8 cSt and 49°C for ISO VG32 fluid (DTE-24), values will change with viscosity changes.

To calculate orifice diameter at other flows and differential pressures use the following formula:
 $D=1.350 \times \sqrt{(Q/\sqrt{dP})}$

where **D**= orifice diameter in millimeters; **Q**= flow in liters per minute; **dP**= differential pressure across orifice in BAR.

Orifice Disc Sizing Guide (inches)

Select required orifice diameter using the graph below

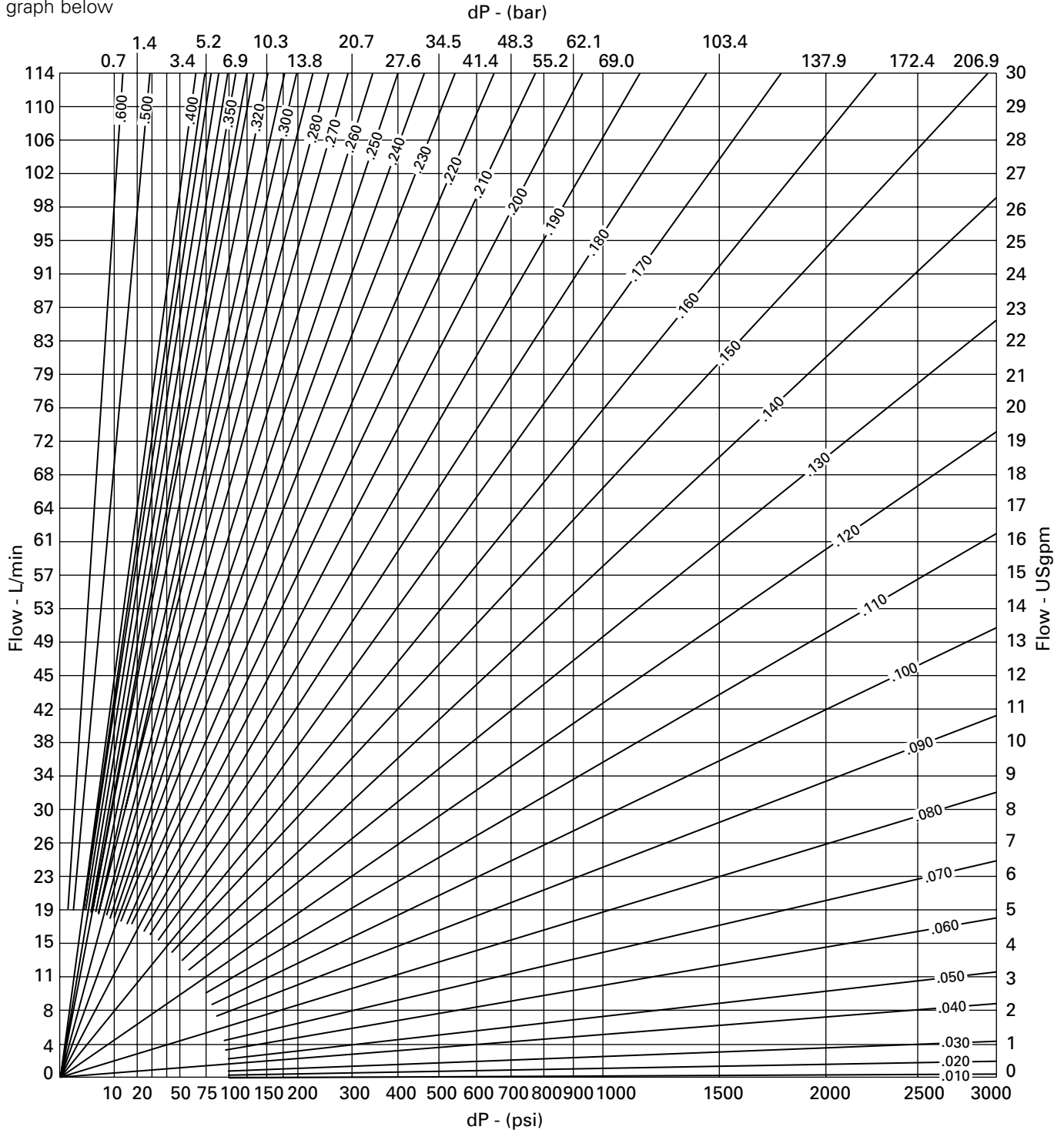

Note
This chart is calculated at 105 SUS and 120°F for ISO VG32 fluid (DTE-24), values will change with viscosity changes.

To calculate orifice diameter at other flows and differential pressures use the following formula:
 $D = 0.203 \times \sqrt{(Q / (\sqrt{dP}))}$

where **D**= orifice diameter in inches; **Q**= flow in US gallons per minute; **dP**= differential pressure across orifice in PSI.

Pilot Pistons

Pilot Piston Assemblies Dimensions

NOMINAL CARTRIDGE SIZE	SINGLE OR DOUBLE ACTING	WITH OR WITHOUT STOPS	A	B	C	REQUIRED HOUSING BORE
8	Single	Without	15,1 (0.60)	34,1 (1.34)	8,3 (0.33)	12,73 (0.500)
	Double	Without	15,1 (0.60)	53,2 (2.10)	8,3 (0.33)	12,75 (0.502)
10	Single	Without	19,1 (0.75)	41,3 (1.63)	13,5 (0.53)	15,88 (0.625)
	Double	Without	19,1 (0.75)	57,2 (2.25)	10,3 (0.41)	15,88 (0.625)
	Single	With	19,1 (0.75)	45,7 (1.80)	6,7 (0.26)	15,90 (0.626)
	Double	With	19,1 (0.75)	54,8 (2.16)	6,7 (0.26)	15,90 (0.626)
12	Single	Without	17,5 (0.69)	44,5 (1.75)	14,3 (0.56)	23,80 (0.937)
	Double	Without	17,5 (0.69)	71,4 (2.81)	14,3 (0.56)	23,85 (0.939)
16	Single	Without	31,8 (1.25)	63,5 (2.50)	12,7 (0.50)	28,58 (1.125)
	Double	Without	31,8 (1.25)	95,3 (3.75)	12,7 (0.50)	28,60 (1.126)
20	Single	Without	38,1 (1.50)	77,8 (3.06)	19,0 (0.75)	36,50 (1.437)
	Double	Without	38,1 (1.50)	117,5 (4.63)	19,0 (0.75)	36,53 (1.438)

Note

Use with cartridges to form pilot operated check and similar functions in MCD and standard valve packages.



WARNING:

The use of pilot pistons with check valve assemblies may increase the load

applied to the valve poppet which may result in reduced fatigue life of the cartridge

Part Numbers

NOMINAL CARTRIDGE SIZE	SINGLE OR DOUBLE ACTING	WITH OR WITHOUT STOPS	PISTON WITH BUNA-N SEALS	PISTON WITH VITON® SEAL	PISTON WITHOUT SEALS
8	Single	Without	02-178662	02-178663	02-178653
	Double	Without	02-178669	02-178670	02-178654
10	Single	Without	02-166275	566418	566417
	Double	Without	566419	566420	02-166313
	Single	With	566421	566422	566337
	Double	With	566423	566424	566338
12	Single	Without	02-185700	02-185701	02-185699
	Double	Without	02-185703	02-185704	02-185702
16	Single	Without	566425	566426	889052
	Double	Without	566428	566429	566427
20	Single	Without	566431	566432	566430
	Double	Without	566434	566435	566433

Forms

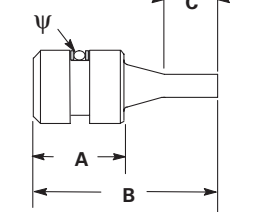

Single-acting, without stop

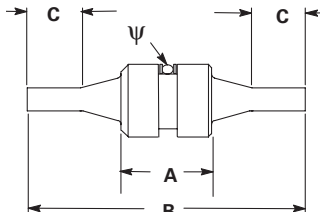

Double-acting, without stop

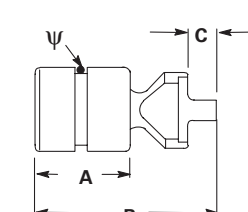

Single-acting, with stop

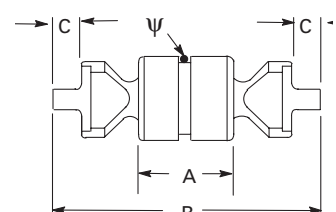

Double-acting, with stop

Note

ψ Sealed models have a central O-ring with a back-up ring on both sides.



WARNING:

Seals should not be used with check valves that have < 50 psi crack pressure

Sensing Check/Panel Mount Adapter

Sensing Check

Sensing check kits can be built into customized manifolds to permit pilot control from two or more alternate sources, as example here:

Kit Part Numbers

SENSE CHECK KIT	PART. NO.
with Buna-N seals	566395
with Viton® seals	566395

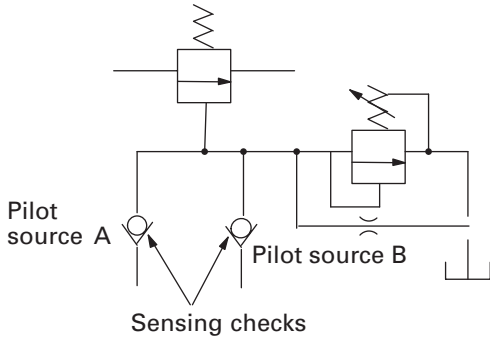

Typical section

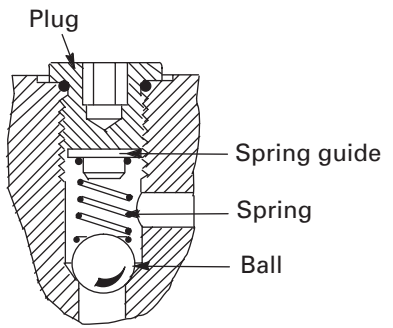

Sensing Check Cavity

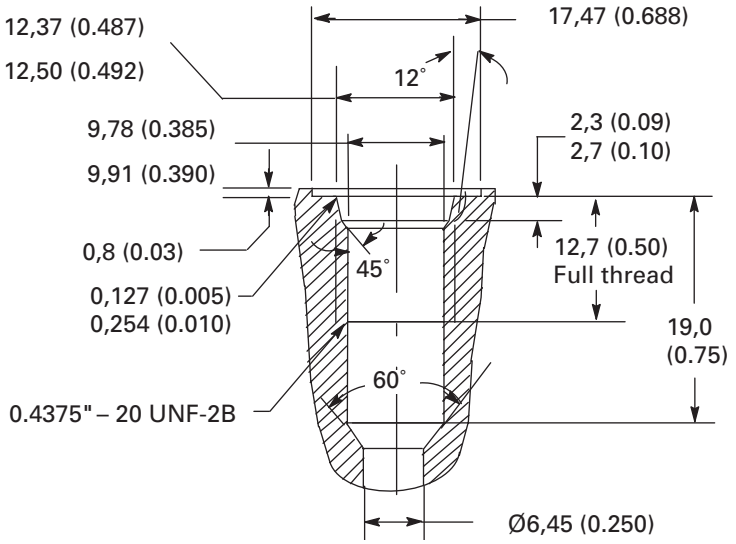

Panel Mount Adapter for 10 & 12 Series Valves

Used for mounting an adjustable pressure valve through a bulkhead or panel surface.

Part Number 02-161837

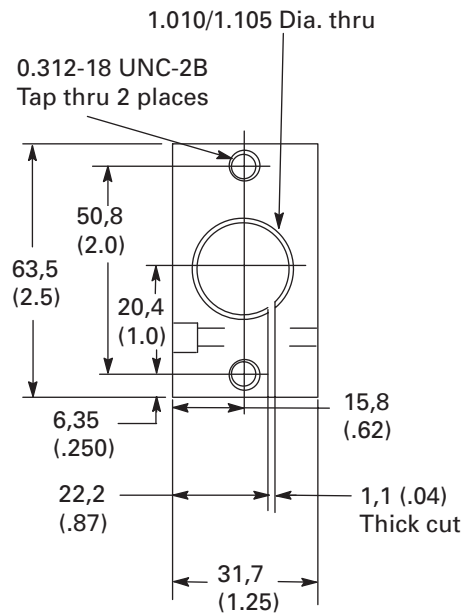
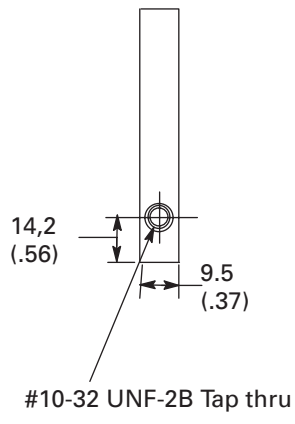
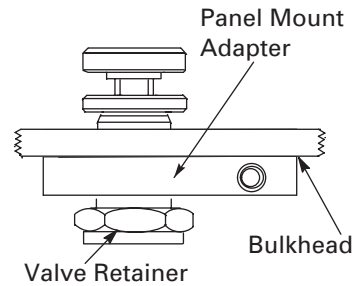

Miscellaneous Parts

Solenoid Valve Parts

Note

When a solenoid valve is ordered as a cartridge only, the nut is included.

DESCRIPTION	PART NUMBER
Nut for standard core tube valves	
8 Series	02-170821
10, 12, 16, 20 Series and SV9-8	565558
10, 12, 16, 20 Series 350 bar valves	02-175698
Coil Spacers	
Spacer for SV9-8	02-186730
Spacer for SV9-10	02-179226
Nut for extended core tube valves	
	565559



Nut for standard core tube valves.



Nut for extended core tube valves.

Spare Parts

SPC1/DPC1/11

Model Code	Check Valve (Qty)	Pilot Piston (QTY)	Buna-N Seal Kit	Viton® Seal Kit
SPC1-10-P	CV1-10(V)-P-0-15 (1)	566417 (1)	565803	566086
SPC1-16-P	CV1-16(V)-P-0-20 (1)	889052 (1)	565810	889609
SPC1-20-P	CV2-20(V)-P-0-15 (1)	566430 (1)	889615	889619
DPC1-10-P	CV1-10(V)-P-0-15 (2)	02-166313 (1)	565803	566086
DPC11-12-P	CV11-12(V)-P-0-15 (2)	02-185702 (1)	02-165889	02-165888
DPC1-16-P	CV1-16(V)-P-0-20 (2)	566427 (1)	565810	889609
DPC1-20-P	CV2-20(V)-P-0-15 (2)	566433 (1)	889615	889619

MCV

Model Code	Check Valve	(Qty)	Relief Valve	(Qty)	Piston	(Qty)
MCV1-16	CV1-16-P-0-5	(1)	RV3-16-S-0-35/	(1)	889052	(1)
MCV4-16	CV1-16-P-0-5	(4)	RV3-16-S-0-35/	(2)	889052	(2)
MCV1-20	CV2-20-P-0-5	(1)	RV3-16-S-0-35/	(1)	889052	(1)
MCV2-20	CV2-20-P-0-5	(2)	RV3-16-S-0-35/	(2)	889052	(2)

Adjustment Kits

CBV1/2 & VCB1 SERIES

Type	Part Number Size 10	Part Number Size 12
S (nut)	02-163513	02-170161
C (cap)	02-163514	02-170163
K (knob)	02-170164	02-170164

NV1 8-SERIES

Description	Part Number
C (Cap kit):	02-170163
Cap	02-170163
Nut	02-170161
K (Knob kit)	02-171892
Knob	02-174439
Jam nut	02-174515
Set screw	001016
S Kit:	
Nut	02-170159

MCV SERIES KNOB KIT

Description	Part Number
K (Knob kit):	565586
Knob	02-162137*
Jam nut	02-170637*
Set screw	000805*
S (nut)	565558

* Supplied as part of kit 565586

PFR2-16 SERIES KNOB KIT

Description	Part Number
K (Knob kit)	565586
Knob	02-162137
Jam nut	02-170637
Set screw	000805

FCV7,FCV6,FR2, SERIES KNOB KIT

Description	Part Number
K (Knob kit)	565585
Knob	02-165873*
Jam nut	02-170635*
Set screw	001016*

* Supplied as part of kit 565585

J

Adjustment Kits (cont.)

Adjustment Kits

(cont.)

Note

The only difference between the "D/B" and the "L/E" adjustment option is the orientation of the detent plate.

The B/E options are not available in kit form. The only difference between these and the D/L versions is that the lever is replaced with 02-165925 and an additional 310204 set screw is required.

NV1 10-SERIES	PART NUMBER
Knob	888963
Acorn nut	02-162993
Nameplate	02-165920

NV1 16-&20-SERIES	PART NUMBER
Knob	02-162130
Acorn nut	02-162992
Nameplate(attached)	02-165922

FAR1-10/12 & 16 SERIES	PART NUMBER
Knob kit	02-185169

MRV2-10-D/L, B/E 10-SERIES	PART NUMBER
Lever kit:	565610
Hub	02-169085
Lever	888980
Spring	888986
Plunger	02-163705
Insert	02-169956
Spring	888874
Detent pla.	888983
Plate supp.	02-165090
Nameplate	888964
Acorn nut	02-162993

MRV2-10-K 10-SERIES	PART NUMBER
Knob	888963
Acorn nut	02-162993
Nameplate	888964

MRV2-10-D/L, 10-SERIES	PART NUMBER
Lever kit:	565611
Hub	02-169453
Lever	888988
Spring	888986
Plunger	02-163705
Insert	02-170103
Spring	888993
Detent plate	02-170102
Plate supp.	02-161901
Nameplate	02-165922
Acorn nut	02-162992

MRV2-16-K 16-SERIES	PART NUMBER
Knob	02-162130
Acorn nut	02-162992
Nameplate	888967

PRESSURE CONTROL, 8-SERIES	PART NUMBER
Retaining ring	02-166712
K (Knob kit)	02-170164
Cap	02-162806
Nut	02-170159

Retaining ring is required for C and S controls. When converting from the "S" or "C" option to the "K" option, remove retaining ring and nut before installing the knob kit.

PRESSURE CONTROL, 10 & 12-SERIES	PART NUMBER
C (Cap)	02-170616*
S (Nut)	565558*
K (Knob kit)	565585
Knob	02-165873
Jam nut	02-160635
Set screw	001016

*These parts also used to service PUV3-10 models.

PRESSURE CONTROL, 16-SERIES	PART NUMBER
S (Nut)	565558
RV3 K (Knob kit)	565586
Knob	02-162137
Jam nut	02-170637
Set screw	000805
RV5 K (Knob Kit)	565585
Knob	02-165873
Jam nut	02-160635
Set screw	001016
RV5 C (Cap)	02-170616

Seal Kits

MODEL	BUNA-N SEAL KIT	VITON® SEAL KIT
ADV1-16	565812	889611
CBV1/2-10	02-173019	02-173020
CBV1/2-12	02-180095	02-165887
CV1-10	565803	566086
CV1-16/CV6-16	565810	889609
CV11-12	02-165889	02-165888
CV16-10	565803	566086
CV2-20	889615	889619
CV3-10/CV6-10	565803	566086
CV3-8	02-165875	02-165877
CV3-4	9900174-000	9900175-000
DPC1-10	889656	02-173599
DPC1-16	889644	02-173598
DPC1-20	889656	02-173599
DPS2-10	889650	889652
DPS2-16	889659	02-165871
DPS2-20	02-113153	02-112969
DSV1-10	565804	889599
DSV2-4	9900176-000	9900177-000
DSV2-8	02-160755	02-166756
DSV3-12	154131	396102
DSV3-16	154132	396105
DSV3-6	154128	396096
DSV3-8	154129	396098
DSV4-10	889597	02-172397
DSV4-16	889634	889638
EFV1-12	9900171-000	9900172-000
EPRV1-10	565804	889599
EPRV1-16	889634	889638
EPRV2-8	02-178451	02-178452
EPV10	02-317580	—
EPV16	02-154069	—
ERV1-10	565803	565086
ERV1-16	565810	889609
ERV2-10	565803	565086
FAR1-10	565803	565086
FAR1-12	02-181304	02-181305
FCV11-12	02-165889	02-165888
FCV6-16	889631	889635
FCV7-10	565806	889627
FDC1-10	889625	566080
FDC1-16	889634	889638
FDC1-20	889639	889643

MODEL	BUNA-N SEAL KIT	VITON® SEAL KIT
FDC3-10	889625	566080
FDC3-16	889634	889638
FDC3-20	889639	889643
FR1-16	565810	880609
FR1-20	889615	889619
FR2-10	565803	566086
FR2-16	565810	889609
FR5-8	02-165875	02-165877
FR5-10	565803	566086
MCV1-16	565810	889609
MCV1-20	Check 889615 Relief 565810	889619 889609
MCV2-20	Check 889615 Relief 565810	889619 889609
MCV4-16	565810	889609
MPV1-10	565803	566086
MRV2-10	561810	889609
MRV2-16	561810	889609
MRV3-10	565804	889599
MRV3-16	889632	889636
MRV4-10	565805	889600
MRV4-16	889634	889638
MRV5-10	889625	566080
MRV5-16	889634	889638
MRV6-10	889625	566080
NV1-10	565806	889627
NV1-16	565810	889609
NV1-20	889615	889619
NV1-8	02-165875	02-165877
PCS3-10	565812	889611
PCS3-16	565811	889610
PCS3-20	889616	02-175433
PCS4-10	889651	889653
PCS3-20	889616	02-175433
PCS4-10	889651	889653
PCS4-10	889651	889653
PCS3-20	889616	02-175433
PCS4-10	889651	889653
PCS4-16	889660	02-175435
PCS4-20	889660	02-175435
PFR1-16	565811	889610
PFR2-10	565804	889599
PFR2-16	565811	889610
PFR5-8	02-173427	02-173434

Seal Kits (cont.)

MODEL	BUNA-N SEAL KIT	VITON® SEAL KIT
PFR5-10	565804	889599
PFRD/S-12	2022914-921 (Urethane)	—
PFRD/S-16	2022915-922 (Urethane)	—
PFRD/S-20	02-187543 (Urethane)	—
POC1-10	889650	889652
POC2-10	2185020	2184785
POC1-12	02-180095	02-165887
POC2-12	02-185211	02-185212
PRV1-10	565804	889599
PRV11-12	02-180095	02-165887
PRV12-10	565804	889599
PRV12-12	02-165872	02-165886
PRV2-10	565804	889599
PRV2-16	565811	889610
PSV1-10	565804	889599
PSV1-16	565811	889610
PSV10-10	889625	566080
PSV11-12	02-180095	02-165887
PSV2-10	565804	889599
PSV2-8	02-160755	02-160756
PSV3-10	565804	889599
PSV4-10	565804	889599
PSV4-8	02-160755	02-160756
PSV5-10	565804	889599
PSV7-10	565804	889599
PSV8-10	889625	566080
PTS1-10	889625	566080
PTS1-16	889634	889638
PTS1-20	565916	889646
PTS2-10	889625	566080
PTS2-16	889634	889638
PTS2-20	565916	889646
PTS3-10	889625	566080
PTS3-16	889634	889638
PTS3-20	565916	889646
PTS4-16	889634	889638
PTS5-10	889624	889628
PTS5-16	889634	889638
PTS6-10	889625	566080
PTS6-16	889634	889638
PTS7-10	889624	889628
PUV3-10	565804	889599

MODEL	BUNA-N SEAL KIT	VITON® SEAL KIT
PTS9-12	202914-921(Urethane)	—
PTS9-16	202915-922(Urethane)	—
PTS9-20	02-187543 (Urethane)	—
RCV3-10	565803	566086
RV1-10	565803	566086
RV1-8	02-165875	02-165877
RV10-10	565803	566086
RV11-12	02-165889	02-165888
RV2-10	565803	566086
RV3-10	565803	566086
RV3-16	565810	889609
RV3A-10	565806	889627
RV4-10	565803	566086
RV5-10	565803	566086
RV5-16	889631	889635
RV5A-10	565806	889627
RV6-10	565803	566086
RV8-10	565803	566086
RV8-8	02-165875	02-165877
RV8A-10	565806	889627
SBV11-8-C	02-160777	02-160778
SBV12-8-C	02-160777	02-160778
SBV11-10-C	565806	889627
SBV11-12-C	02-165889	02-165888
SBV11-8-O	02-160777	02-160778
SBV11-10-O	565806	889627
SBV11-12-O	02-165889	02-165888
SPC1-10	889648	889649
SPC1-16	889644	02-173598
SPC1-20	889656	02-173599
SPC2-10-P	02-153267	02-173666
SPC2-8-P	02-173326	02-173327
SV1-8-3/3M	02-160755	02-160756
SV1-8-4/4M	02-160757	02-160758
SV1-10-3/3M/3R	565804	889599
SV1-10-4/4M/4R	565805	889600
SV1-10-C/CM/CR	565803	566086
SV1-16-C/CM/CR	565810	889609
SV2-10-4/4M/4R	565805	889600
SV2-10-C/CM/CR	565803	566086
SV2-8-4/4M	02-160757	02-160758
SV2-20-C/CM/CR	889615	889619

Seal Kits (cont.)

MODEL	BUNA-N SEAL KIT	VITON® SEAL KIT
SV3-10-C/CM/CR	565803	566086
SV3-10-O/OP/OS	565803	566086
SV3-10-4/4M/4R	565805	889600
SV3-12-C/CM/CR	02-165889	02-165888
SV3-12-O/OP/OS	02-165889	02-165888
SV3-16-O/OP/OS	565810	889609
SV3-20-O/OP/OS	889615	889619
SV4-8-C/CM	02-160777	02-160778
SV4-8-O/OM	02-160777	02-160778
SV4-8-3/3M	02-160755	02-160756
SV4-10-C/CM/CR	565806	889627
SV4-10-O/OM/OR	565806	889627
SV4-10-3/3P/3S	565804	889599
SV4-10-4/4M/4R	565805	889600
SV5-8-C/CM	02-165875	02-165877
SV5-8-O/OP/OS	02-165875	02-165877
SV5-10-O/OP/OS	565803	566086
SV5-10-4/4M/4R	565805	889600
SV7-10-4/4P/4S	565805	889600
SV9-8 (all)	02-160757	02-160758
SV9-10 (all)	889625	566080
SV11-8-3/3M	02-160755	02-160756
SV11-8-4/4M	02-160757	02-160758
SV11-10-C/CM	565803	566086
SV11-10-3/3M	565804	889599

MODEL	BUNA-N SEAL KIT	VITON® SEAL KIT
SV11-10-4/4M	565805	889600
SV12-8-4/4M	02-160757	02-160758
SV12-10-C/CM	565803	566086
SV13-10-C/CM	565803	566086
SV13-10-O/OP/OS	565803	566086
SV13-12-C/CM	02-165889	02-165888
SV13-12-O/OP/OS	02-165889	02-165888
SV13-16-C/CM	565810	889609
SV13-16-O/OP/OS	565810	889609
SV13-20-C/CM	889615	889619
SV13-20-O/OP/OS	889615	889619
SV14-8-C/CM	02-165875	02-165877
SV14-8-O/OM	02-165875	02-165877
SV14-10-C/CM	565806	889627
SV14-10-O/OM	565806	889627
SV15-8-C/CM	02-165875	02-165877
SV15-8-O/OP/OS	02-165875	02-165877
SV15-10-O/OP/OS	565803	566086
VCB*-10	889625	566080
VCB*-12	02-160979	02-160980
VF1-10	565803	566086
VF1-16	565810	889609
VF1-20	889615	889619
VRV11-12	02-180095	02-165887

Алматы (7273)495-231
 Ангарск (3955)60-70-56
 Архангельск (8182)63-90-72
 Астрахань (8512)99-46-04
 Барнаул (3852)73-04-60
 Белгород (4722)40-23-64
 Благовещенск (4162)22-76-07
 Брянск (4832)59-03-52
 Владивосток (423)249-28-31
 Владикавказ (8672)28-90-48
 Владимир (4922)49-43-18
 Волгоград (844)278-03-48
 Вологда (8172)26-41-59
 Воронеж (473)204-51-73
 Екатеринбург (343)384-55-89

Иваново (4932)77-34-06
 Ижевск (3412)26-03-58
 Иркутск (395)279-98-46
 Казань (843)206-01-48
 Калининград (4012)72-03-81
 Калуга (4842)92-23-67
 Кемерово (3842)65-04-62
 Киров (8332)68-02-04
 Коломна (4966)23-41-49
 Кострома (4942)77-07-48
 Краснодар (861)203-40-90
 Красноярск (391)204-63-61
 Курск (4712)77-13-04
 Курган (3522)50-90-47
 Липецк (4742)52-20-81

Магнитогорск (3519)55-03-13
 Москва (495)268-04-70
 Мурманск (8152)59-64-93
 Набережные Челны (8552)20-53-41
 Нижний Новгород (831)429-08-12
 Новокузнецк (3843)20-46-81
 Ноябрьск (3496)41-32-12
 Новосибирск (383)227-86-73
 Омск (3812)21-46-40
 Орел (4862)44-53-42
 Оренбург (3532)37-68-04
 Пенза (8412)22-31-16
 Петрозаводск (8142)55-98-37
 Псков (8112)59-10-37
 Пермь (342)205-81-47

Ростов-на-Дону (863)308-18-15
 Рязань (4912)46-61-64
 Самара (846)206-03-16
 Санкт-Петербург (812)309-46-40
 Саратов (845)249-38-78
 Севастополь (8692)22-31-93
 Саранск (8342)22-96-24
 Симферополь (3652)67-13-56
 Смоленск (4812)29-41-54
 Сочи (862)225-72-31
 Ставрополь (8652)20-65-13
 Сургут (3462)77-98-35
 Сыктывкар (8212)25-95-17
 Тамбов (4752)50-40-97
 Тверь (4822)63-31-35

Тольятти (8482)63-91-07
 Томск (3822)98-41-53
 Тула (4872)33-79-87
 Тюмень (3452)66-21-18
 Ульяновск (8422)24-23-59
 Улан-Удэ (3012)59-97-51
 Уфа (347)229-48-12
 Хабаровск (4212)92-98-04
 Чебоксары (8352)28-53-07
 Челябинск (351)202-03-61
 Череповец (8202)49-02-64
 Чита (3022)38-34-83
 Якутск (4112)23-90-97
 Ярославль (4852)69-52-93

Россия +7(495)268-04-70

Казахстан +7(7172)727-132

Киргизия +996(312)96-26-47

<https://vickers.nt-rt.ru> || vsh@nt-rt.ru

