

Алматы (7273)495-231
Ангарск (3955)60-70-56
Архангельск (8182)63-90-72
Астрахань (8512)99-46-04
Барнаул (3852)73-04-60
Белгород (4722)40-23-64
Благовещенск (4162)22-76-07
Брянск (4832)59-03-52
Владивосток (423)249-28-31
Владикавказ (8672)28-90-48
Владимир (4922)49-43-18
Волгоград (844)278-03-48
Вологда (8172)26-41-59
Воронеж (473)204-51-73
Екатеринбург (343)384-55-89

Иваново (4932)77-34-06
Ижевск (3412)26-03-58
Иркутск (395)279-98-46
Казань (843)206-01-48
Калининград (4012)72-03-81
Калуга (4842)92-23-67
Кемерово (3842)65-04-62
Киров (8332)68-02-04
Коломна (4966)23-41-49
Кострома (4942)77-07-48
Краснодар (861)203-40-90
Красноярск (391)204-63-61
Курск (4712)77-13-04
Курган (3522)50-90-47
Липецк (4742)52-20-81

Магнитогорск (3519)55-03-13
Москва (495)268-04-70
Мурманск (8152)59-64-93
Набережные Челны (8552)20-53-41
Нижний Новгород (831)429-08-12
Новокузнецк (3843)20-46-81
Ноябрьск (3496)41-32-12
Новосибирск (383)227-86-73
Омск (3812)21-46-40
Орел (4862)44-53-42
Оренбург (3532)37-68-04
Пенза (8412)22-31-16
Петрозаводск (8142)55-98-37
Псков (8112)59-10-37
Пермь (342)205-81-47

Ростов-на-Дону (863)308-18-15
Рязань (4912)46-61-64
Самара (846)206-03-16
Санкт-Петербург (812)309-46-40
Саратов (845)249-38-78
Севастополь (8692)22-31-93
Саранск (8342)22-96-24
Симферополь (3652)67-13-56
Смоленск (4812)29-41-54
Сочи (862)225-72-31
Ставрополь (8652)20-65-13
Сургут (3462)77-98-35
Сыктывкар (8212)25-95-17
Тамбов (4752)50-40-97
Тверь (4822)63-31-35

Тольятти (8482)63-91-07
Томск (3822)98-41-53
Тула (4872)33-79-87
Тюмень (3452)66-21-18
Ульяновск (8422)24-23-59
Улан-Удэ (3012)59-97-51
Уфа (347)229-48-12
Хабаровск (4212)92-98-04
Чебоксары (8352)28-53-07
Челябинск (351)202-03-61
Череповец (8202)49-02-64
Чита (3022)38-34-83
Якутск (4112)23-90-97
Ярославль (4852)69-52-93

Россия +7(495)268-04-70

Казахстан +7(7172)727-132

Киргизия +996(312)96-26-47

<https://vickers.nt-rt.ru> || vsh@nt-rt.ru

OFF, OFMT and OFRT Pressure and Return Line Filters



VICKERS®

Introduction

Description

OFP filters are designed for pressure line applications and are suitable for in-line installation. OFMT filters are designed for return lines and are installed semi-immersed in a reservoir. OFRT filters are also designed for return lines and are installed semi-immersed or totally immersed in a reservoir. All remove particulate contaminants from the fluid, thus improving performance and reliability of system components while extending their service life.

Vickers provides a variety of options to implement contamination control in hydraulic systems.

To achieve target cleanliness levels, filters are available with a wide range of:

- Element choices
- Port sizes
- Bypass valves
- ΔP indicators

Filters are thoroughly multipass tested (ISO 4572, $\beta \geq 200$) and rated to achieve cleanliness levels in accordance with ISO 4406. For assistance in selecting a target cleanliness level, consult American National Standard Institute ANSI (NFPA/JIC) T2.24.1-1991 or your local Vickers representative.

Features and Benefits

- High efficiency filter elements with superior dirt-holding capacity.
- Excellent pressure drop characteristics.
- ΔP indicator options for flexibility in system design.
- Bowl length options for design flexibility.
- Easy element changes.
- Bypass valve prevents excessive pressure drop and prevents element collapse and release of retained contaminants back into hydraulic system.
- Designed to comply with ISO standards.

Contents

OFP Pressure Line Filters (420 bar & 450 L/min max.)

- Filter Model Codes 4
- Replacement Element Model Codes 5
- Specifications 6
- OFP065 Selection and Installation 7
- OFP135 Selection and Installation 8
- OFP320/321 Selection and Installation 9
- OFP325 Selection and Installation 11
- Pressure Drop, “N” Elements (20 bar collapse pressure) 13
- Pressure Drop, “H” Elements (210 bar collapse pressure) 14

OFMT Return Line Filters (7 bar & 150 L/min max.)

- Filter Model Codes 15
- Replacement Element Model Codes 15
- Specifications 16
- OFMT020 Selection and Installation 17
- OFMT100 Selection and Installation 18
- Pressure Drop, “N” Elements (3 bar collapse pressure) 19
- Pressure Drop, “H” Elements (10 bar collapse pressure) 19

OFRT Return Line Filters (10 bar & 2000 L/min max.)

- Filter Model Codes 20
- Replacement Element Model Codes 21
- Specifications 21
- OFRT100 Selection and Installation 22
- OFRT250 Selection and Installation 24
- OFRT630 Selection and Installation 26
- OFRT850 Selection and Installation 28
- Element and Machining Dimensions 30
- Pressure Drop, “A” (glass microfiber) Elements 31
- Pressure Drop, “P” (resin-impregnated paper) Elements 33

Contamination Control 35

OFP Filter Model Codes

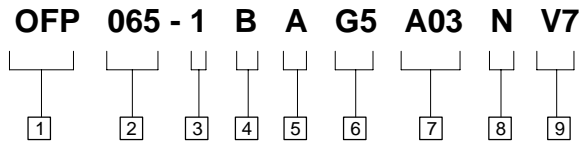

1 Filter series

OFP – Pressure line filter

2 Nominal filter size

065

135

320

321

325

3 Bowl length

OFP065 = 1, 2, 3

OFP135 = 1, 2

OFP320 = 1, 2, 3, 4

OFP321 = 1, 2, 3, 4

OFP325 = 1, 2, 3, 4

4 Integral bypass valve

S – Without bypass valve

B – With bypass valve

5 Seals

A – Nitrile (Buna-N)

V – Viton†

† Viton is a registered trade mark of E. I. DuPont

6 Port options

Ports code*	Nominal filter size				
	065	135	320	321	325
G1	1/2" BSP	3/4" BSP	1-1/4" BSP	1-1/4" BSP	–
G2	3/4" BSP	1" BSP	1-1/2" BSP	1-1/2" BSP	–
G3	1/2" NPT	3/4" NPT	1-1/4" NPT	1-1/4" NPT	–
G4	3/4" NPT	1" NPT	1-1/2" NPT	1-1/2" NPT	–
G5	SAE 8	SAE 12	SAE 20	SAE 20	–
G6	SAE 12	SAE 16	SAE 24	SAE 24	–
F1	–	3/4" SAE/M 3000 psi	1-1/4" SAE/M 3000 psi	–	2" SAE/M 3000 psi
F2	–	1" SAE/M 3000 psi	1-1/2" SAE/M 3000 psi	–	2" SAE/UNC 3000 psi
F3	–	3/4" SAE/UNC 3000 psi	1-1/4" SAE/UNC 3000 psi	–	–
F4	–	1" SAE/UNC 3000 psi	1-1/2" SAE/UNC 3000 psi	–	–
F5	–	3/4" SAE/M 6000 psi	1-1/4" SAE/M 6000 psi	–	2" SAE/M 6000 psi
F6	–	3/4" SAE/UNC 6000 psi	1-1/4" SAE/UNC 6000 psi	–	2" SAE/UNC 6000 psi

* G codes are for thread connections. F codes are for flange connections with metric or inch bolt holes.

7 Element micron rating

A03 – 3 micron

A06 – 6 micron

A10 – 10 micron

A25 – 25 micron

X – Housing only

8 Element series (collapse pressure)

N – 20 bar (300 psi)

H – 210 bar (3000 psi)

– Omit for housing only

9 Element condition indicator

T2 – With plug (no indicator)

V7 – Visual, 5 bar (75 psi)

K71

K72 – Visual, electrical

K73 – 5 bar (75 psi)

71 = 24 Vdc

72 = 115 Vac

73 = 230 Vac

N7 – Electrical, 5 bar (75 psi)

OFP Replacement Element Model Codes

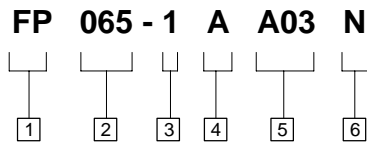

1 Element series

FP – Element for pressure line filter

2 Nominal filter size

065
135
320

3 Filter bowl length

OFP065 = **1, 2, 3**
OFP135 = **1, 2**
OFP320 = **1, 2, 3, 4**

4 Seals

A – Nitrile (Buna-N)
V – Viton

5 Micron rating

A03 – 3 micron
A06 – 6 micron
A10 – 10 micron
A25 – 25 micron

6 Element collapse pressure

N – 20 bar (300 psi)
H – 210 bar (3000 psi)

Note: FP320 elements are used in the OFP320, OFP321 and OFP325 housings.

OFF Specifications

Flow rate

OFF065: See page 7.
 OFF135: See page 8.
 OFF320/321: See page 10.
 OFF325: See page 12.

Element collapse pressure

N element: 20 bar (300 psi)
 H element: 210 bar (3000 psi)

Filter body

Max. pressure: 420 bar (6090 psi)
 Test pressure: 630 bar (9135 psi)
 Min. burst press: 1250 bar (18,125 psi)
 Fatigue test: Body subjected to pressure impulses from 0 to 420 bar (0 to 6090 psi) will withstand one million cycles.

Material

Head: Cast iron
 Bowl: Steel
 Element media: Glass microfiber
 Seals: Nitrile (Buna-N)
 Viton

Housing and element fluid compatibility

Compatible with most petroleum oil, water glycol, oil-in-water and water-in-oil fluids. Optional seals available for phosphate esters.

Optional bypass valve

Valve starts to open when pressure drop across filter element exceeds 6 bar (90 psi) due to flow surges, high viscosity oil, clogged element, or a combination of these factors.

Micron rating

A03 code: 3 micron
 A06 code: 6 micron
 A10 code: 10 micron

Temperature range

- 25 °C to +110 °C
 (- 13 °F to +230 °F)

Dry weight (approximate)

OFF065: See page 7.
 OFF135: See page 8.
 OFF320/321: See page 10.
 OFF325: See page 12.

Element condition indicators

Indicator differential pressure setting:
 5 bar (75 psi) ± 10%.

K7 & N7 INDICATORS

Max. voltage: 220 Vac 50 to 60 Hz
 Max. current: 0.5 A resistive
 0.25 A inductive

Switching power: 100 VA

CONNECTOR DIN 43650 (K7 and N7 indicators)

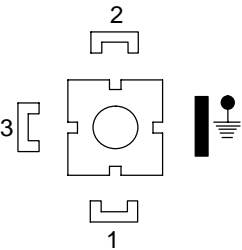

ELECTRICAL CONNECTION (N7 indicator)

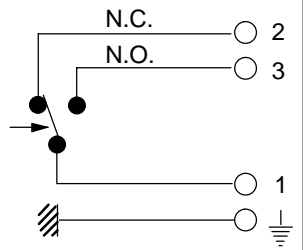

Supply voltage (V)	K7 series indicator (visual-electrical)		N7 series indicator (electrical)	
	Resistive load (A)	Inductive load (A)	Resistive load (A)	Inductive load (A)
120 Vac	5	5	5	2
250 Vac	5	5	5	2
30 Vdc	5	5	5	3
50 Vdc	-	-	1	1
75 Vdc	-	-	0,75	0,75
125 Vdc	-	-	0,5	0,03
250 Vdc	-	-	0,25	0,03

ELECTRICAL CONNECTION (K7 indicator)

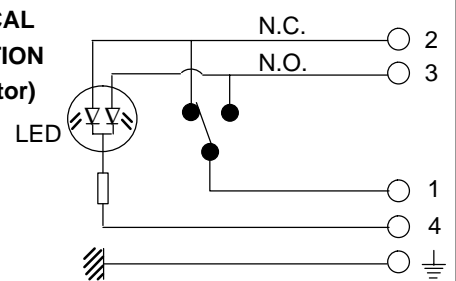

VISUAL V7 SERIES

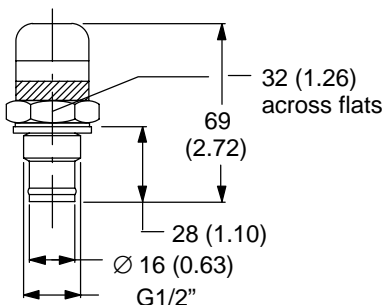

ELECTRICAL N7 SERIES

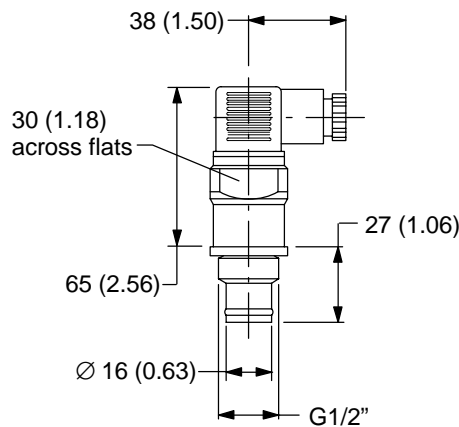

VISUAL-ELECTRICAL K7 SERIES

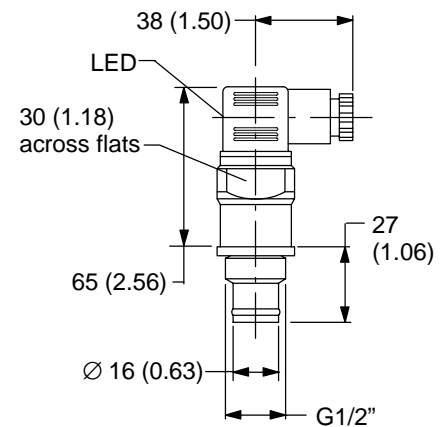

OFP065 Selection & Installation

Dimensions in mm (inch)

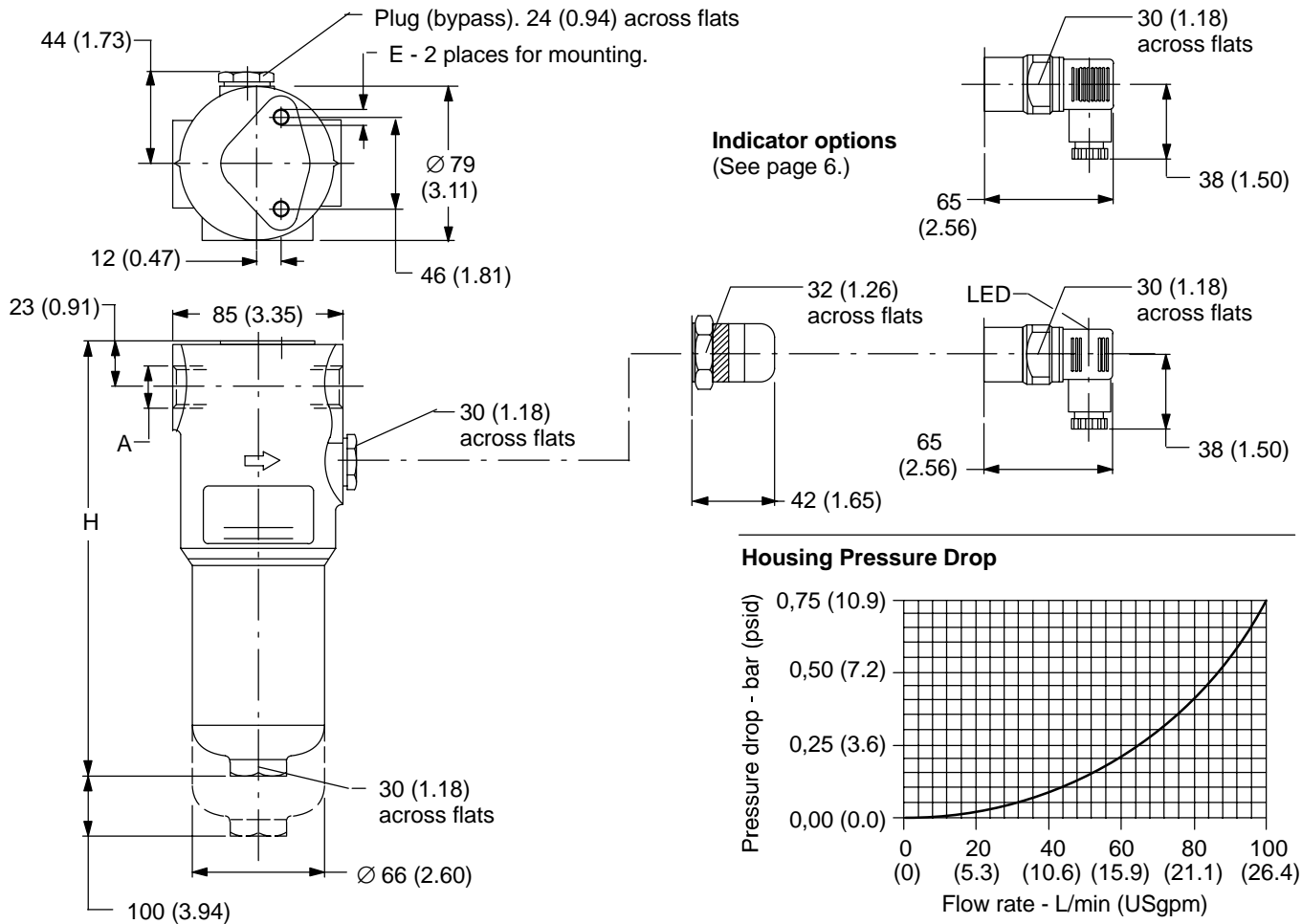

The following sizing recommendations are based on using mineral oil at 30 mm²/s (cSt) viscosity, maximum housing pressure drop 0,4 bar (6 psi), maximum clean element pressure drop 0,8 bar (12 psi). Refer to individual pressure drop curves, pages 13 and 14, to obtain filter assembly pressure drop information ($\Delta P_{\text{Total}} = \Delta P_{\text{Housing}} + \Delta P_{\text{Element}}$).

Micron code	Flow rate L/min (USgpm)		Bowl length code	H dim.	Port size BSP NPT SAE	Weight with element kg (lb)
	N element	H element				
A03	18 (4.8)	15 (4.0)	1	200 (7.87)	1/2"	3,9 (8.60)
A06	20 (5.3)	18 (4.8)				
A10	35 (9.2)	32 (8.5)				
A25	50 (13.2)	48 (12.7)				
A03	22 (5.8)	18 (4.8)	2	230 (9.06)	1/2"	4,2 (9.30)
A06	35 (9.2)	25 (6.6)				
A10	50 (13.2)	43 (11.4)				
A25	75 (19.8)	65 (17.2)				
A03	35 (9.2)	30 (7.9)	3	330 (12.99)	3/4"	5,7 (12.57)
A06	60 (15.9)	50 (13.2)				
A10	75 (19.8)	65 (17.2)				
A25	90 (23.8)	80 (21.1)				

Housing Pressure Drop

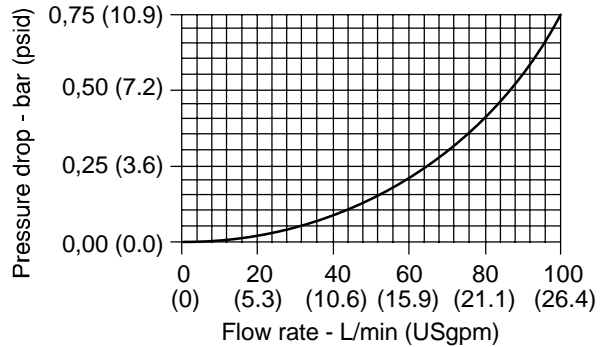

Bypass Valve Pressure Drop

Based on mineral oil with density of 0,86 kg/dm³. ΔP varies proportionally to density.

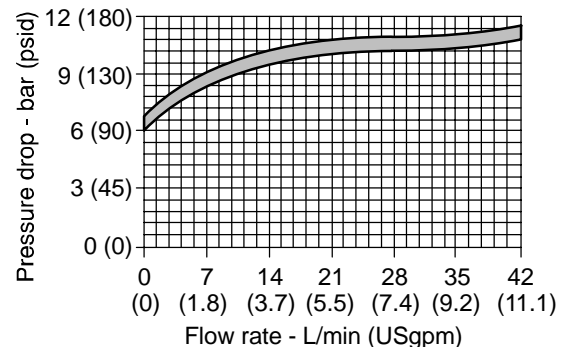

Ports code	Thread connections	
	A	E
G1	1/2" BSP	M8
G2	3/4" BSP	M8
G3	1/2" NPT	5/16" UNC
G4	3/4" NPT	5/16" UNC
G5	SAE 8 - 3/4" - 16 UNF	5/16" UNC
G6	SAE 12 - 1 1/16" - 12 UN	5/16" UNC

OFP135 Selection & Installation

Dimensions in mm (inch)

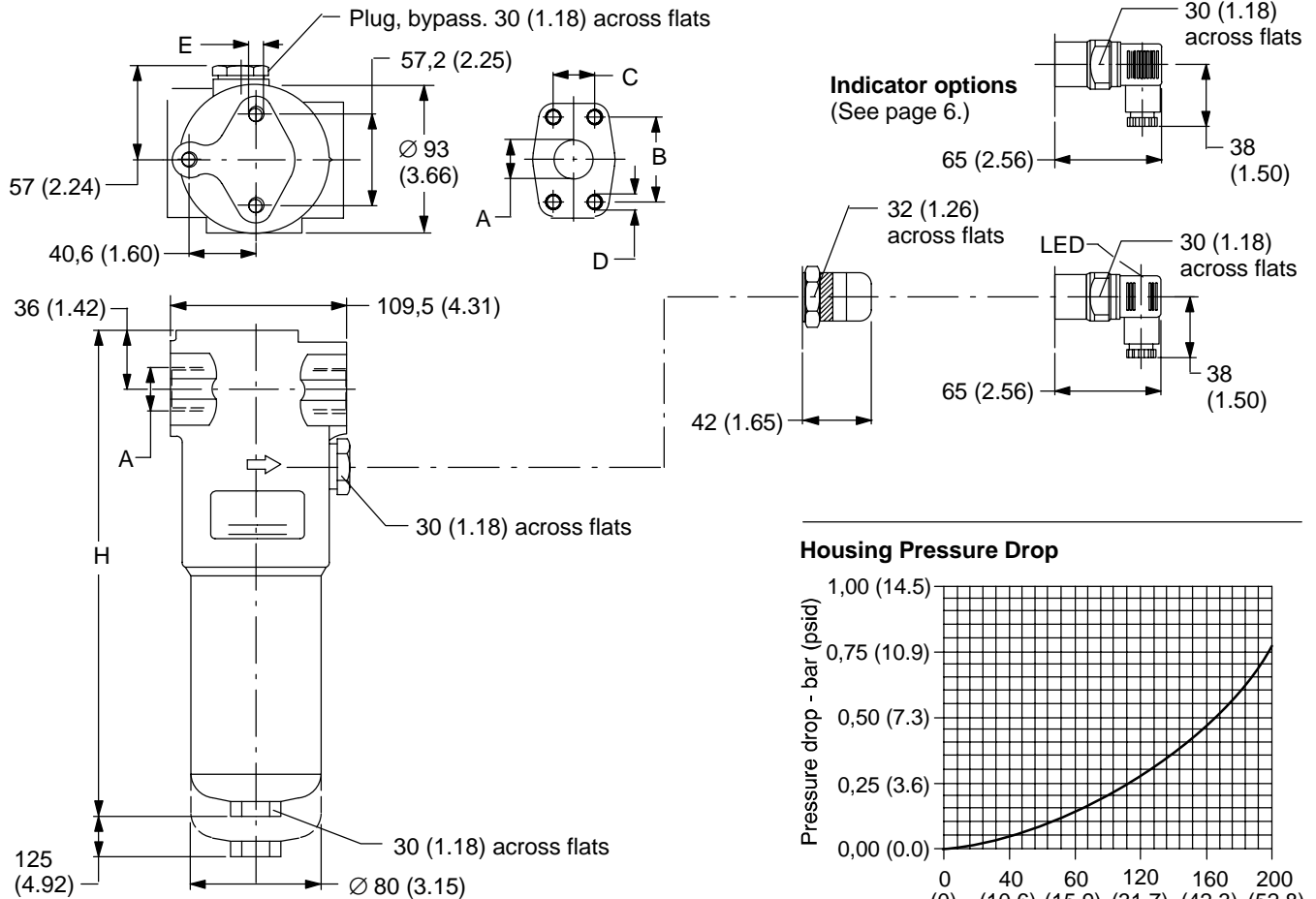

The following sizing recommendations are based on using mineral oil at 30 mm²/s (cSt) viscosity, maximum housing pressure drop 0,4 bar (6 psi), maximum clean element pressure drop 0,8 bar (12 psi). Refer to individual pressure drop curves, pages 13 and 14, to obtain filter assembly pressure drop information (ΔP Total = ΔP Housing + ΔP Element).

Micron code	Flow rate L/min (USgpm)		Bowl length code	H dim.	Port size BSP NPT SAE	Weight with element kg (lb)
	N element	H element				
A03	50 (13.2)	35 (9.2)	1	260 (10.24)	3/4"	7,5 (16.53)
A06	60 (15.9)	50 (13.2)				
A10	80 (21.1)	60 (15.9)				
A25	100 (26.4)	75 (19.8)				
A03	100 (26.4)	80 (21.1)	2	375 (14.76)	1"	9,4 (20.72)
A06	110 (29.1)	90 (23.8)				
A10	140 (37.0)	120 (31.7)				
A25	180 (47.6)	150 (39.6)				

Port code	Flange connections			
	A	B	C	D
F1	3/4" SAE - 3000 psi/M	47,63 (1.875)	22,23 (0.875)	M10
F2	1" SAE - 3000 psi/M	52,37 (2.062)	26,19 (1.031)	M10
F3	3/4" SAE - 3000 psi/UNC	47,63 (1.875)	22,23 (0.875)	3/8" UNC
F4	1" SAE - 3000 psi/UNC	52,37 (2.062)	26,19 (1.031)	3/8" UNC
F5	3/4" SAE - 6000 psi/M	50,80 (2.000)	23,80 (0.937)	M10
F6	3/4" SAE - 6000 psi/UNC	50,80 (2.000)	23,80 (0.937)	3/8" UNC

Housing Pressure Drop

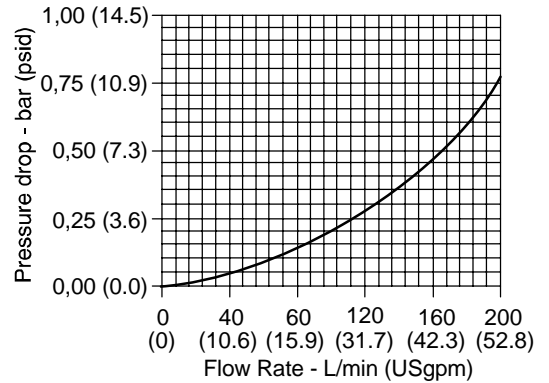

Bypass Valve Pressure Drop

Based on mineral oil with density of 0,86 kg/dm³. ΔP varies proportionally to density.

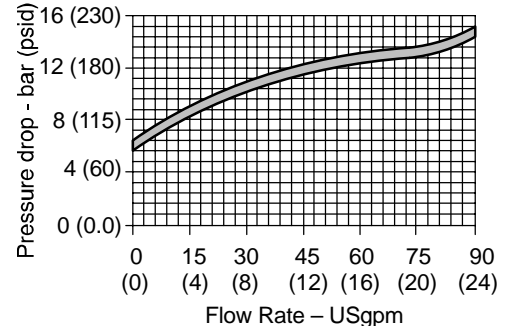

Ports code	Thread connections	
	A	E
G1	3/4" BSP	M10
G2	1" BSP	M10
G3	3/4" NPT	3/8" UNC
G4	1" NPT	3/8" UNC
G5	SAE 12 - 1 1/16" - 16 UN	3/8" UNC
G6	SAE 16 - 1 5/16" - 12 UN	3/8" UNC

OFP320/321 Selection & Installation

Dimensions in mm (inch)

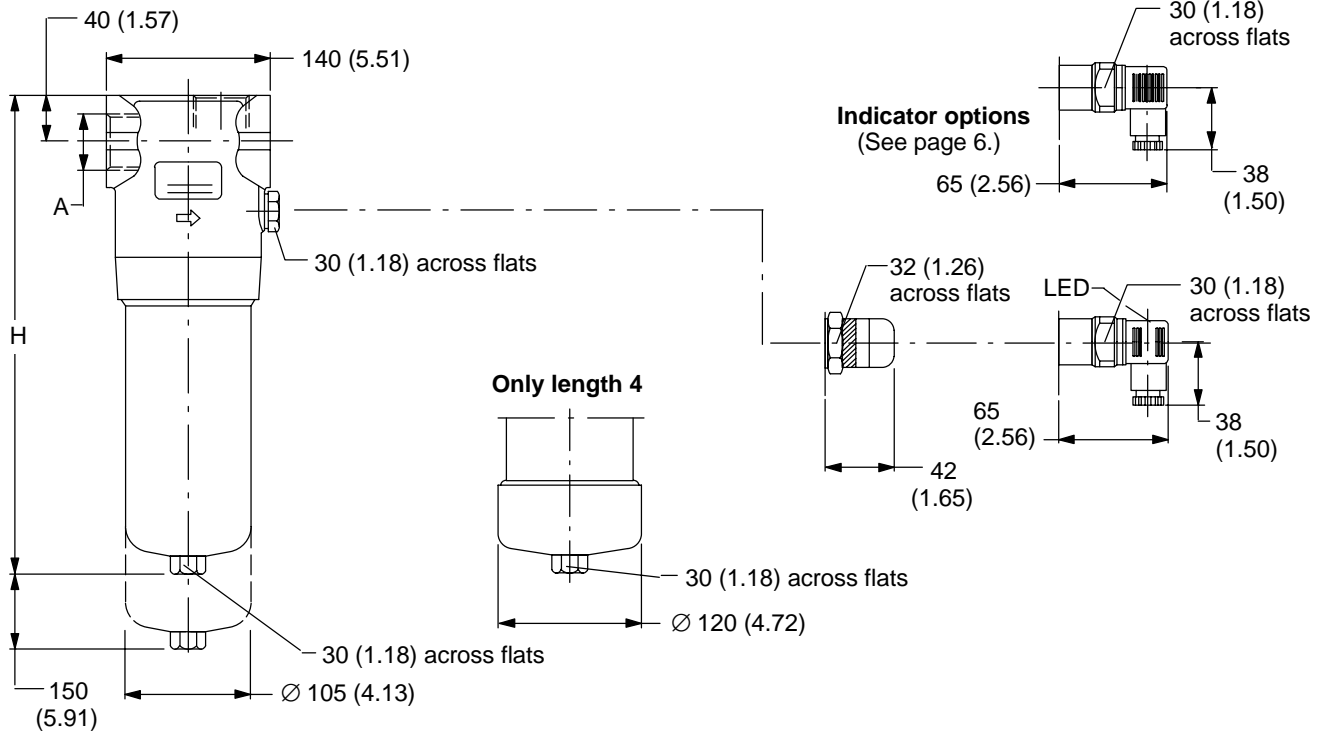
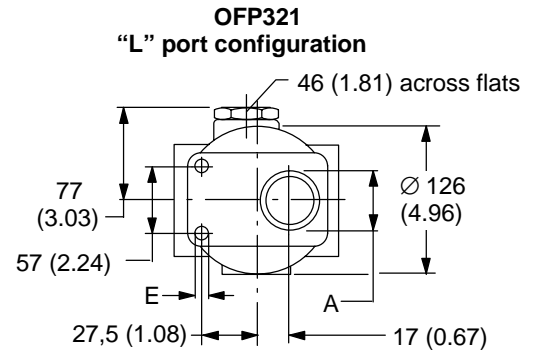
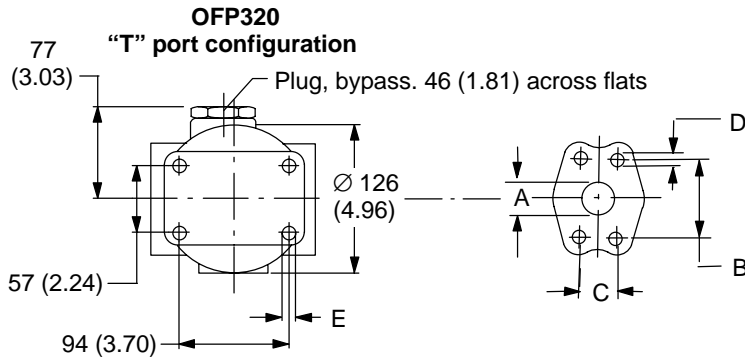

Ports code	Thread connections (OFP320 & 321)	
	A (inlet & outlet)	E
G1	1 1/4" BSP	M12
G2	1 1/2" BSP	M12
G3	1 1/4" NPT	1/2" UNC
G4	1 1/2" NPT	1/2" UNC
G5	SAE 20 - 1 5/8" - 16 UN	1/2" UNC
G6	SAE 24 - 1 7/8" - 12 UN	1/2" UNC

Ports code	Flange connections (available on OFP320 only)				
	A (inlet & outlet)	B	C	D	E
F1	1 1/4" SAE/M - 3000 psi	58,72 (2.312)	30,18 (1.188)	M10	M12
F2	1 1/2" SAE/M - 3000 psi	69,85 (2.750)	35,71 (1.406)	M12	M12
F3	1 1/4" SAE/UNC - 3000 psi	58,72 (2.312)	30,18 (1.188)	7/16" UNC	1/2" UNC
F4	1 1/2" SAE/UNC - 3000 psi	69,85 (2.750)	35,71 (1.406)	1/2" UNC	1/2" UNC
F5	1 1/4" SAE/M - 6000 psi	66,68 (2.625)	31,75 (1.250)	M14	M12
F6	1 1/4" SAE/UNC - 6000 psi	66,68 (2.625)	31,75 (1.250)	1/2" UNC	1/2" UNC

OFP320/321 Selection & Installation

Dimensions in mm (inch)

Housing Pressure Drop

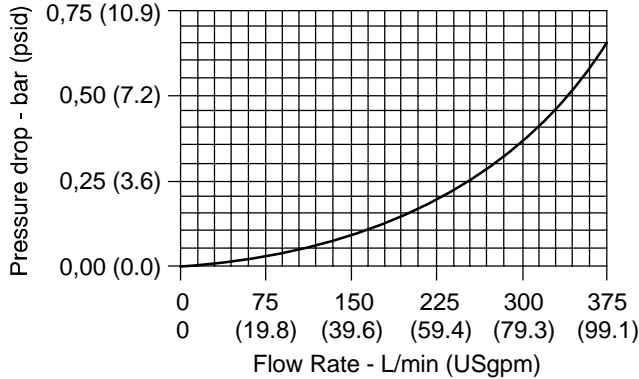

Bypass Valve Pressure Drop

Based on mineral oil with density of 0,86 kg/dm³.
 ΔP varies proportionally to density.

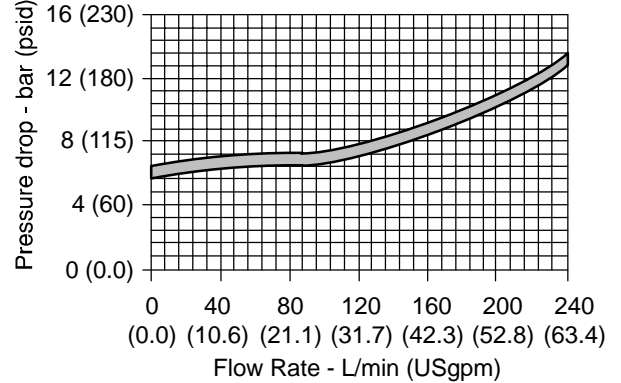

The following sizing recommendations are based on using mineral oil at 30 mm²/s (cSt) viscosity, maximum housing pressure drop 0,4 bar (6 psi), maximum clean element pressure drop 0,8 bar (12 psi). Refer to individual pressure drop curves, pages 13 and 14, to obtain filter assembly pressure drop information (ΔP Total = ΔP Housing + ΔP Element).

Micron code	Flow rate L/min (USgpm)		Bowl length code	H dim.	Port size BSP NPT SAE	Weight with element kg (lb)
	N element	H element				
A03	100 (26.4)	65 (17.2)	1	300 (11.81)	1-1/4"	14,5 (31.97)
A06	120 (31.7)	80 (21.1)				
A10	140 (37.0)	100 (26.4)				
A25	180 (47.6)	150 (39.6)				
A03	210 (55.5)	150 (39.6)	2	420 (16.54)	1-1/4"	16,5 (36.38)
A06	250 (66.0)	180 (47.6)				
A10	300 (79.3)	220 (58.1)				
A25	350 (92.5)	250 (66.0)				
A03	250 (66.0)	225 (59.4)	3	561 (22.09)	1-1/2"	22,5 (49.60)
A06	280 (74.0)	250 (66.0)				
A10	320 (84.5)	280 (74.0)				
A25	350 (92.5)	340 (89.8)				
A03	300 (79.3)	250 (66.0)	4	691 (27.20)	1-1/2"	25,5 (56.22)
A06	340 (89.8)	275 (72.6)				
A10	375 (99.1)	320 (84.5)				
A25	450 (118.9)	380 (100.4)				

OFF325 Selection & Installation

Dimensions in mm (inch)

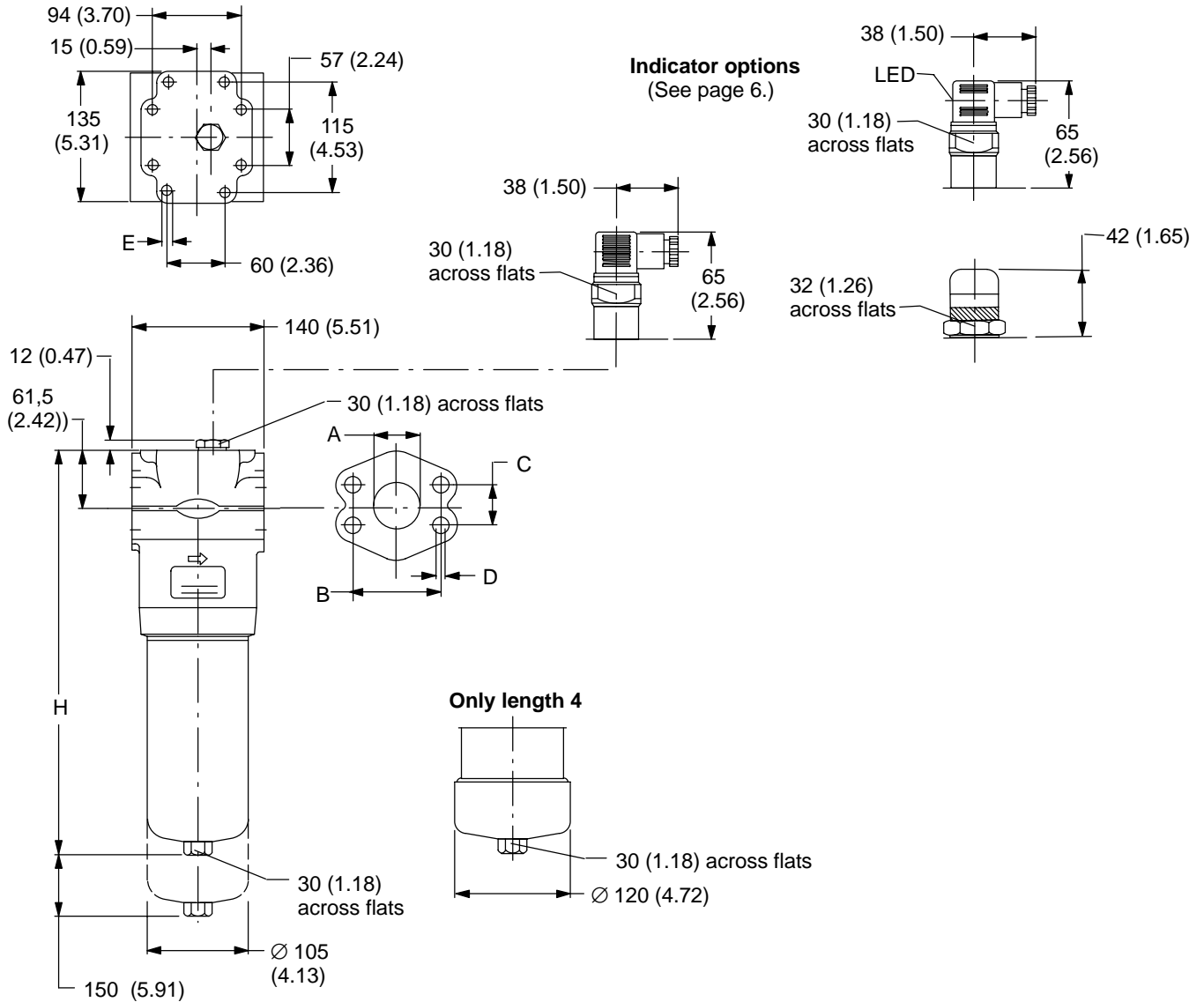

Ports code	A	B	C	D	E
F1	2" SAE/M - 3000 psi	77,77 (3.062)	42,88 (1.688)	M12	M12
F2	2" SAE/UNC - 3000 psi	96,82 (3.812)	42,88 (1.688)	1/2" UNC	1/2" UNC
F5	2" SAE/M - 6000 psi	77,77 (3.062)	44,45 (1.750)	M20	M12
F6	2" SAE/UNC - 3000 psi	96,82 (3.812)	44,45 (1.750)	3/4" UNC	3/4" UNC

OFP325 Selection & Installation

Dimensions in mm (inch)

Housing Pressure Drop

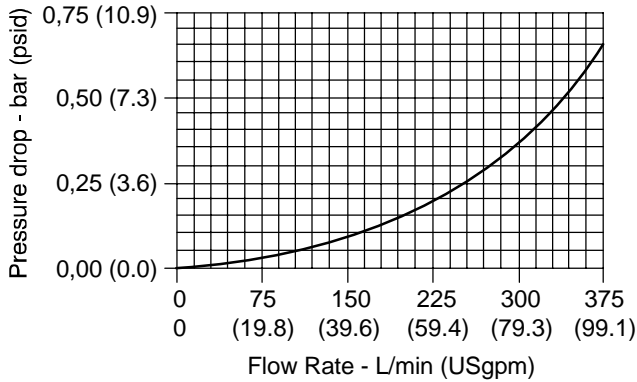

Bypass Valve Pressure Drop

Based on mineral oil with density of 0,86 kg/dm³.
 ΔP varies proportionally to density.

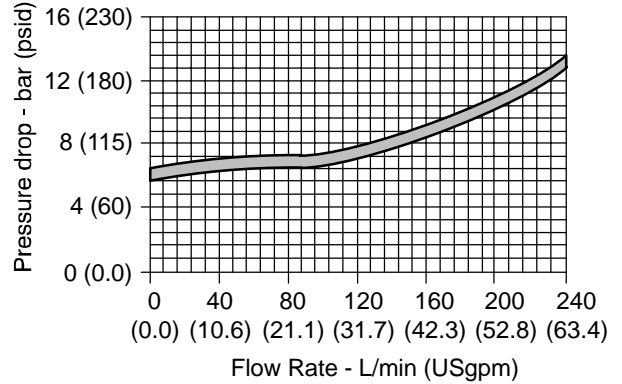

The following sizing recommendations are based on using mineral oil at 30 mm²/s (cSt) viscosity, maximum housing pressure drop 0,4 bar (6 psi), maximum clean element pressure drop 0,8 bar (12 psi). Refer to individual pressure drop curves, pages 13 and 14, to obtain filter assembly pressure drop information ($\Delta P_{\text{Total}} = \Delta P_{\text{Housing}} + \Delta P_{\text{Element}}$).

Micron code	Flow rate L/min (USgpm)		Bowl length code	H dim.	Port size BSP NPT SAE	Weight with element kg (lb)
	N element	H element				
A03	100 (26.4)	65 (17.2)	1	328 (12.91)	1-1/4"	14,5 (31.97)
A06	120 (31.7)	80 (21.1)				
A10	140 (37.0)	100 (26.4)				
A25	180 (47.6)	150 (39.6)				
A03	210 (55.5)	150 (39.6)	2	448 (17.64)	1-1/4"	16,5 (36.38)
A06	250 (66.0)	180 (47.6)				
A10	300 (79.3)	220 (58.1)				
A25	350 (92.5)	250 (66.0)				
A03	250 (66.0)	225 (59.4)	3	589 (23.19)	1-1/2"	22,5 (49.60)
A06	280 (74.0)	250 (66.0)				
A10	320 (84.5)	280 (74.0)				
A25	350 (92.5)	340 (89.8)				
A03	300 (79.3)	250 (66.0)	4	691 (27.20)	1-1/2"	25,5 (56.22)
A06	340 (89.8)	275 (72.6)				
A10	375 (99.1)	320 (84.5)				
A25	450 (118.9)	380 (100.4)				

OFP "N" Elements Pressure Drop

Based on mineral oil with a kinematic viscosity of 30 mm²/s (cSt).
 ΔP varies proportionally with kinematic viscosity.

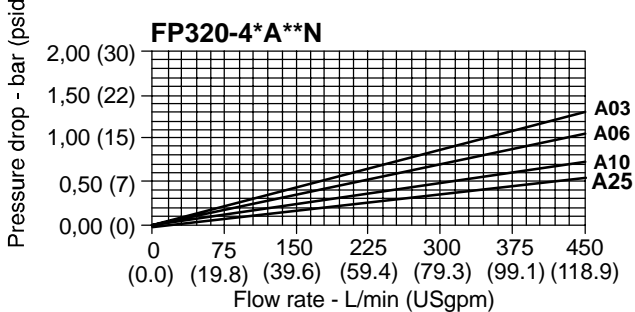
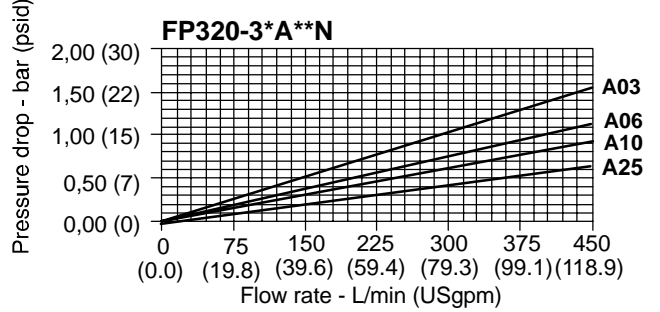
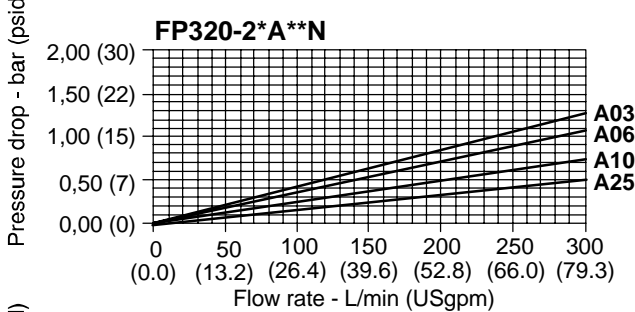
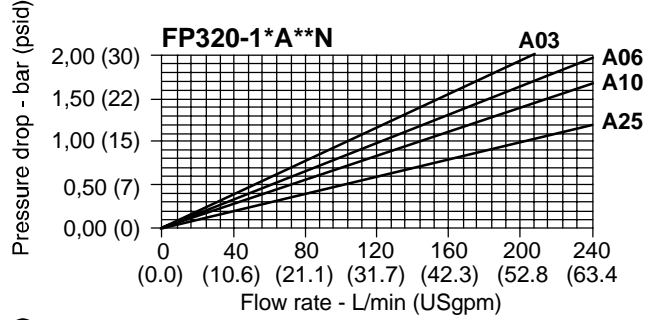
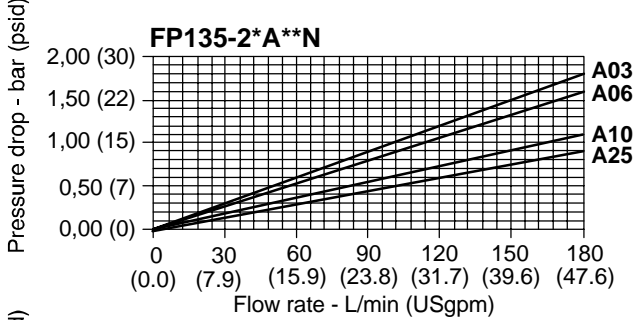
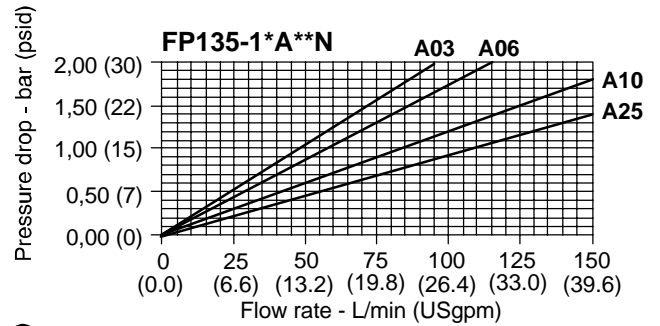
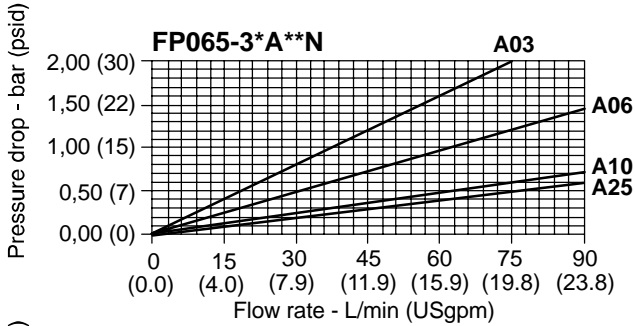
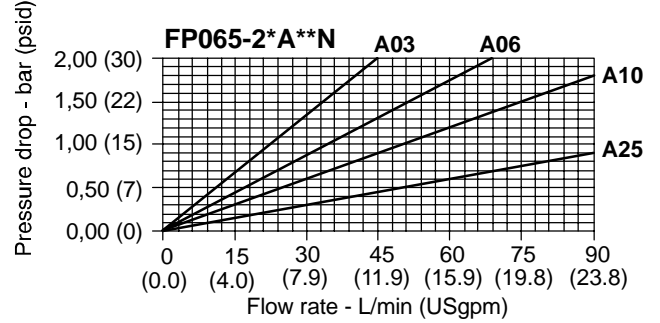
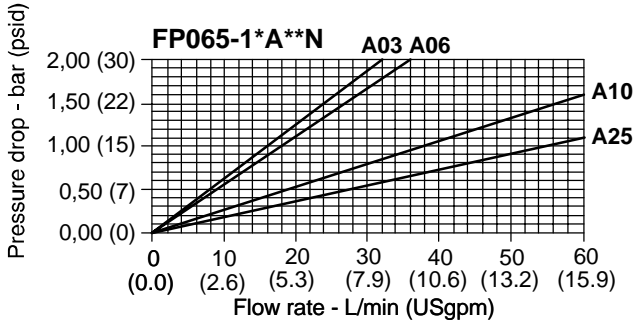

Note: OFP321 and OFP325 filters use FP320 series elements.

OFP "H" Elements Pressure Drop

Based on mineral oil with a kinematic viscosity of 30 mm²/s (cSt).
 ΔP varies proportionally with kinematic viscosity.

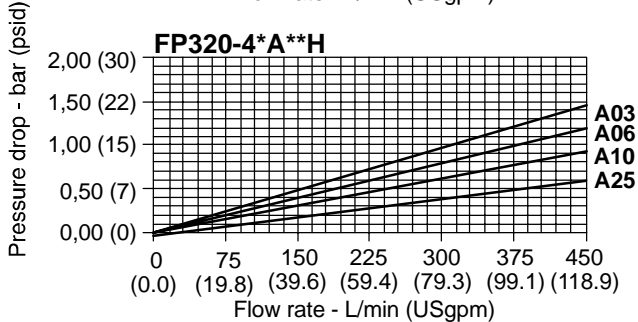
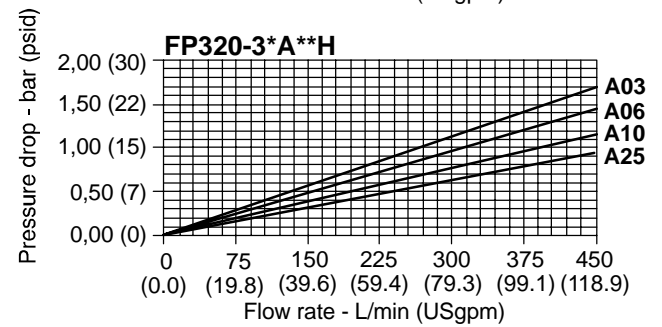
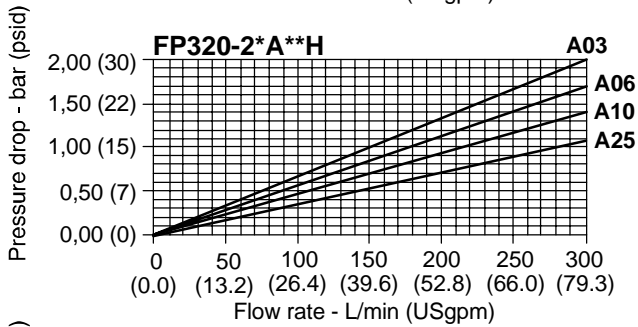
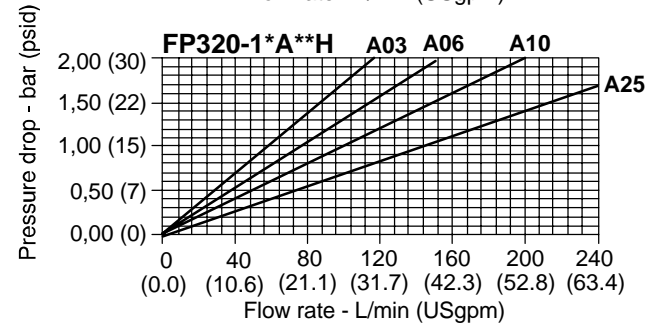
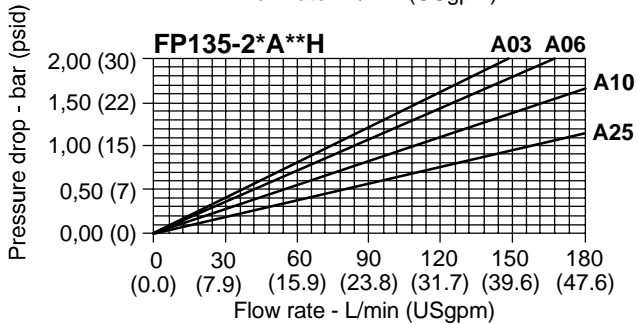
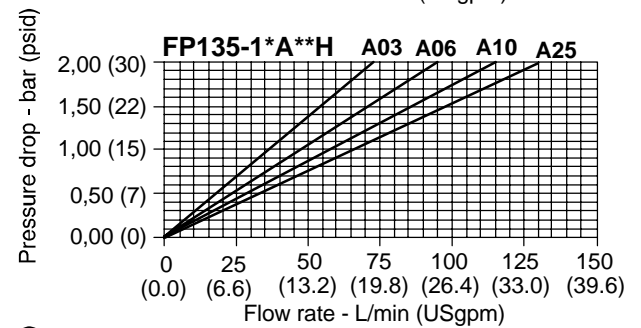
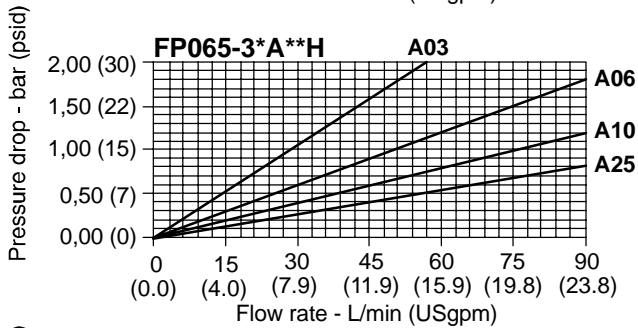
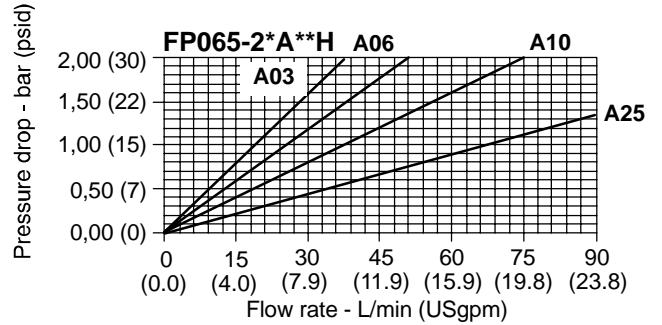
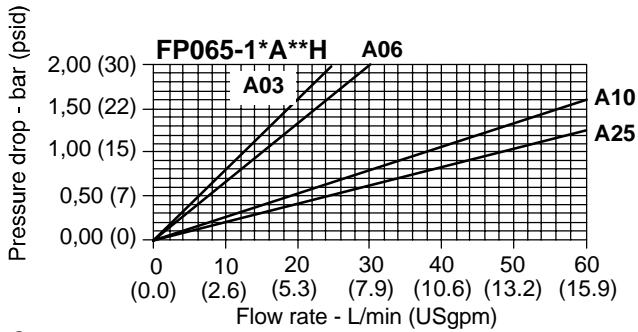

Note: OFP321 and OFP325 filters use FP320 series elements.

OFMT Model Codes

Filters:

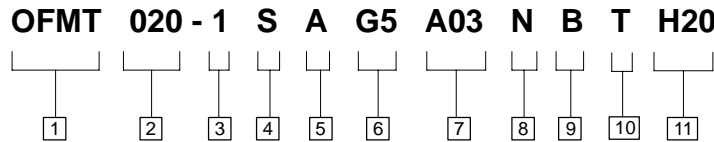

1 Filter series

OFMT – Return line filter

2 Nominal filter size

020
100

3 Bowl length

OFMT-020 = **1, 2, 3**
OFMT-100 = **1, 2, 3**

4 Air breather

S – Without breather
C – With 10 µm breather
M – With 40 µm breather

† Viton is a registered trade mark of E. I. DuPont

5 Seals

A – Nitrile (Buna-N)
V – Viton†

6 Port options

Ports code*	Nominal filter size	
	020	100
G1	3/8" BSP	3/4" BSP
G2	1/2" BSP	1" BSP
G3	–	1-1/4" BSP
G4	3/8" NPT	3/4" NPT
G5	1/2" NPT	1" NPT
G6	–	1-1/4" NPT
G7	SAE 6	SAE 12
G8	SAE 8	SAE 16
G9	–	SAE 20

7 Element micron rating

"N" element series:
P10 – 10 micron (nominal)
"H" element series:
A03 – 3 micron
A06 – 6 micron
A10 – 10 micron
X – Housing only

8 Element series (collapse pressure)

N – 3 bar (45 psi), P10 element only
H – 10 bar (150 psi), A** element only
– Omit for housing only.

9 Integral bypass valve

B – Bypass 1,75 bar (25 psi)
– Omit for housing only.

10 Element condition indicator

T – With plug (no indicator). Indicator to be ordered separately

11 Extension tube option

How to specify an extended tube:

- 1) Determine "H" dimension (including tube) in millimeters. Dimension *must* be in multiples of 10 and is subject to minimum lengths below.
- 2) Divide resulting dimension by 10 and add answer with an "H" suffix to end of model code.

Example: OFMT020-1SAG5A03NBT filter with "H" dimension of 200 millimeters would be OFMT020-1SAG5A03NBTH20.

Minimum Lengths:

OFMT020-1 = 160mm/6.29 in.
OFMT020-2 = 270mm/10.63 in.
OFMT020-3 = 310mm/12.20 in.
OFMT100-1 = 200mm/7.87 in.
OFMT100-2 = 250mm/9.84 in.
OFMT100-3 = 330mm/12.99 in.

Replacement elements:

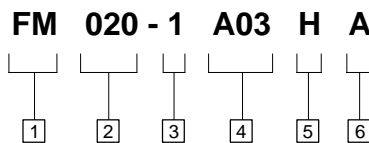

1 Element series

FM – Element for return line filter

2 Nominal filter size

020
100

3 Filter bowl length

OFMT-020 = **1, 2, 3**
OFMT-100 = **1, 2, 3**

4 Micron rating

"N" collapse pressure:
P10 – 10 micron (nominal)
"H" collapse pressure:
A03 – 3 micron
A06 – 6 micron
A10 – 10 micron

5 Element collapse pressure

N – 3 bar (45 psi), "P10" micron only
H – 10 bar (150 psi), "A**" micron only

6 Seals

A – Nitrile (Buna-N)
V – Viton

Note: 1,75 bar (25 psi) bypass is incorporated in the filter element.

OFMT Specifications

Flow rate

OFMT020: See pages 17.
OFMT100: See pages 18.

Element collapse pressure

N element: 3 bar (45 psi)
H element: 10 bar (150 psi)

Filter body

Max. pressure: 7 bar (100 psi)
Test pressure: 10 bar (150 psi)
Min. burst press: 20 bar (300 psi)
Fatigue test: Body subjected to pressure impulses from 0 to 7 bar (0 to 100 psi) will withstand one million cycles.

Material

Head: Die cast aluminum
Cover & bowl: Nylon
Element media: Glass microfiber or resin-impregnated paper
Seals: Nitrile (Buna-N)
Viton

Housing and element fluid compatibility

Compatible with most petroleum oil, water glycol, oil-in-water and water-in-oil fluids. Optional seals available for phosphate esters.

Bypass valve

Valve starts to open when pressure drop across filter element exceeds 1,75 bar (25 psi) due to flow surges, high viscosity oil, clogged element, or a combination of these factors.

Micron rating

A03 code: 3 micron
A06 code: 6 micron
A10 code: 10 micron
P10 code: 10 micron (nominal)

Temperature range

– 25 °C to +110 °C
(– 13 °F to +230 °F)

Dry weight (approximate)

OFMT020: See pages 17.
OFMT100: See pages 18.

OFMT020 Selection & Installation

Dimensions in mm (inch)

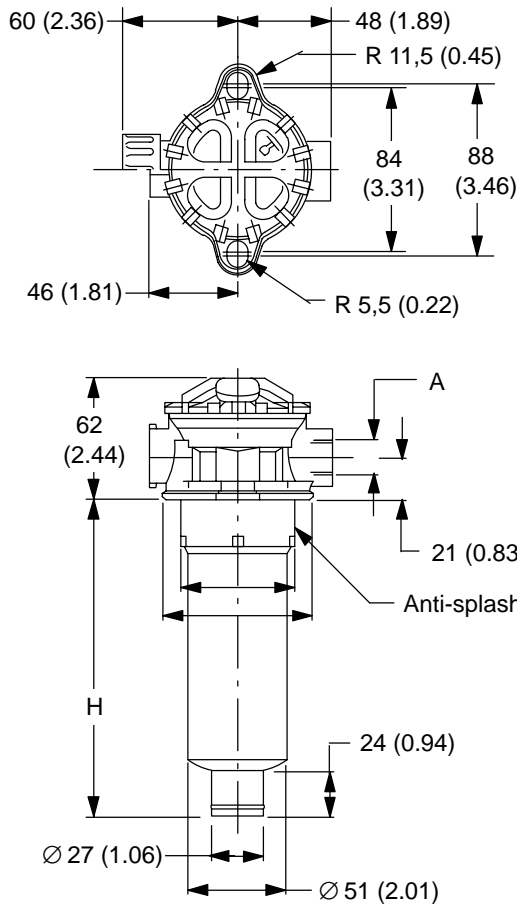

Ports code	A (port thd. connections)
G1	3/8" BSP
G2	1/2" BSP
G4	3/8" NPT
G5	1/2" NPT
G7	SAE 6 - 9/16" - 18 UNF
G8	SAE 8 - 3/4" - 16 UN

Holes required on tank

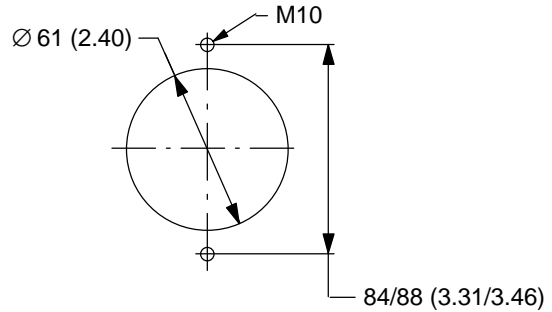

The following sizing recommendations are based on using mineral oil at 30 mm²/s (cSt) viscosity, maximum housing pressure drop 0,15 bar (2 psi), maximum clean element pressure drop 0,35 bar (5 psi). Refer to individual pressure drop curves, page 19, to obtain filter assembly pressure drop information ($\Delta P_{\text{Total}} = \Delta P_{\text{Housing}} + \Delta P_{\text{Element}}$).

Micron code	Flow rate L/min (USgpm)	Bowl length code	H dim.	Port size BSP NPT SAE	Weight with element kg (lb)
A03 A06 A10 P10	17 (4.5) 22 (5.8) 30 (7.9) 35 (9.2)	1	102 (4.02)	3/8"	0,3 (0.66)
A03 A06 A10 P10	20 (5.3) 23 (6.1) 35 (9.2) 45 (11.9)	2	165 (6.50))	3/8" 3/8" 1/2"	0,4 (0.88)
A03 A06 A10 P10	30 (7.9) 35 (9.2) 50 (13.2) 75 (19.8)	3	210 (8.27)	3/8" 3/8" 1/2" 1/2"	0,5 (1.10)

Housing Pressure Drop

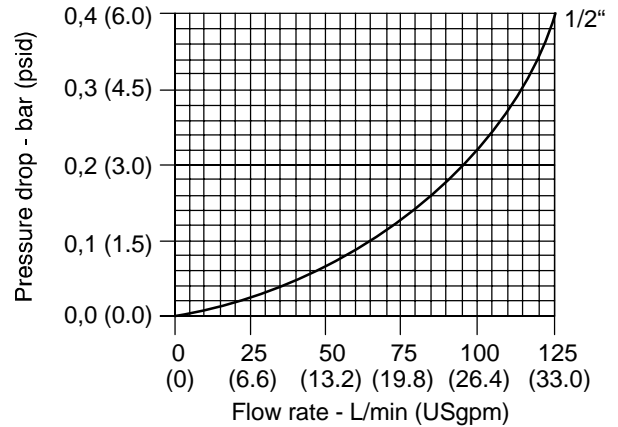

Bypass Valve Pressure Drop

Based on mineral oil with density of 0,86 kg/dm³. ΔP varies proportionally to density.

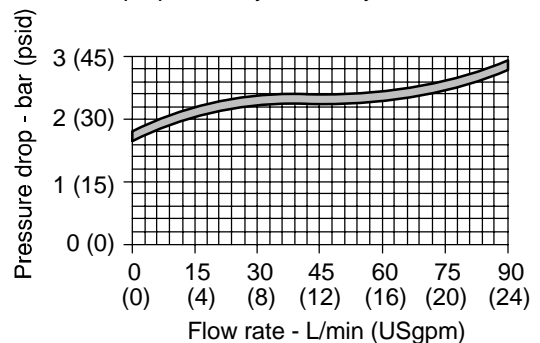

OFMT100 Selection & Installation

Dimensions in mm (inch)

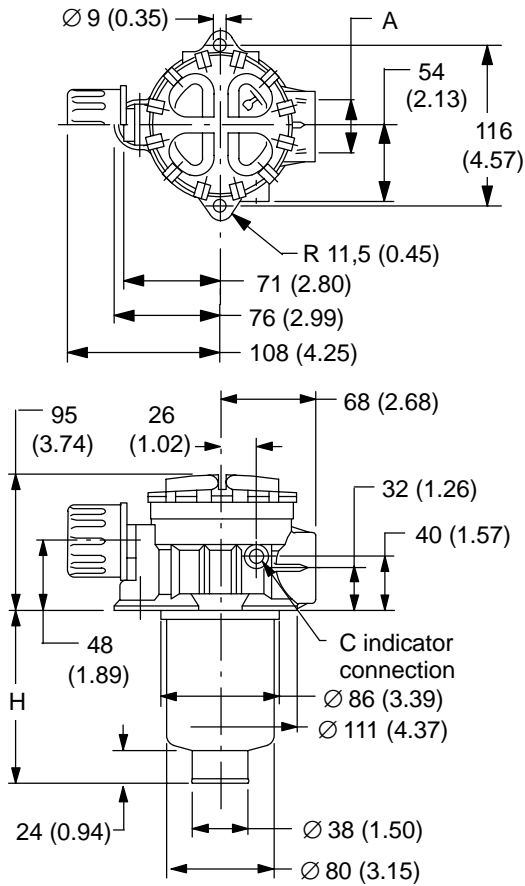

The following sizing recommendations are based on using mineral oil at 30 mm²/s (cSt) viscosity, maximum housing pressure drop 0,15 bar (2 psi), maximum clean element pressure drop 0,35 bar (5 psi). Refer to individual pressure drop curves, page 19, to obtain filter assembly pressure drop information (ΔP Total = ΔP Housing + ΔP Element).

Micron code	Flow rate L/min (USgpm)	Bowl length code	H dim.	Port size BSP NPT SAE	Weight with element kg (lb)
A03 A06 A10 P10	25 (6.6) 30 (7.9) 35 (9.2) 50 (13.2)	1	102 (4.02)	3/4"	1 (2.20)
A03 A06 A10 P10	32 (8.5) 38 (10.0) 45 (11.9) 100 (26.4)	2	145 (5.71)	3/4" 3/4" 3/4" 1"	1,2 (2.65)
A03 A06 A10 P10	45 (11.9) 55 (14.5) 70 (18.5) 125 (33.0)	3	225 (8.86)	1" 1" 1-1/4" 1-1/4"	1,3 (2.87)

Ports code	A (inlet & outlet conn.)	C
G1	3/4" BSP	1/8" BSP
G2	1" BSP	1/8" BSP
G3	1-1/4" BSP	1/8" BSP
G4	3/4" NPT	1/8" NPT
G5	1" NPT	1/8" NPT
G6	1-1/4" NPT	1/8" NPT
G7	SAE 12 - 1 1/16" - 12 UN	1/8" NPT
G8	SAE 16 - 1 5/16" - 12 UN	1/8" NPT
G9	SAE 20 - 1 5/8" - 12 UN	1/8" NPT

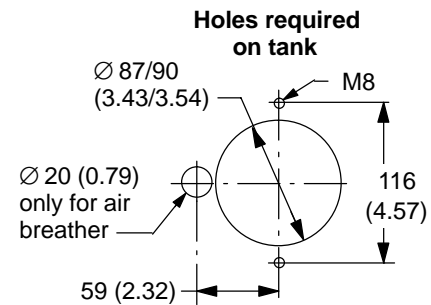

Housing Pressure Drop

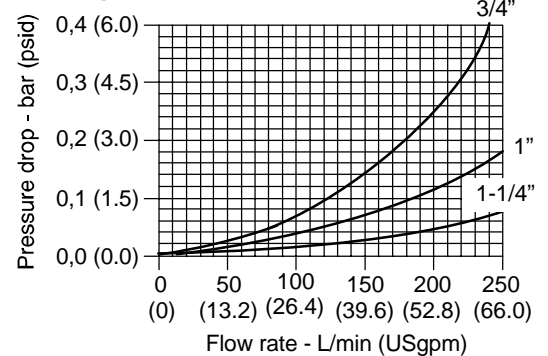

Bypass Valve Pressure Drop

Based on mineral oil with density of 0,86 kg/dm³. ΔP varies proportionally to density.

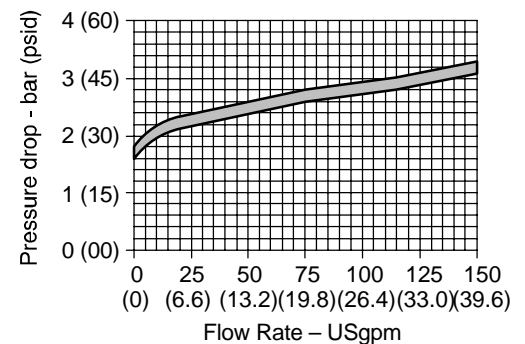

OFMT "N" Elements Pressure Drop

Based on mineral oil with a kinematic viscosity of 30 mm²/s (cSt).
 ΔP varies proportionally to kinematic viscosity.

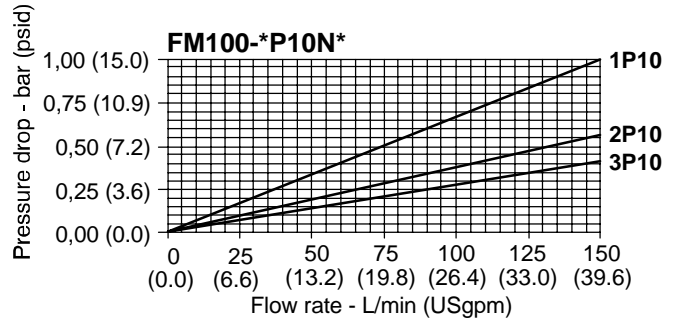
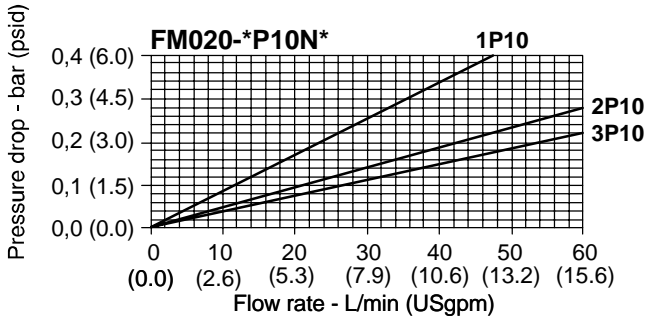

OFMT "H" Elements Pressure Drop

Based on mineral oil with a kinematic viscosity of 30 mm²/s (cSt).
 ΔP varies proportionally to kinematic viscosity.

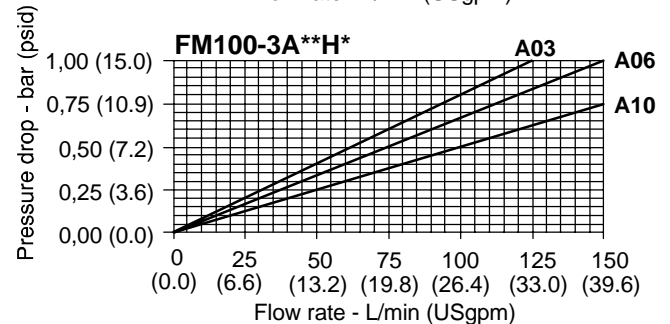
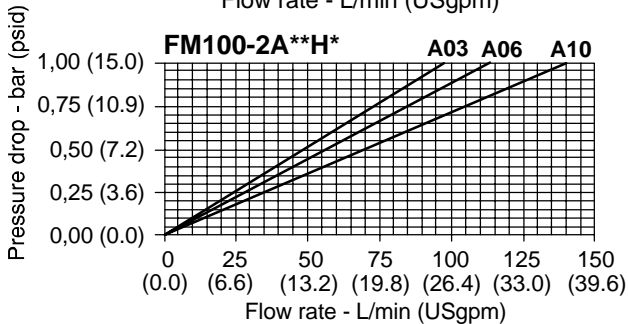
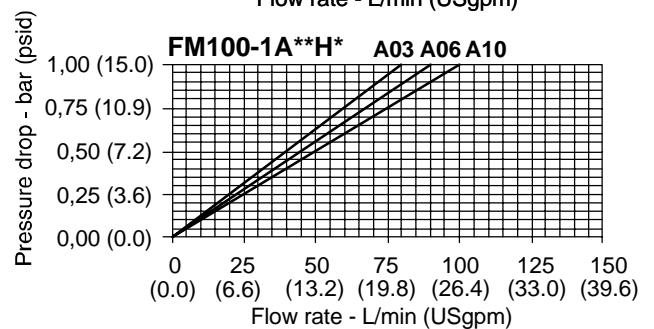
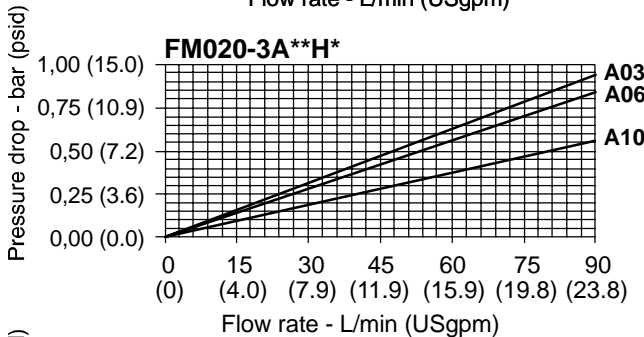
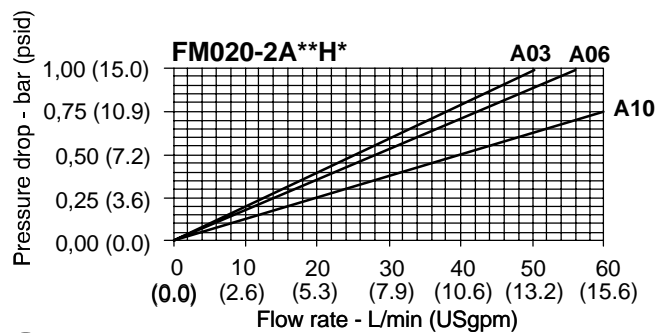
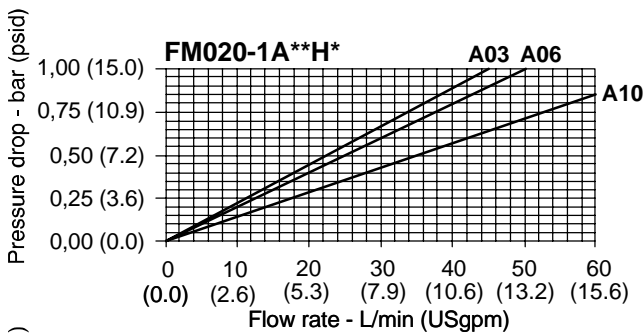

OFRT Filter Model Codes

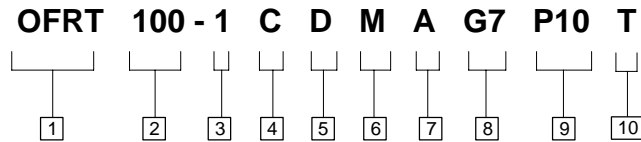

1 Filter series

OFRT – Return line filter

2 Nominal filter size

100
250
630
850

3 Bowl length

OFRT-100 = 1, 2, 3, 4
OFRT-250 = 1, 2, 3, 4
OFRT-630 = 1, 2, 3, 4
OFRT-850 = 1, 2, 3, 4

4 Integral bypass valve

C – 1,75 bar (25 psi)

5 Diffuser

O – Without diffuser
D – With diffuser

6 Air breather

S – Without breather
C – 10 μ breather (100 size only)
M – 40 μ breather (100 size only)

7 Seals

A – Nitrile (Buna-N)

Note: Viton seals are not available as a standard offering. Contact Vickers for information on availability.

Viton is a registered trademark of E. I. DuPont.

8 Port options

Ports code †	Nominal filter size			
	100	250 ‡	630 ‡	850 ‡
G1	3/4" BSP	1-1/2" BSP	–	–
G2	1" BSP	1-1/2" BSP 1-1/4" BSP	–	–
G3	1-1/4" BSP	–	–	–
G4	3/4" NPT	1-1/2" BSP	–	–
G5	1" NPT	1-1/2" NPT 1-1/4" NPT	–	–
G6	1-1/4" NPT	–	–	–
G7	SAE 12	SAE 24	–	–
G8	SAE 16	SAE 24 SAE 20	–	–
G9	SAE 20	–	–	–
F1	–	1-1/2" SAE/M	2-1/2" SAE/M	DN 100 PN 10/16 3" SAE/M
F2	–	1-1/2" SAE/M 1-1/4" SAE/M	2-1/2" SAE/M 2" SAE/M	–
F3	–	1-1/2" SAE/UNC	2-1/2" SAE/UNC	DN 100 PN 10/16 3" SAE/UNC
F4	–	1-1/2" SAE/UNC 1-1/4" SAE/UNC	2-1/2" SAE/UNC 2" SAE/UNC	–

† G codes are for thread connections. F codes are for flange connections with metric (F1 and F2) or inch (F3 and F4) bolt holes.

‡ 250 size filter with G2, G5 or G8 port code has dual inlets.
250 and 630 size filters with F2 or F4 port code have dual inlets.
850 size filters have dual inlets.

9 Element type and micron rating

Glass microfiber element:

A06 – 6 micron

A10 – 10 micron

Resin-impregnated paper element:

P10 – 10 micron (nominal)

P25 – 25 micron (nominal)

X – Housing only

10 Element condition indicator

T – With plug (no indicator). Indicator to be ordered separately.

OFRT Replacement Element Model Codes

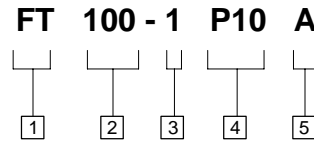

1 Element series

FT – Element for return line filter

2 Nominal filter size

100
250
630
850

3 Filter bowl length

OFRT-100 = **1, 2, 3, 4**
OFRT-250 = **1, 2, 3, 4**
OFRT-630 = **1, 2, 3, 4**
OFRT-850 = **1, 2, 3, 4**

5 Seals

A – Nitrile (Buna-N)

4 Element type and micron rating

Glass microfiber element:

A06 – 6 micron

A10 – 10 micron

Resin-impregnated paper element:

P10 – 10 micron (nominal)

P25 – 25 micron (nominal)

OFRT Specifications

Flow rate

OFRT100: See page 23.
OFRT250: See page 25.
OFRT630: See page 27.
OFRT850: See page 29.

Bypass valve

Valve starts to open when pressure drop across filter element exceeds 1,75 bar (25 psi) due to flow surges, high viscosity oil, clogged element, or a combination of these factors.

Micron rating

Glass microfiber element:

A06 code 6 micron

A10 code 10 micron

Resin-impregnated paper element:

P10 code 10 micron (nominal)

P25 code 25 micron (nominal)

Element collapse pressure

10 bar (150 psi)

Material

Head: Die cast aluminum

Cover:

OFRT100 Nylon

OFRT250/630 Aluminum

OFRT850 Steel

Diffuser: Steel

Element media: Glass microfiber or resin-impregnated paper

Seals: Nitrile (Buna-N)

Viton

Temperature range

– 25°C to +110°C

(– 13°F to +230°F)

Filter body

Max. pressure: 10 bar (150 psi)
Test pressure: 15 bar (225 psi)
Min. burst press: 30 bar (450 psi)
Fatigue test: Body subjected to pressure impulses from 0 to 10 bar (0 to 150 psi) will withstand one million cycles.

Dry weight (approximate)

OFRT100: See page 23.

OFRT250: See page 25.

OFRT630: See page 27.

OFRT850: See page 29.

Housing and element fluid compatibility

Compatible with most petroleum oil, water glycol, oil-in-water and water-in-oil fluids. Optional seals available for phosphate esters.

OFRT100 Selection & Installation

Dimensions in mm (inch)

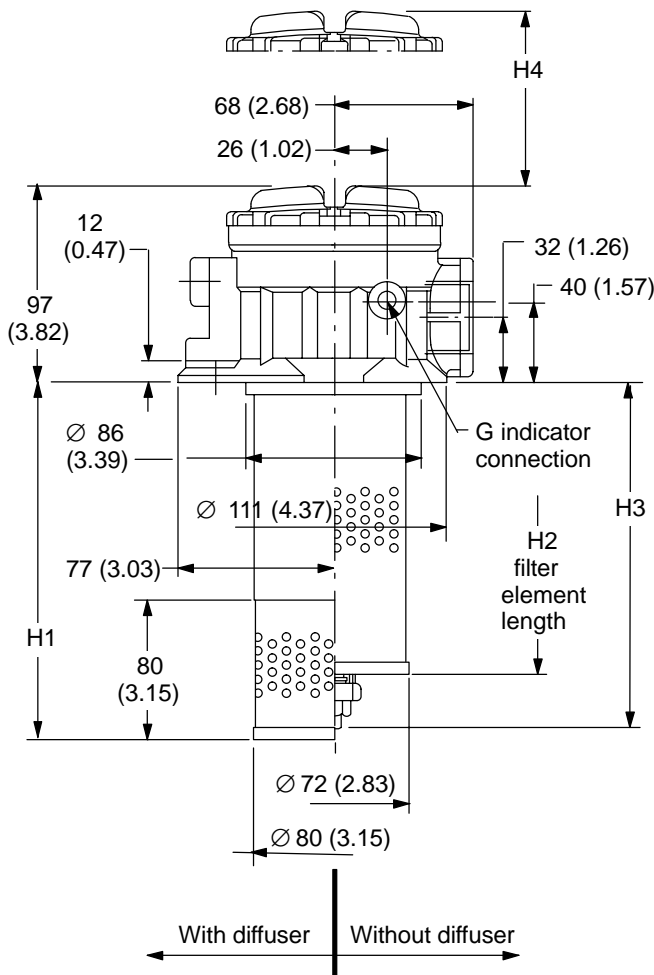
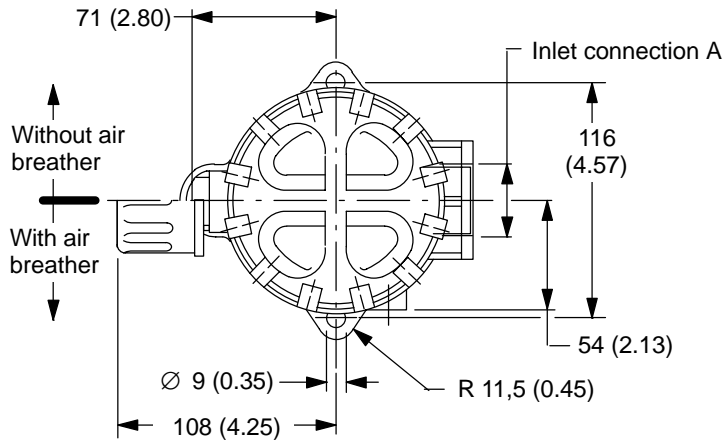

Holes required on tank

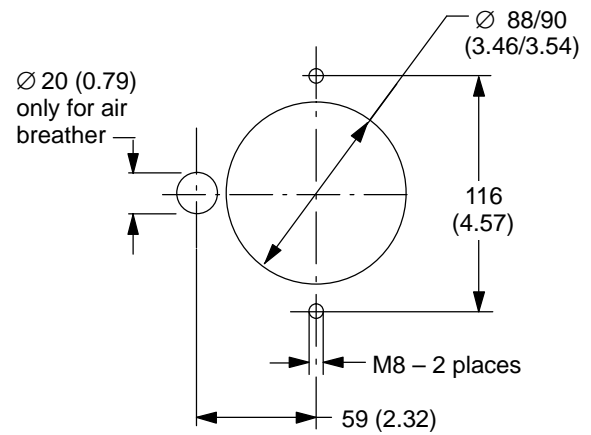

Bowl length code	Dimensions			
	H1	H2	H3	H4
1	178 (7.01)	106 (4.17)	128 (5.04)	190 (7.48)
2	178 (7.01)	150 (5.91)	172 (6.77)	230 (9.06)
3	228 (8.98)	200 (7.87)	222 (8.74)	280 (11.02)
4	328 (12.91)	300 (11.81)	322 (12.68)	380 (14.96)

Port code	Thread connections	
	A	G
G1	3/4" BSP	1/8" BSP
G2	1" BSP	1/8" BSP
G3	1 1/4" BSP	1/8" BSP
G4	3/4" NPT	1/8" NPT
G5	1" NPT	1/8" NPT
G6	1 1/4" NPT	1/8" NPT
G7	SAE 12 - 1 1/16" -12 UN	1/8" NPT
G8	SAE 16 - 1 5/16" -12 UN	1/8" NPT
G9	SAE 20 - 1 5/8" -12 UN	1/8" NPT

OFRT100 Selection & Installation

Dimensions in mm (inch)

Housing Pressure Drop

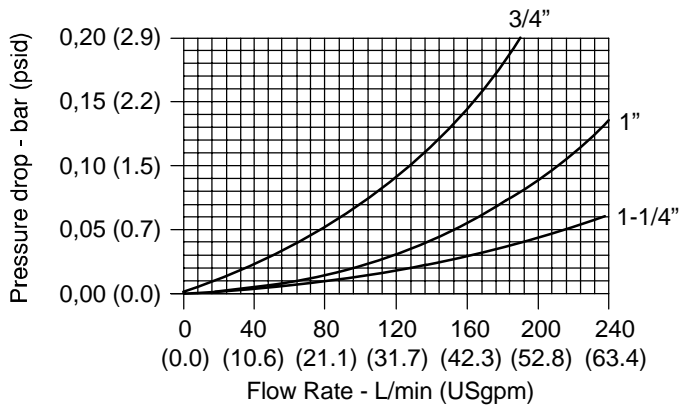

Bypass Valve Pressure Drop

Based on mineral oil with density of 0,86 kg/dm³.
 ΔP varies proportionally to density.

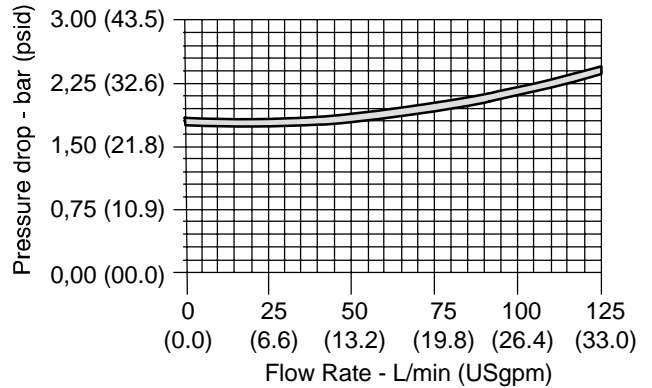

The following sizing recommendations are based on using mineral oil at 30 mm²/s (cSt) viscosity, maximum housing pressure drop 0,15 bar (2 psi), maximum clean element pressure drop 0,35 bar (5 psi). Refer to individual pressure drop curves, pages 31 through 34, to obtain filter assembly pressure drop information (ΔP Total = ΔP Housing + ΔP Element).

Micron code	Flow rate L/min (USgpm)	Bowl length code	Port size BSP NPT SAE	Weight with element and diffuser kg (lb)
A06	27 (7.1)	1	3/4"	1,0 (2.20)
A10	35 (9.2)			
P10	80 (21.1)			
P25	80 (21.1)			
A06	35 (9.2)	2	3/4"	1,2 (2.63)
A10	40 (10.6)			
P10	100 (26.4)			
P25	100 (26.4)			
A06	55 (14.5)	3	1"	1,3 (2.87)
A10	75 (19.8)			
P10	130 (34.3)			
P25	130 (34.3)			
A06	70 (18.5)	4	1-1/4"	1,5 (3.31)
A10	105 (27.7)			
P10	190 (50.2)			
P25	190 (50.2)			

OFRT250 Selection & Installation

Dimensions in mm (inch)

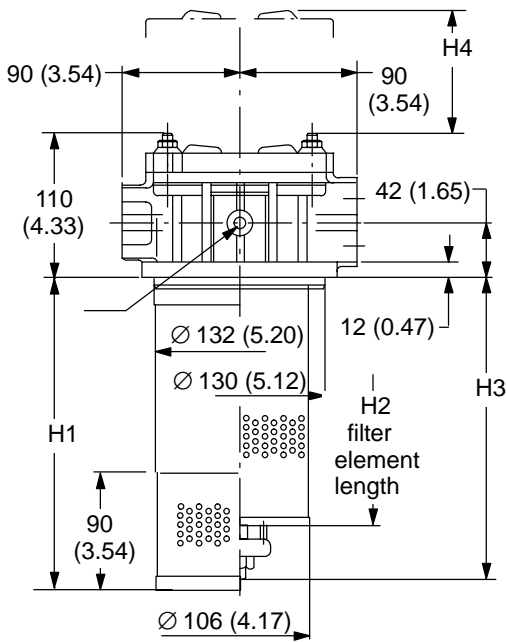
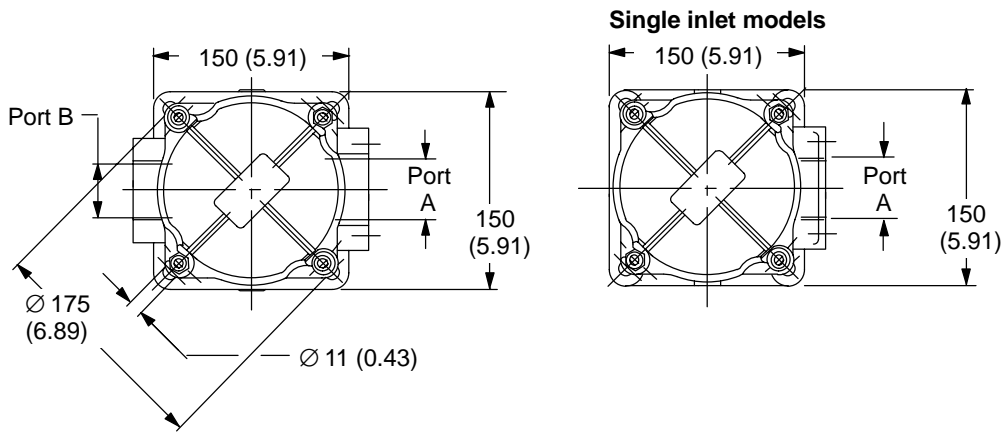

With diffuser | Without diffuser

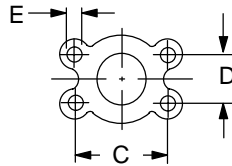

Bowl length code	Dimensions			
	H1	H2	H3	H4
1	240 (9.45)	140 (5.51)	175 (6.89)	260 (10.24)
2	240 (9.45)	190 (7.48)	225 (8.86)	310 (12.20)
3	310 (12.20)	260 (10.24)	295 (11.61)	380 (14.96)
4	515 (20.28)	465 (18.31)	500 (19.69)	580 (22.83)

Ports code	Thread connections		
	Port A	Port B	G
G1	1 1/2" BSP	Not available	1/8" BSP
G2	1 1/2" BSP	1 1/4" BSP	1/8" BSP
G4	1 1/2" NPT	Not available	1/8" NPT
G5	1 1/2" NPT	1 1/4" NPT	1/8" NPT
G7	SAE 24 - 1 7/8" -12 UN	Not available	1/8" NPT
G8	SAE 24 - 1 7/8" -12 UN	SAE 20 - 1 5/8" -12 UN	1/8" NPT

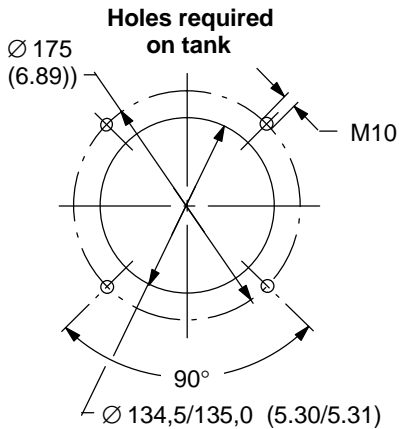

Port code	Flange connections - single port			
	Port A	C	D	E
F1	1 1/2" SAE - 3000 psi/M	69,85 (2.750)	35,71 (1.406)	M12
F3	1 1/2" SAE - 3000 psi/UNC			1/2" BSP

Ports code	Flange connections - dual ports			
	Ports A and B †	C	D	E
F2	1 1/2" SAE/M - 3000 psi	69,85 (2.750)	35,71 (1.406)	M12
	1 1/4" SAE/M - 3000 psi	58,72 (2.312)	30,18 (1.188)	M10
F4	1 1/2" SAE/UNC - 3000 psi	69,85 (2.750)	35,71 (1.406)	1/2" UNC
	1 1/4" SAE/UNC - 3000 psi	58,72 (2.312)	30,18 (1.188)	3/8" UNC

† Port A is 1 1/2".

OFRT250 Selection & Installation

Dimensions in mm (inch)

Housing Pressure Drop

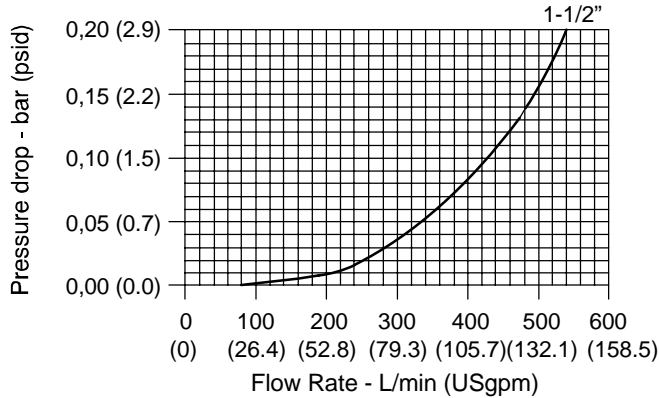

Bypass Valve Pressure Drop

Based on mineral oil with density of 0,86 kg/dm³.
 ΔP varies proportionally to density.

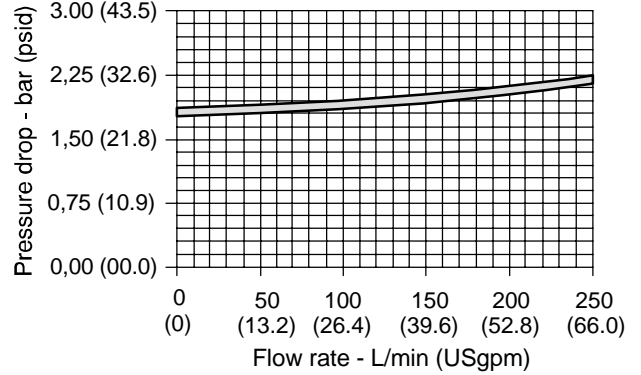

The following sizing recommendations are based on using mineral oil at 30 mm²/s (cSt) viscosity, maximum housing pressure drop 0,15 bar (2 psi), maximum clean element pressure drop 0,35 bar (5 psi). Refer to individual pressure drop curves, pages 31 through 34, to obtain filter assembly pressure drop information (ΔP Total = ΔP Housing + ΔP Element).

Micron code	Flow rate L/min (USgpm)	Bowl length code	Port size BSP NPT SAE	Weight with element and diffuser kg (lb)
A06	100 (26.4)	1	1-1/2"	3,9 (8.60) †
A10	115 (30.4)			
P10	180 (47.6)			
P25	180 (47.6)			
A06	120 (31.7)	2	1-1/2"	4,1 (9.04) †
A10	160 (42.3)			
P10	200 (52.8)			
P25	200 (52.8)			
A06	170 (44.9)	3	1-1/2"	4,6 (10.14) †
A10	205 (54.2)			
P10	260 (68.7)			
P25	260 (68.7)			
A06	300 (79.3)	4	1-1/2"	4,8 (10.58) †
A10	360 (95.1)			
P10	450 (118.9)			
P25	450 (118.9)			

† Single port models

‡ Dual port models

OFRT630 Selection & Installation

Dimensions in mm (inch)

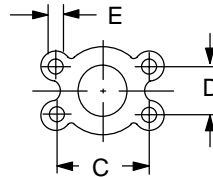
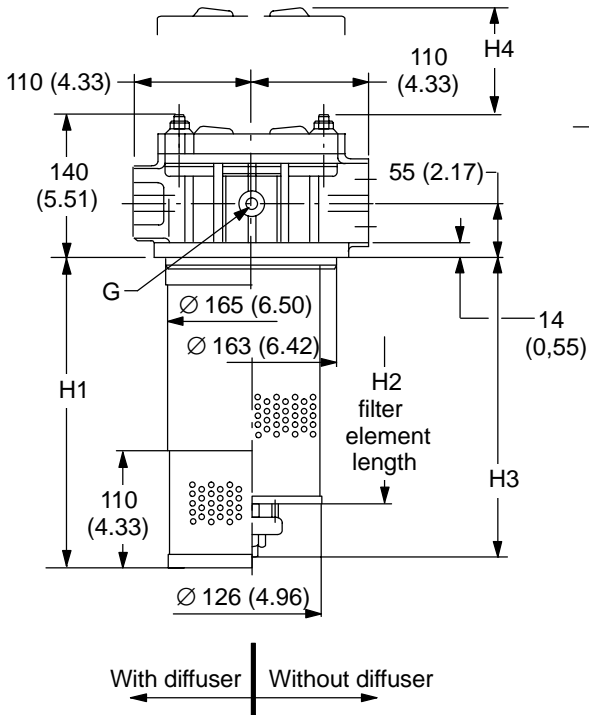
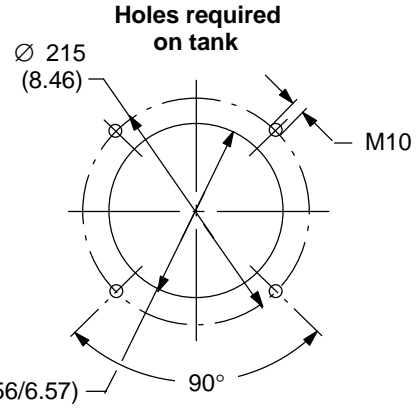
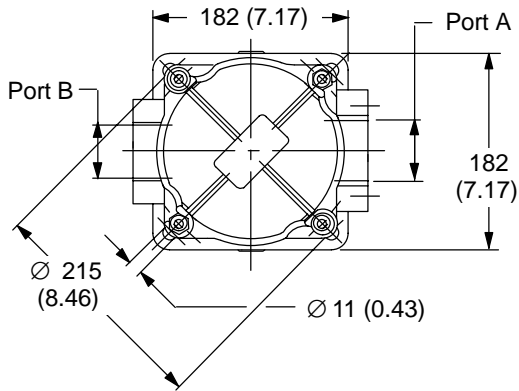

Bowl length code	Dimensions			
	H1	H2	H3	H4
1	280 (11.02)	210 (8.27)	260 (10.24)	350 (13.78)
2	360 (14.17)	290 (11.42)	340 (13.39)	430 (16.93)
3	460 (18.11)	390 (15.35)	440 (17.32)	530 (20.87)
4	550 (21.65)	478 (18.82)	530 (20.87)	620 (24.41)

Port code	Flange connections - single port				
	Port A	C	D	E	G
F1	2 1/2" SAE/M - 3000 psi	88,90 (3.50)	50,80 (2.00)	M12 1/2" UNC	1/8" BSP
F3	2 1/2" SAE/UNC - 3000 psi				1/8" NPT

Ports code	Flange connections - dual ports				
	Ports A and B †	C	D	E	G
F2	2 1/2" SAE/M - 3000 psi	88,90 (3.500)	50,80 (2.000)	M12	1/8" BSP
	2" SAE/M - 3000 psi	77,80 (3.062)	42,90 (1.688)		
F4	2 1/2" SAE/UNC - 3000 psi	88,90 (3.500)	50,80 (2.000)	1/2" UNC	1/8" NPT
	2" SAE/UNC - 3000 psi	77,80 (3.062)	42,90 (1.688)		

† Port A is 2 1/2".

OFRT630 Selection & Installation

Dimensions in mm (inch)

Housing Pressure Drop

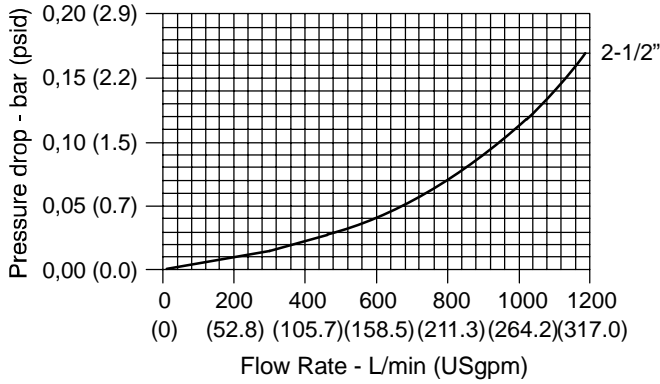

Bypass Valve Pressure Drop

Based on mineral oil with density of 0,86 kg/dm³.
 ΔP varies proportionally to density.

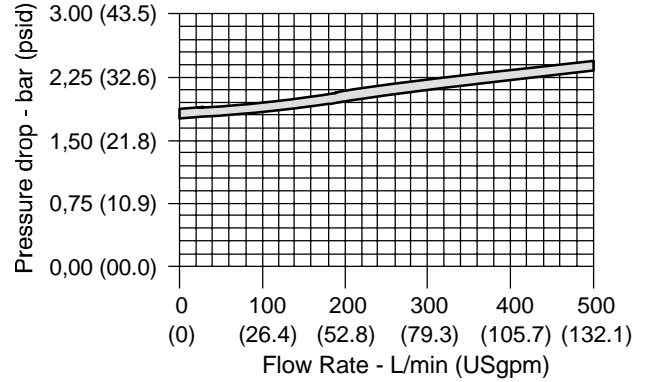

The following sizing recommendations are based on using mineral oil at 30 mm²/s (cSt) viscosity, maximum housing pressure drop 0,15 bar (2 psi), maximum clean element pressure drop 0,35 bar (5 psi). Refer to individual pressure drop curves, pages 31 through 34, to obtain filter assembly pressure drop information (ΔP Total = ΔP Housing + ΔP Element).

Micron code	Flow rate L/min (USgpm)	Bowl length code	Port size BSP NPT SAE	Weight with element and diffuser kg (lb)
A06 A10 P10 P25	220 (58.1) 320 (84.5) 320 (84.5) 320 (84.5)	1	2-1/2"	8,2 (18.1)
A06 A10 P10 P25	250 (66.0) 400 (105.7) 440 (116.2) 440 (116.2)	2	2-1/2"	8.7 (19.2)
A06 A10 P10 P25	280 (74.0) 440 (116.2) 540 (142.7) 540 (142.7)	3	2-1/2"	9,0 (19.8)
A06 A10 P10 P25	325 (85.9) 480 (126.8) 800 (211.3) 800 (211.3)	4	2-1/2"	9,5 (20.9)

OFRT850 Selection & Installation

Dimensions in mm (inch)

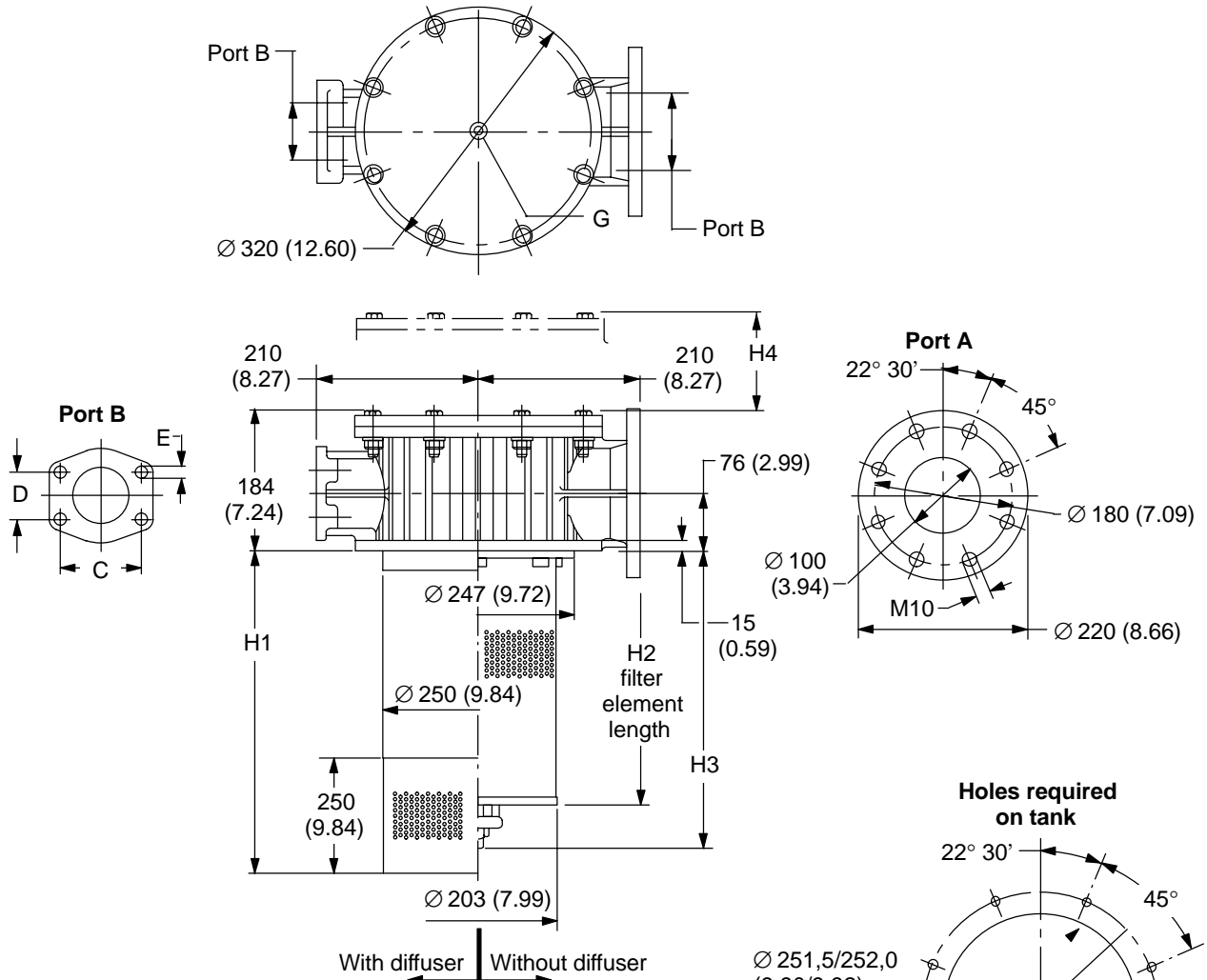

Bowl length code	Dimensions			
	H1	H2	H3	H4
1	420 (16.54)	330 (12.99)	388 (15.28)	520 (20.47)
2	635 (25.00)	545 (21.46)	603 (23.74)	740 (29.13)
3	915 (36.02)	825 (32.48)	883 (34.76)	1020 (40.16)
4	1180 (46.46)	1090 (42.91)	1148 (45.20)	1290 (50.79)

Ports code	Flange connections - dual ports				
	Ports A and B †	C	D	E	G
F1	DN 100 PN 10/16	-	-	-	1/8" BSP
	3" SAE/M - 3000 psi	106,38 (4.188)	61,93 (2.438)	M16	
F3	DN 100 PN 10/16	-	-	-	1/8" NPT
	3" SAE/UNC - 3000 psi	106,38 (4.188)	61,93 (2.438)	5/8" UNC	

† Port A is DN 100 PN 10/16.

OFRT850 Selection & Installation

Dimensions in mm (inch)

Housing Pressure Drop

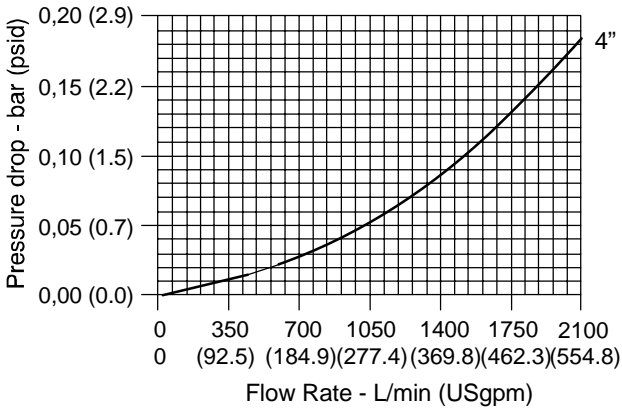

Bypass Valve Pressure Drop

Based on mineral oil with density of 0,86 kg/dm³.
 ΔP varies proportionally to density.

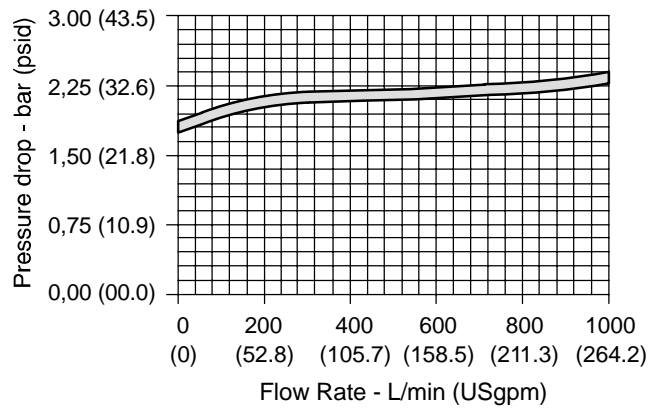

The following sizing recommendations are based on using mineral oil at 30 mm²/s (cSt) viscosity, maximum housing pressure drop 0,15 bar (2 psi), maximum clean element pressure drop 0,35 bar (5 psi). Refer to individual pressure drop curves, pages 31 through 34, to obtain filter assembly pressure drop information (ΔP Total = ΔP Housing + ΔP Element).

Micron code	Flow rate L/min (USgpm)	Bowl length code	Port size BSP NPT SAE	Weight with element and diffuser kg (lb)
A06 A10 P10 P25	450 (118.9) 650 (171.7) 800 (211.3) 800 (211.3)	1	4"	30 (66.14)
A06 A10 P10 P25	700 (184.9) 1000 (264.2) 1000 (264.2) 1000 (264.2)	2	4"	34 (74.96)
A06 A10 P10 P25	850 (224.5) 1200 (317.0) 1500 (396.3) 1500 (396.3)	3	4"	37 (81.57)
A06 A10 P10 P25	1000 (264.2) 1500 (396.3) 1800 (475.5) 1800 (475.5)	4	4"	41 (90.39)

OFRT Filter Element and Machining Dimensions

Dimensions in mm (inch)

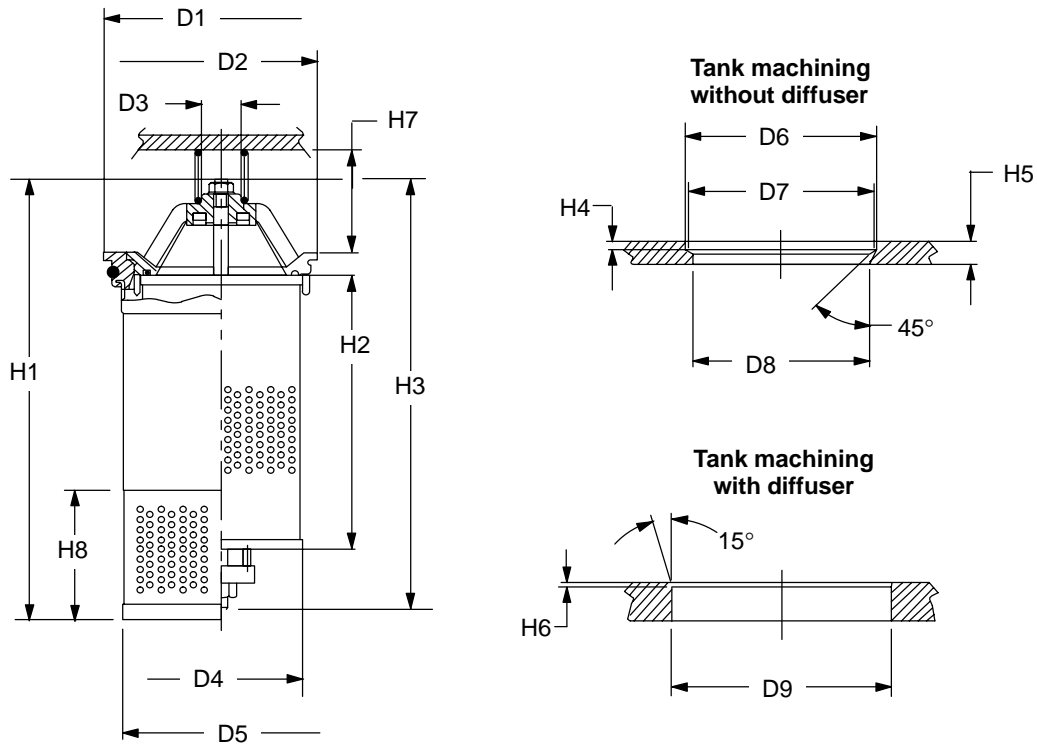

Filter size & bowl length	H1	H2	H3	H4	H5	H6	H7	H8	
100-1	245 (9.6)	106 (4.2)	180 (7.1)						
100-2	245 (9.6)	150 (5.9)	224 (8.8)	4 (0.16)	12 (0.5)	2,5 (0.1)	45 (1.8)	80 (3.1)	
100-3	295 (11.6)	200 (7.9)	274 (10.8)						
100-4	395 (15.6)	300 (11.8)	374 (14.7)						
250-1	307 (12.1)	140 (5.5)	250 (9.8)						
250-2	307 (12.1)	190 (7.5)	300 (11.8)	5 (0.20)	15 (0.6)	2,5 (0.1)	78 (3.1)	90 (3.5)	
250-3	377 (14.8)	260 (10.2)	370 (14.6)						
250-4	582 (22.9)	465 (18.3)	577 (22.7)						
630-1	355 (14.0)	210 (8.3)	341 (13.4)						
630-2	445 (17.5)	290 (11.4)	421 (16.6)	5 (0.20)	18 (0.7)	2,5 (0.1)	100 (3.9)	110 (4.3)	
630-3	545 (21.5)	390 (15.4)	521 (20.5)						
630-4	635 (25.0)	478 (18.8)	609 (24.0)						
850-1	530,5 (20.9)	330 (13.0)	515 (20.3)						
850-2	745,5 (29.4)	545 (21.5)	730 (28.7)	6 (0.24)	20 (0.8)	2,5 (0.1)	140 (5.5)	250 (9.8)	
850-3	1025,5 (40.4)	825 (32.5)	1010 (39.8)						
850-4	1290,5 (50.8)	1090 (42.9)	1275 (50.2)						
Filter size	D1	D2	D3	D4	D5	D6	D7	D8	D9
100	120 (4.7)	87 (3.4)	20 (0.8)	72 (2.8)	89 (3.5)	88 (3.5)	82,5 (3.2)	76 (3.0)	110,35/110,00 (4.34/4.33)
250	155 (6.1)	125,5 (4.9)	25 (1.0)	106 (4.2)	133 (5.2)	126 (5.0)	123,5 (4.9)	117 (4.6)	145,4/145,0 (5.72/5.71)
630	185 (7.3)	150 (5.9)	25 (1.0)	126 (5.0)	165 (6.5)	151 (5.9)	149 (5.9)	139 (5.5)	178,4/178,0 (7.02/7.01)
850	260 (10.2)	230 (9.1)	40 (1.6)	203 (8.0)	245 (9.6)	231 (9.1)	227 (8.9)	217 (8.5)	251,02/250,5 (9.88/9.86)

OFRT "A" Elements Pressure Drop

Based on mineral oil with a kinematic viscosity of 30 mm²/s (cSt).
 ΔP varies proportionally to kinematic viscosity.

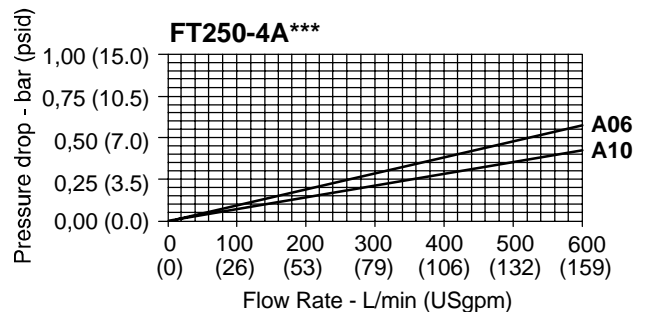
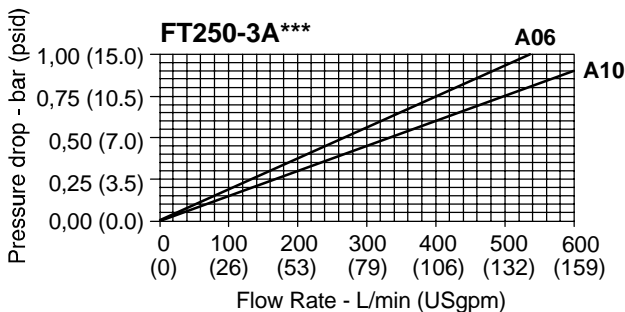
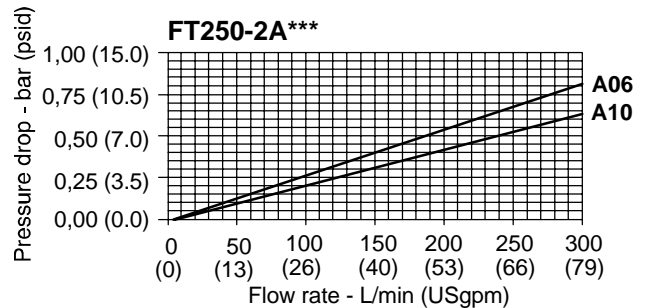
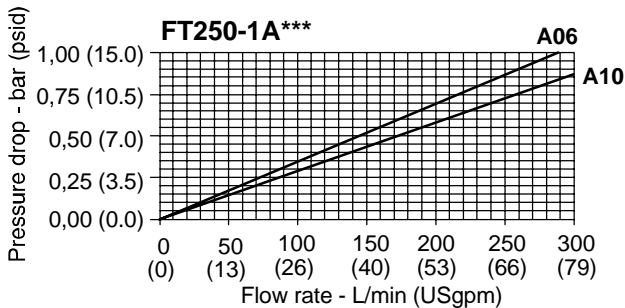
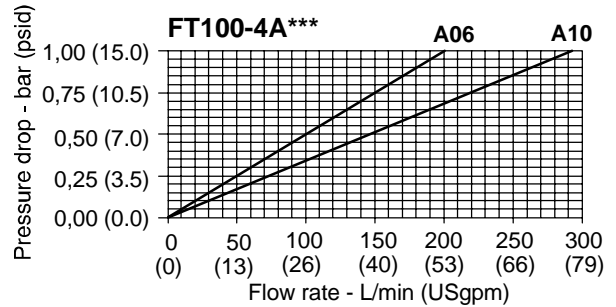
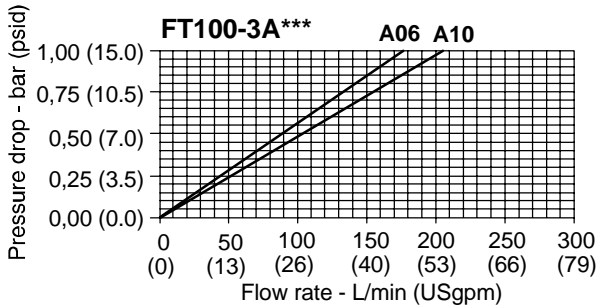
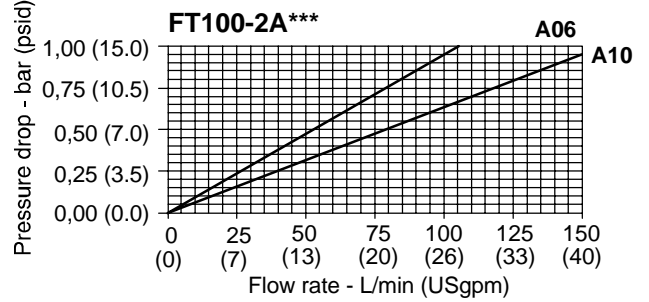
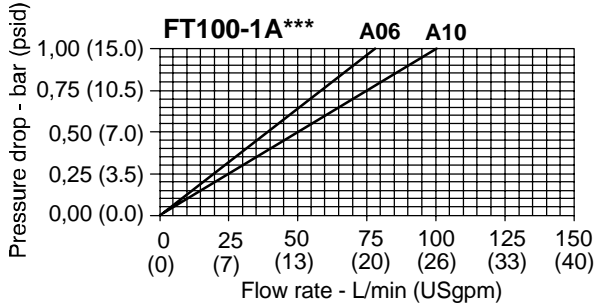

OFRT "A" Elements Pressure Drop

Based on mineral oil with a kinematic viscosity of 30 mm²/s (cSt).
 ΔP varies proportionally to kinematic viscosity.

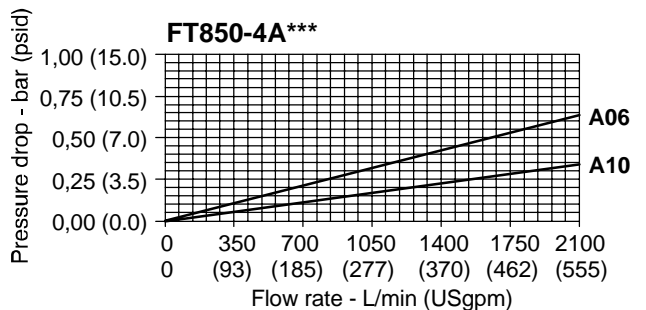
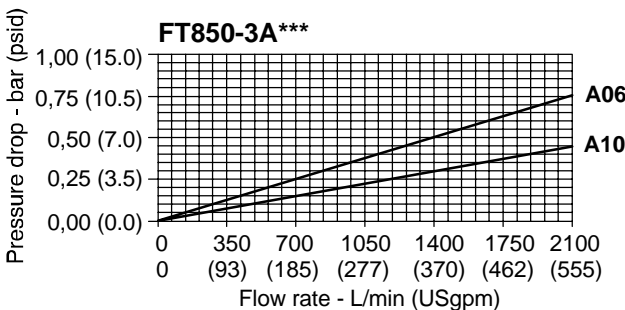
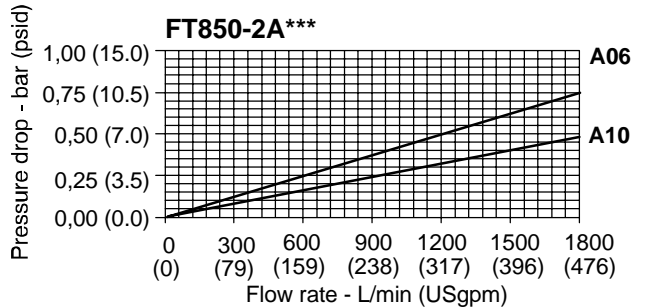
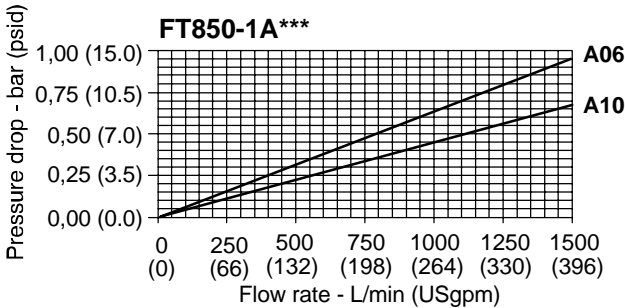
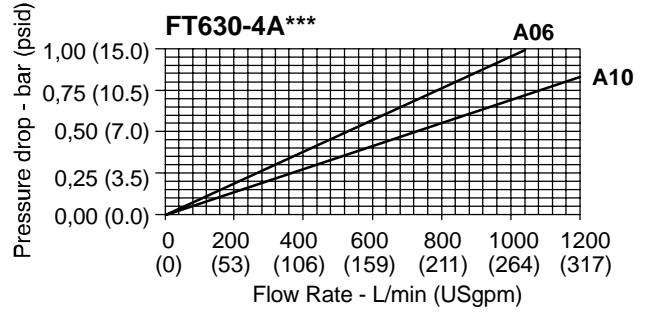
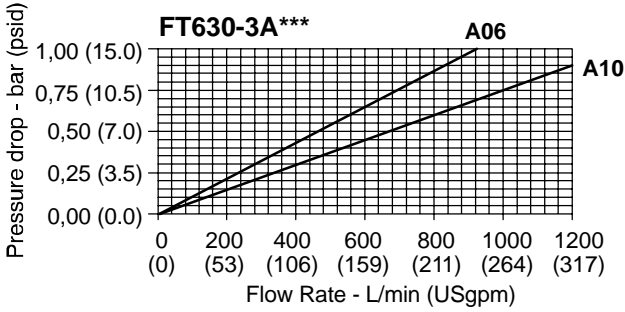
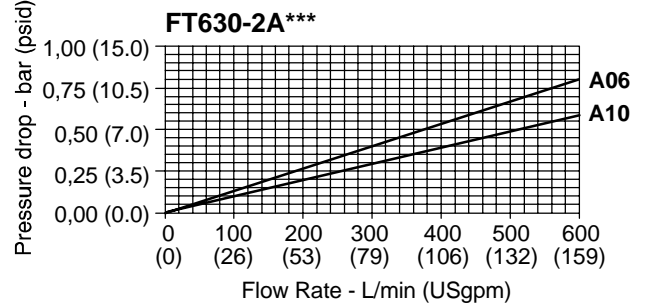
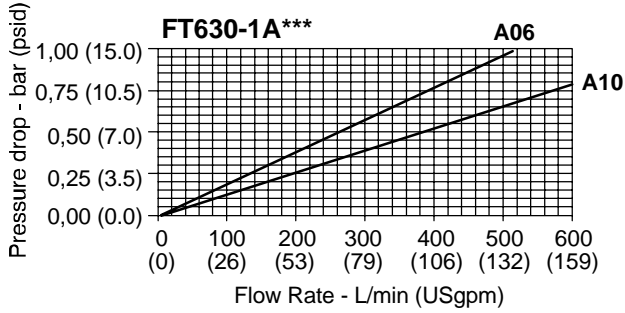

OFRT "P" Elements Pressure Drop

Based on mineral oil with a kinematic viscosity of 30 mm²/s (cSt).
 ΔP varies proportionally to kinematic viscosity.

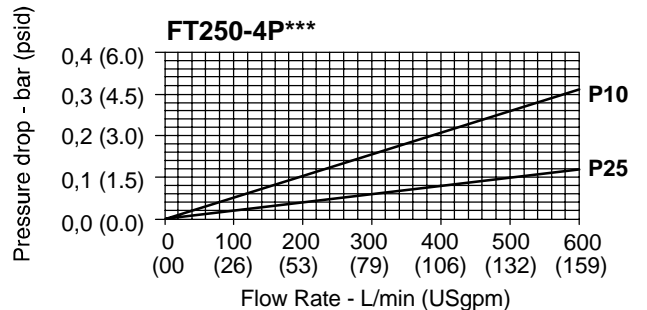
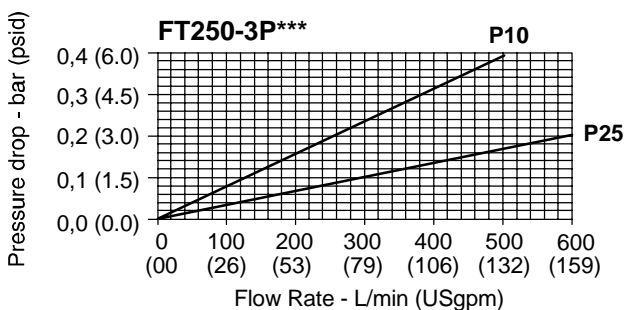
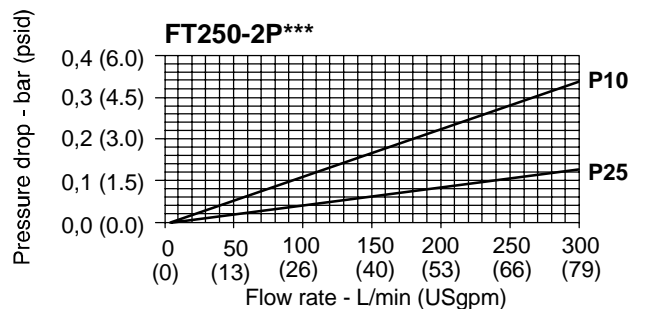
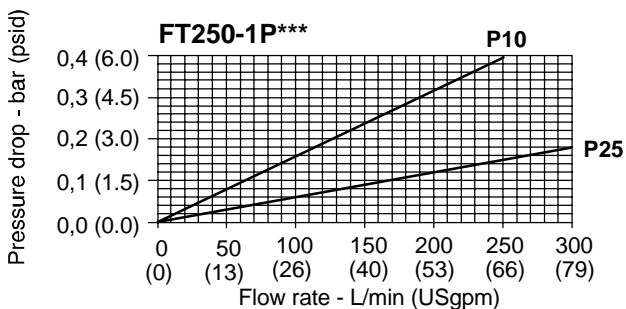
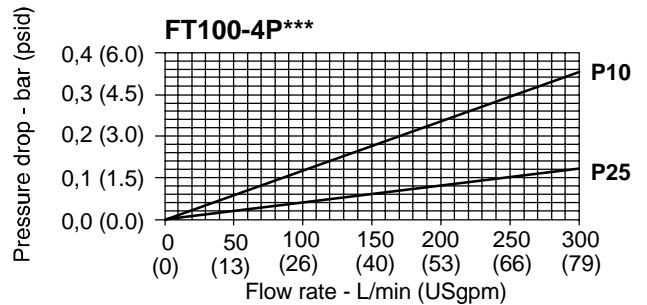
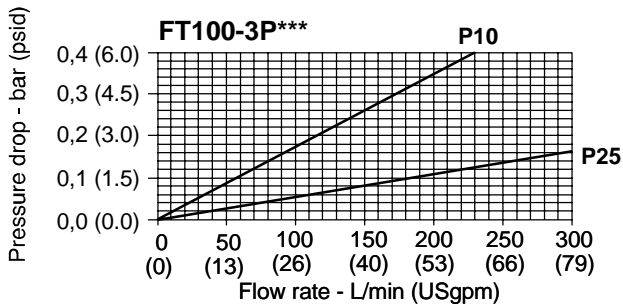
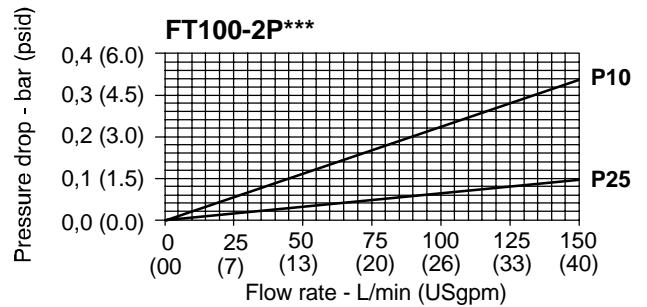
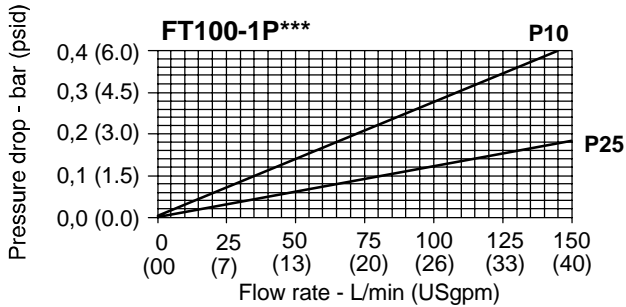

OFRT "P" Elements Pressure Drop

Based on mineral oil with a kinematic viscosity of 30 mm²/s (cSt).
 ΔP varies proportionally to kinematic viscosity.

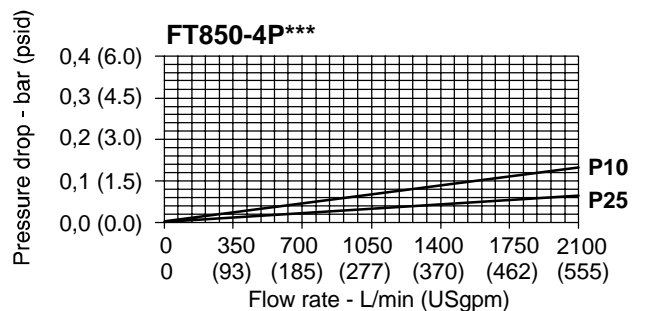
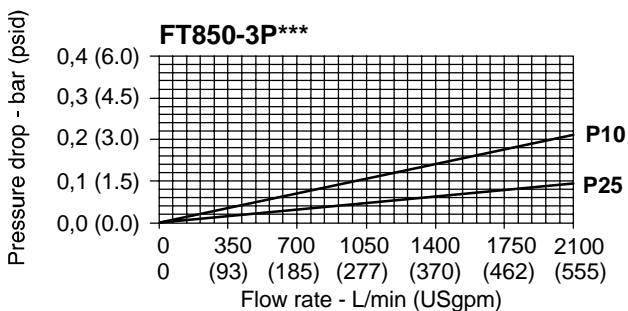
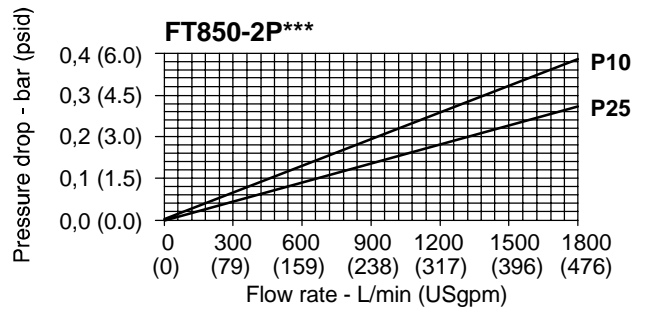
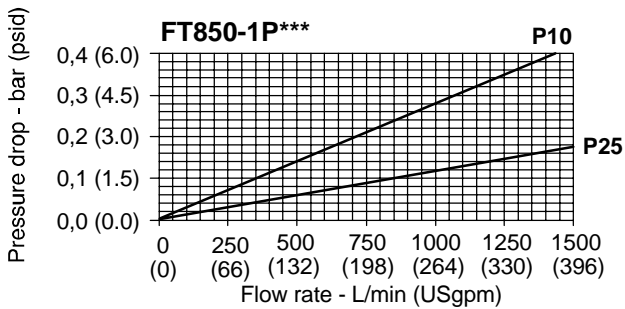
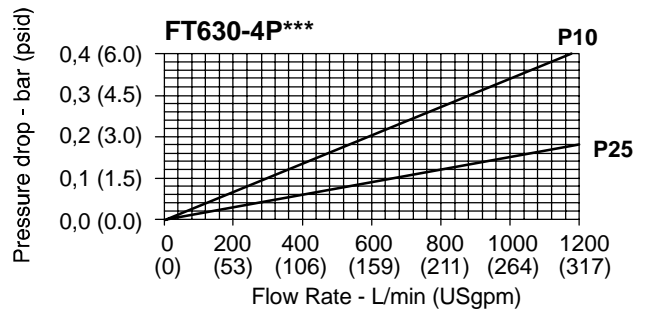
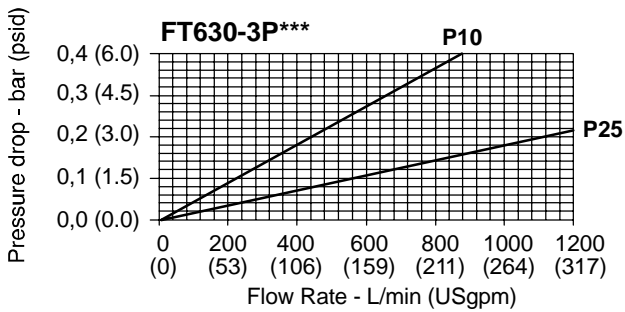
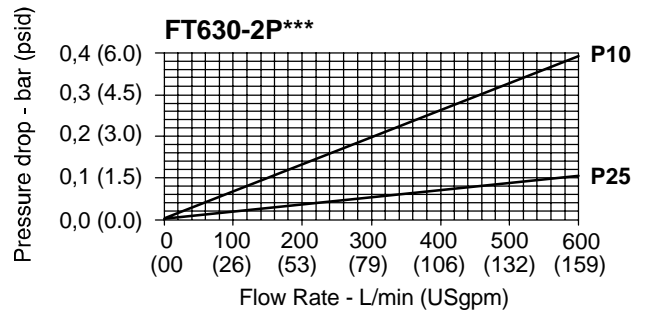
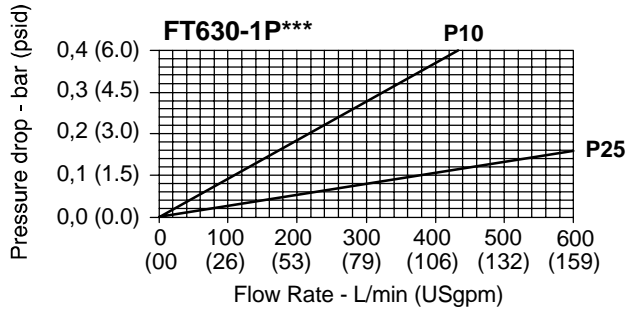

Contamination Control

The Systemic Approach to Contamination Control

For a hydraulic or oil lubricated machine, the development of a target cleanliness level and the plan to achieve it is as much a part of system design as the selection of the pump, valves, actuators or bearings. Proper selection and placement of contamination control devices in a system to attain the targeted cleanliness eliminates up to 80% of hydraulic system failures.

Additionally, the system cleanliness approach assures the user of the hydraulic system a cost effective approach to contamination control that allows the price of the filters and elements to be quickly recovered by the savings of improved performance, increased component life, increased oil life, increased uptime and fewer repairs.

To stress the interacting relationship between component design, system design, filter performance and filter replacement, Vickers has named our approach to filters and filtration "Vickers Guide to Systemic Contamination ControlSM." This approach has three steps:

- **Set a target cleanliness level.**

Using the Vickers Target Cleanliness Worksheet (#578), it is easy to determine the target ISO Cleanliness Level. This target is based on the application's components and system dynamics.

- **Select filters and filter replacements to achieve the target.**

The Systemic Approach to Contamination Control (#561) offers options to consider when selecting our high efficiency filters, such as the options available for location and sizing of filters in the system to achieve a specified target cleanliness level.

- **Monitor the system to ensure the target is maintained.**

The Vickers Fluid Analysis Laboratory and the Target-Pro Portable Particle Counter report the fluid cleanliness in the three digit ISO code cleanliness level format, corresponding to the 2, 5 and 15 micron particle counts. From this information, it is possible to determine whether the system has the clean fluid it needs for long, dependable operation.

Supporting Literature

- Vickers Reservoir Vent Filters #5027/EN/0196/P
- Vickers Differential Pressure Indicator Guide #580
- Vickers CleanCart Portable Filtering Transfer Cart #601
- Vickers Fluid Analysis Service #588
- Vickers Fluid Analysis Technical Brochure #664
- Vickers Guide to Alternative Fluids #579
- Vickers Return in Investment: ProActive Maintenance #707
- The Systemic Approach to Contamination Control #561
- Vickers Target Cleanliness Worksheet #578
- Vickers Target-Pro Particle Counter #709
- Vickers Water Contamination Solutions #5026/EN/0196/A
- ANSI Systems Standards for Stationary Industrial Machinery #675

Алматы (7273)495-231
Ангарск (3955)60-70-56
Архангельск (8182)63-90-72
Астрахань (8512)99-46-04
Барнаул (3852)73-04-60
Белгород (4722)40-23-64
Благовещенск (4162)22-76-07
Брянск (4832)59-03-52
Владивосток (423)249-28-31
Владикавказ (8672)28-90-48
Владимир (4922)49-43-18
Волгоград (844)278-03-48
Вологда (8172)26-41-59
Воронеж (473)204-51-73
Екатеринбург (343)384-55-89

Иваново (4932)77-34-06
Ижевск (3412)26-03-58
Иркутск (395)279-98-46
Казань (843)206-01-48
Калининград (4012)72-03-81
Калуга (4842)92-23-67
Кемерово (3842)65-04-62
Киров (8332)68-02-04
Коломна (4966)23-41-49
Кострома (4942)77-07-48
Краснодар (861)203-40-90
Красноярск (391)204-63-61
Курск (4712)77-13-04
Курган (3522)50-90-47
Липецк (4742)52-20-81

Магнитогорск (3519)55-03-13
Москва (495)268-04-70
Мурманск (8152)59-64-93
Набережные Челны (8552)20-53-41
Нижний Новгород (831)429-08-12
Новокузнецк (3843)20-46-81
Ноябрьск (3496)41-32-12
Новосибирск (383)227-86-73
Омск (3812)21-46-40
Орел (4862)44-53-42
Оренбург (3532)37-68-04
Пенза (8412)22-31-16
Петрозаводск (8142)55-98-37
Псков (8112)59-10-37
Пермь (342)205-81-47

Ростов-на-Дону (863)308-18-15
Рязань (4912)46-61-64
Самара (846)206-03-16
Санкт-Петербург (812)309-46-40
Саратов (845)249-38-78
Севастополь (8692)22-31-93
Саранск (8342)22-96-24
Симферополь (3652)67-13-56
Смоленск (4812)29-41-54
Сочи (862)225-72-31
Ставрополь (8652)20-65-13
Сургут (3462)77-98-35
Сыктывкар (8212)25-95-17
Тамбов (4752)50-40-97
Тверь (4822)63-31-35

Тольятти (8482)63-91-07
Томск (3822)98-41-53
Тула (4872)33-79-87
Тюмень (3452)66-21-18
Ульяновск (8422)24-23-59
Улан-Удэ (3012)59-97-51
Уфа (347)229-48-12
Хабаровск (4212)92-98-04
Чебоксары (8352)28-53-07
Челябинск (351)202-03-61
Череповец (8202)49-02-64
Чита (3022)38-34-83
Якутск (4112)23-90-97
Ярославль (4852)69-52-93

Россия +7(495)268-04-70

Казахстан +7(7172)727-132

Киргизия +996(312)96-26-47

<https://vickers.nt-rt.ru> || vsh@nt-rt.ru