

Алматы (7273)495-231
 Ангарск (3955)60-70-56
 Архангельск (8182)63-90-72
 Астрахань (8512)99-46-04
 Барнаул (3852)73-04-60
 Белгород (4722)40-23-64
 Благовещенск (4162)22-76-07
 Брянск (4832)59-03-52
 Владивосток (423)249-28-31
 Владикавказ (8672)28-90-48
 Владимир (4922)49-43-18
 Волгоград (844)278-03-48
 Вологда (8172)26-41-59
 Воронеж (473)204-51-73
 Екатеринбург (343)384-55-89

Иваново (4932)77-34-06
 Ижевск (3412)26-03-58
 Иркутск (395)279-98-46
 Казань (843)206-01-48
 Калининград (4012)72-03-81
 Калуга (4842)92-23-67
 Кемерово (3842)65-04-62
 Киров (8332)68-02-04
 Коломна (4966)23-41-49
 Кострома (4942)77-07-48
 Краснодар (861)203-40-90
 Красноярск (391)204-63-61
 Курск (4712)77-13-04
 Курган (3522)50-90-47
 Липецк (4742)52-20-81

Магнитогорск (3519)55-03-13
 Москва (495)268-04-70
 Мурманск (8152)59-64-93
 Набережные Челны (8552)20-53-41
 Нижний Новгород (831)429-08-12
 Новокузнецк (3843)20-46-81
 Ноябрьск (3496)41-32-12
 Новосибирск (383)227-86-73
 Омск (3812)21-46-40
 Орел (4862)44-53-42
 Оренбург (3532)37-68-04
 Пенза (8412)22-31-16
 Петрозаводск (8142)55-98-37
 Псков (8112)59-10-37
 Пермь (342)205-81-47

Ростов-на-Дону (863)308-18-15
 Рязань (4912)46-61-64
 Самара (846)206-03-16
 Санкт-Петербург (812)309-46-40
 Саратов (845)249-38-78
 Севастополь (8692)22-31-93
 Саранск (8342)22-96-24
 Симферополь (3652)67-13-56
 Смоленск (4812)29-41-54
 Сочи (862)225-72-31
 Ставрополь (8652)20-65-13
 Сургут (3462)77-98-35
 Сыктывкар (8212)25-95-17
 Тамбов (4752)50-40-97
 Тверь (4822)63-31-35

Тольятти (8482)63-91-07
 Томск (3822)98-41-53
 Тула (4872)33-79-87
 Тюмень (3452)66-21-18
 Ульяновск (8422)24-23-59
 Улан-Удэ (3012)59-97-51
 Уфа (347)229-48-12
 Хабаровск (4212)92-98-04
 Чебоксары (8352)28-53-07
 Челябинск (351)202-03-61
 Череповец (8202)49-02-64
 Чита (3022)38-34-83
 Якутск (4112)23-90-97
 Ярославль (4852)69-52-93

Россия +7(495)268-04-70

Казахстан +7(7172)727-132

Киргизия +996(312)96-26-47

<https://vickers.nt-rt.ru> || vsh@nt-rt.ru

LV4P Series Filters

Flows to 330 L/min
(87 USgpm)

Pressures to 100 bar
(1500 PSI)

Features and Benefits

- Designed to comply with ANSI specifications and ISO cleanliness standards.
- Visual, electrical, and electrical indicators with lamp options for system design flexibility.
- Fully serviceable without tools.
- Zero leak by-pass valve construction.
- Wide range of element lengths for maximum design flexibility.
- High efficiency replacement elements in standard configurations (C-Pak) to meet Target Cleanliness Levels.
- High collapse elements available for non-bypass applications.

DESIGN SPECIFICATIONS

Rated flow:	Length 6 Length 7	160 L/min (42 USgpm) 330 L/min (87 USgpm)
Housing & Element Compatibility:	Compatible with most petroleum oil, oil-in-water and water-in-oil fluids. Optional seals available for phosphate esters.	
Temp range:	-40°C to +121°C (-40°F to +250°F)	
Pressure rating:	Operating Proof Burst Fatigue	100 bar (1500 PSI) 258 bar (3750 PSI) 545 bar (7902 PSI) 100 bar (1500 PSI)
Material:	Head Bowl	Aluminum Aluminum
Dry weight: (Approximate)	Length 6 Length 7	3.7 kg (8.2 lbs) 8.2 kg (18.1 lbs)

VICKERS®

Dimensions

LV4P Housing

mm (inch)

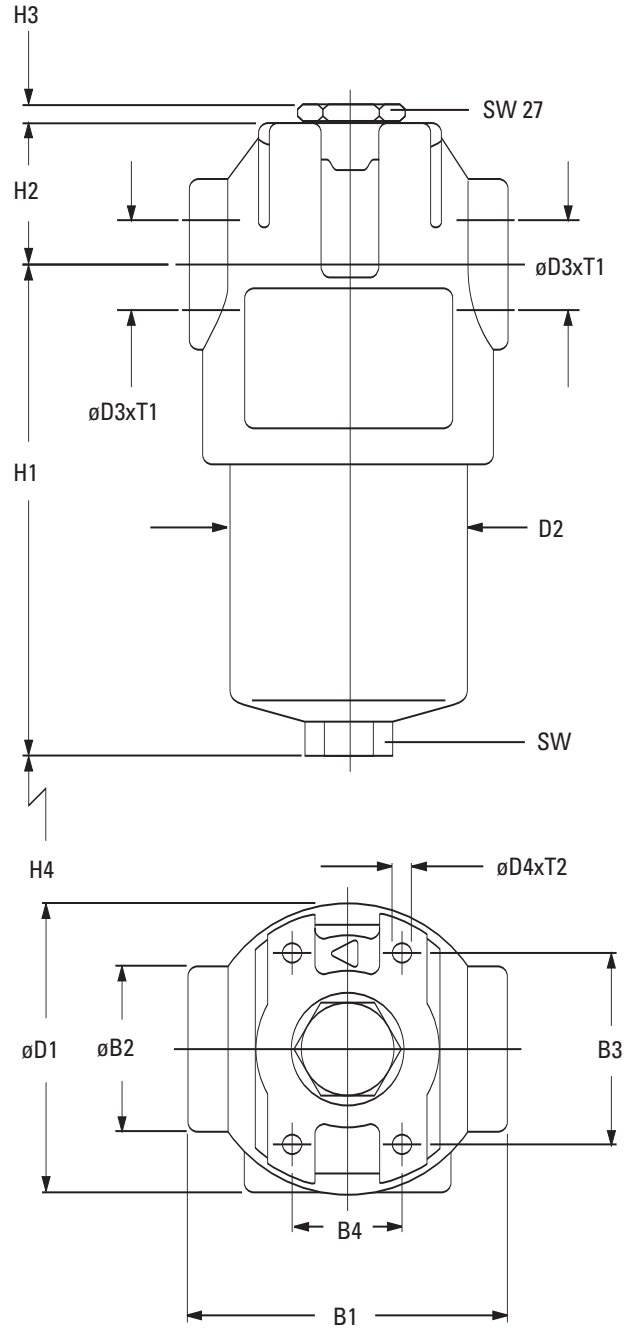

	Size B1	B2	B3	B4	D1	D2	D3	D4	H1	H2	H3	H4	SW	T1	T2
Length 5	127	65	85	35	115	95	SAE 20	3/8-24	193	47	6	85	32	21	14
Length 7	160	85	115	60	157	130	SAE 24	1/2-20	254	51	6	95	36	23	17

measurements are in millimeters

Model Codes

LV4P Series Filter Assembly Model Code

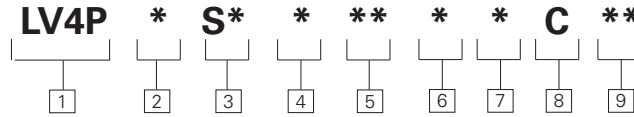

Sample model code:
LV4P-1-SC-4-LN-B-5-C-05

1 Filter Series
LV4P - Series

2 Element Collapse Rating
1 - 250 PSI Low Collapse
4 - 3000 PSI High Collapse

3 Port options
Length 6:
SC - 1.625 - 12UN SAE-20 Str. thd.
(1 1/4" tube)
Length 7:
SD - 1.875 - 12UN SAE-24 Str. thd.
(1 1/2" tube)

4 Valve options
1 - Non-Bypass
4 - Bypass set at 43 PSI
cracking pressure
6 - Bypass set at 90 PSI
cracking pressure

5 Indicator options
First Designator - Indicator Type
A - Visual 70 PSI
J - No Indicator (plug)
L - Visual 30 PSI
R - Electrical 30 PSI
U - Electrical 70 PSI

Second Designator - Electrical Receptical
B - Brad Harrison
H - Hirshman
J - Hirshman with 24 volt light
K - Hirshman with 115 volt light
L - Hirshman with 230 volt light
N - No Connector - use with
visual indicators and "J"

6 Seal material
B - Buna-N
V - Viton-A

Viton is a registered trademark of E.I. DuPont

7 Element length
5 - 147mm (5.8") 247mm (9.73")
7 - 180mm (7.09") 312mm (12.29")

8 Element construction
C - Standard Construction

9 Fluid cleanliness rating

Code level	Target fluid cleanliness
03	16/14/12 or better
05	18/16/14 or better
10	20/18/15 or better
20	22/19/16 or better

The table assumes limited ingress/single pass of pump flow through element. For detailed assistance, see "The Systemic Approach to Contamination Control" or contact your local Eaton representative.

B0513 Series Replacement Filter Element Model Codes

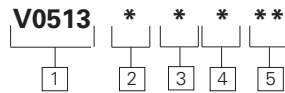

Sample model code:
V0513-B-5-C-05

1 Filter element
V0513 - For use with LV4P series housings

2 Seal material
B - Buna-N
V - Viton-A
Viton is a registered trademark of E.I. DuPont

3 Element length
mm (inch)
5 - 147 (5.8)
7 - 180 (7.09)

4 Element construction
C - C-Pak (grade 3, 5, 10, 20)
H - H-Pak (grade 3, 5, 10)

5 Fluid cleanliness ratings

Code	Target fluid cleanliness level
03	16/14/12 or better
05	18/16/14 or better
10	20/18/15 or better
20	22/19/16 or better

The table assumes limited ingress/single pass of pump flow through element. For detailed assistance, see "The Systemic Approach to Contamination Control" or contact your local Eaton representative.

DESIGN SPECIFICATIONS

Rated flow:	Length 6 Length 7	160 L/min (42 USgpm) 330 L/min (87 USgpm)
Housing & Element Compatibility:	Compatible with most petroleum oil, oil-in-water and water-in-oil fluids. Optional seals available for phosphate esters.	
Temp range:	-40°C to +121°C (-40°F to +250°F)	
Construction:	C-Pak or H Pak	

LV4P Series Flow Data

Flow versus pressure drop:
150 SUS (32 cSt) oil with
specific gravity of <0.9

mm (inch)

Housing Curves

LV4P*****5 Housing

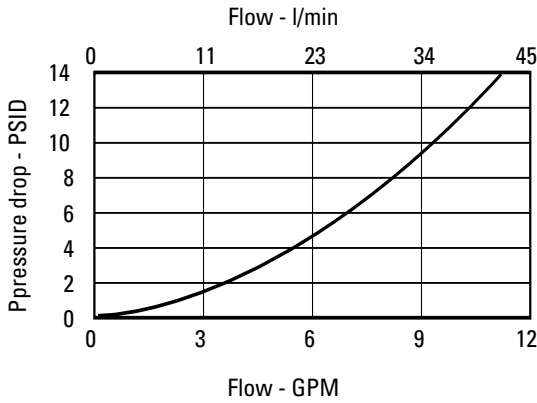

LV4P*****7 Housing

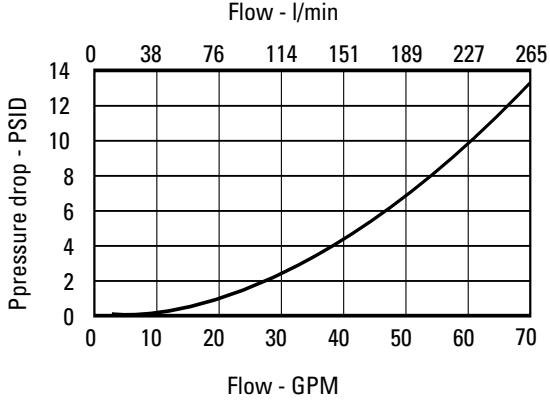

Element Flow Curves

LV4P*****5

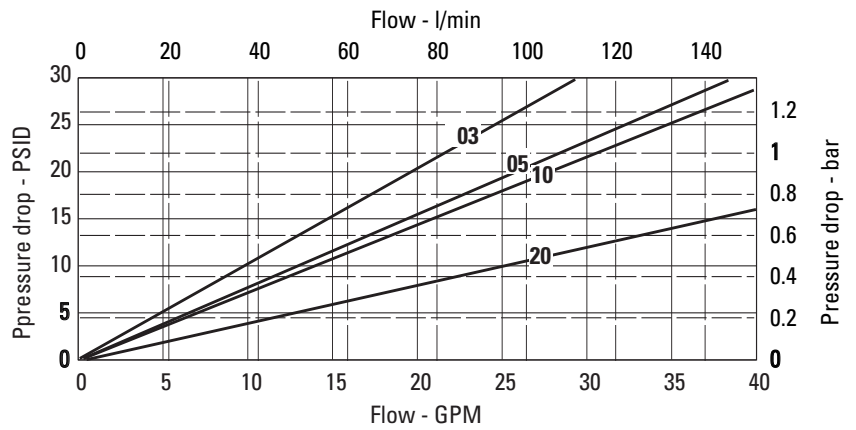

LV4P*****7

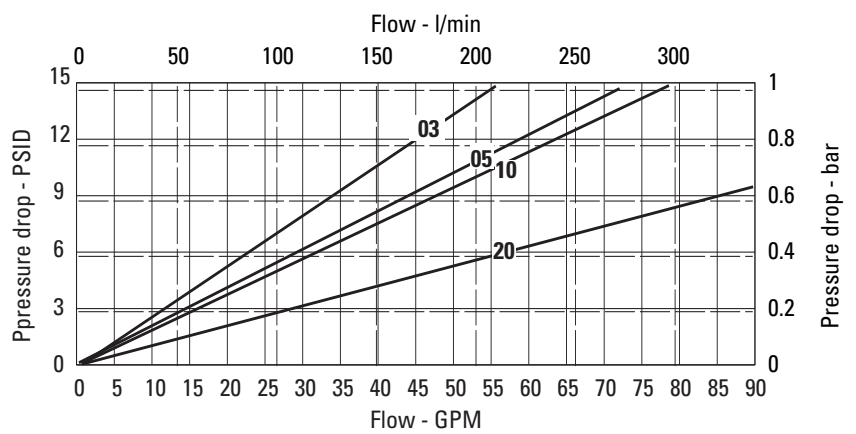

Алматы (7273)495-231
Ангарск (3955)60-70-56
Архангельск (8182)63-90-72
Астрахань (8512)99-46-04
Барнаул (3852)73-04-60
Белгород (4722)40-23-64
Благовещенск (4162)22-76-07
Брянск (4832)59-03-52
Владивосток (423)249-28-31
Владикавказ (8672)28-90-48
Владимир (4922)49-43-18
Волгоград (844)278-03-48
Вологда (8172)26-41-59
Воронеж (473)204-51-73
Екатеринбург (343)384-55-89

Иваново (4932)77-34-06
Ижевск (3412)26-03-58
Иркутск (395)279-98-46
Казань (843)206-01-48
Калининград (4012)72-03-81
Калуга (4842)92-23-67
Кемерово (3842)65-04-62
Киров (8332)68-02-04
Коломна (4966)23-41-49
Кострома (4942)77-07-48
Краснодар (861)203-40-90
Красноярск (391)204-63-61
Курск (4712)77-13-04
Курган (3522)50-90-47
Липецк (4742)52-20-81

Магнитогорск (3519)55-03-13
Москва (495)268-04-70
Мурманск (8152)59-64-93
Набережные Челны (8552)20-53-41
Нижний Новгород (831)429-08-12
Новокузнецк (3843)20-46-81
Ноябрьск (3496)41-32-12
Новосибирск (383)227-86-73
Омск (3812)21-46-40
Орел (4862)44-53-42
Оренбург (3532)37-68-04
Пенза (8412)22-31-16
Петрозаводск (8142)55-98-37
Псков (8112)59-10-37
Пермь (342)205-81-47

Ростов-на-Дону (863)308-18-15
Рязань (4912)46-61-64
Самара (846)206-03-16
Санкт-Петербург (812)309-46-40
Саратов (845)249-38-78
Севастополь (8692)22-31-93
Саранск (8342)22-96-24
Симферополь (3652)67-13-56
Смоленск (4812)29-41-54
Сочи (862)225-72-31
Ставрополь (8652)20-65-13
Сургут (3462)77-98-35
Сыктывкар (8212)25-95-17
Тамбов (4752)50-40-97
Тверь (4822)63-31-35

Тольятти (8482)63-91-07
Томск (3822)98-41-53
Тула (4872)33-79-87
Тюмень (3452)66-21-18
Ульяновск (8422)24-23-59
Улан-Удэ (3012)59-97-51
Уфа (347)229-48-12
Хабаровск (4212)92-98-04
Чебоксары (8352)28-53-07
Челябинск (351)202-03-61
Череповец (8202)49-02-64
Чита (3022)38-34-83
Якутск (4112)23-90-97
Ярославль (4852)69-52-93

Россия +7(495)268-04-70

Казахстан +7(7172)727-132

Киргизия +996(312)96-26-47

<https://vickers.nt-rt.ru> || vsh@nt-rt.ru