

Алматы (7273)495-231  
Ангарск (3955)60-70-56  
Архангельск (8182)63-90-72  
Астрахань (8512)99-46-04  
Барнаул (3852)73-04-60  
Белгород (4722)40-23-64  
Благовещенск (4162)22-76-07  
Брянск (4832)59-03-52  
Владивосток (423)249-28-31  
Владикавказ (8672)28-90-48  
Владимир (4922)49-43-18  
Волгоград (844)278-03-48  
Вологда (8172)26-41-59  
Воронеж (473)204-51-73  
Екатеринбург (343)384-55-89

Иваново (4932)77-34-06  
Ижевск (3412)26-03-58  
Иркутск (395)279-98-46  
Казань (843)206-01-48  
Калининград (4012)72-03-81  
Калуга (4842)92-23-67  
Кемерово (3842)65-04-62  
Киров (8332)68-02-04  
Коломна (4966)23-41-49  
Кострома (4942)77-07-48  
Краснодар (861)203-40-90  
Красноярск (391)204-63-61  
Курск (4712)77-13-04  
Курган (3522)50-90-47  
Липецк (4742)52-20-81

Магнитогорск (3519)55-03-13  
Москва (495)268-04-70  
Мурманск (8152)59-64-93  
Набережные Челны (8552)20-53-41  
Нижний Новгород (831)429-08-12  
Новокузнецк (3843)20-46-81  
Ноябрьск (3496)41-32-12  
Новосибирск (383)227-86-73  
Омск (3812)21-46-40  
Орел (4862)44-53-42  
Оренбург (3532)37-68-04  
Пенза (8412)22-31-16  
Петрозаводск (8142)55-98-37  
Псков (8112)59-10-37  
Пермь (342)205-81-47

Ростов-на-Дону (863)308-18-15  
Рязань (4912)46-61-64  
Самара (846)206-03-16  
Санкт-Петербург (812)309-46-40  
Саратов (845)249-38-78  
Севастополь (8692)22-31-93  
Саранск (8342)22-96-24  
Симферополь (3652)67-13-56  
Смоленск (4812)29-41-54  
Сочи (862)225-72-31  
Ставрополь (8652)20-65-13  
Сургут (3462)77-98-35  
Сыктывкар (8212)25-95-17  
Тамбов (4752)50-40-97  
Тверь (4822)63-31-35

Тольятти (8482)63-91-07  
Томск (3822)98-41-53  
Тула (4872)33-79-87  
Тюмень (3452)66-21-18  
Ульяновск (8422)24-23-59  
Улан-Удэ (3012)59-97-51  
Уфа (347)229-48-12  
Хабаровск (4212)92-98-04  
Чебоксары (8352)28-53-07  
Череповец (8202)49-02-64  
Чита (3022)38-34-83  
Якутск (4112)23-90-97  
Ярославль (4852)69-52-93

Россия +7(495)268-04-70

Казахстан +7(7172)727-132

Киргизия +996(312)96-26-47

<https://vickers.nt-rt.ru> || [vsh@nt-rt.ru](mailto:vsh@nt-rt.ru)

Vickers®

## Accessories

# Accessories for Hydraulic Systems



**VICKERS**

Rev. 04/99

# Introduction

---

Vickers accessories are designed to facilitate the installation, or augment the start-up or performance, of Vickers primary components and systems on industrial and mobile machinery. The accessories are also compatible with other product brands.

## Table of Contents

---

- Air Bleed Valves ..... 3
- Ball Shuttle Valves ..... 4
- Bolt Kits ..... 5
- Flanges
  - SAE 4-bolt ..... 9
  - Square Flanges and Unions ..... 11
- Foot Bracket Kits for Pumps and Motors ..... 15
- Needle Valves ..... 16
- Angle and Globe Valves, Needle and Plug Types ..... 18
- Oil Coolers
  - Air Type ..... 20
  - Water Type ..... 26
- Pressure Gages
  - Diaphragm Type ..... 32
  - Bourdon Tube ..... 33
  - Spring-loaded ..... 35
- Reservoir Filler-breather ..... 36
- Vacuum and Pressure Switches ..... 37

# Air Bleed Valves

## Usage and Operation

This valve may be used to simplify pump priming at start-up in a blocked circuit, or to remove air trapped in the system.

When used to facilitate priming, the valve is teed into the pump outlet, as close to the pump as possible, and upstream of the balance of the circuit.

It lets air pass at low pressure (start-up) to the drain, and shuts off oil flow at pressures above 0,83 bar (12 psi).

The valve will pass 7,6 L/min (2 USgpm) just before shutting off. Therefore, it is recommended only for systems with a minimum supply that exceeds 7,6 L/min (2 USgpm.)

When used to remove air trapped in the system, the valve should be placed at the highest point of the circuit

## Pressure and Weight

Maximum pressure is 210 bar (3000 psi). Approximate weight is 0,34 kg (12 oz).

## Dimensions in Millimeters (Inches)

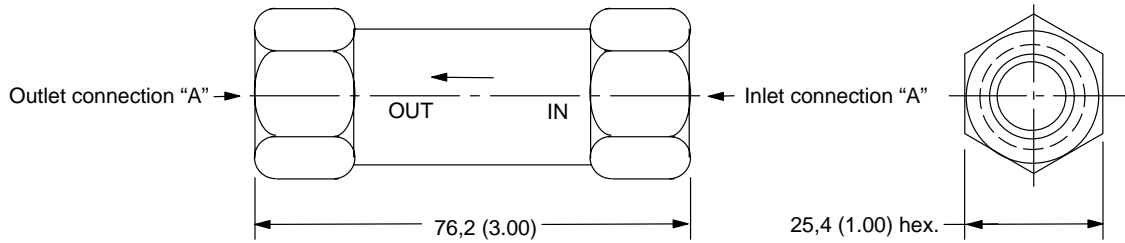

Model Number	Connection "A"
ABT-03-10	3/8 NPTF pipe thread
ABS-12-10	.750-16 UNF-2B straight thread for .50 O.D. tube

## Typical Pump Priming Installation

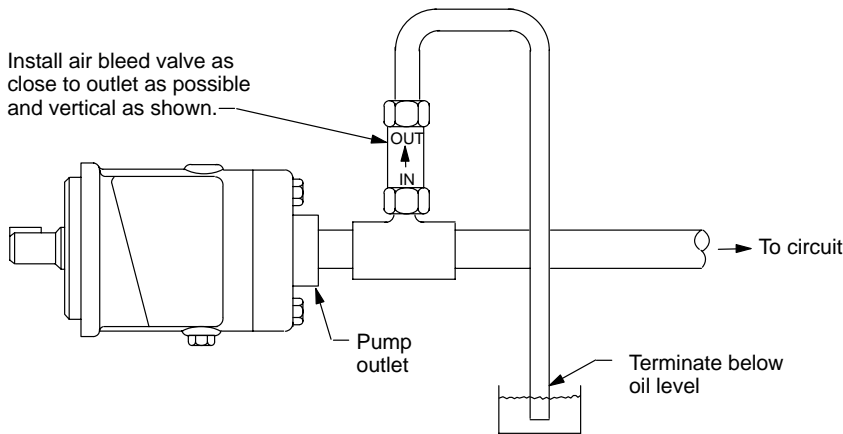

## Air Bleed Valve Symbol

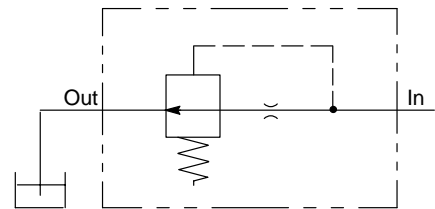

**Important:** Terminate return line to reservoir below oil level.

# Ball Shuttle Valve

## General Data

The ball shuttle valve is used in a system to select the higher of two pressures for pilot use. The body is made of carbon steel, the ball of stainless steel, and the seals of fluorocarbon.

## Ratings

Maximum operating pressure is 345 bar (5000 psig). The operating temperature range is  $-40^{\circ}$  to  $149^{\circ}$  C ( $-40^{\circ}$  to  $300^{\circ}$  F).

## Fluids

All commonly used hydraulic fluids may be used.

## Weight

4,26 kg (1.125 lb)

## Dimensions in Millimeters (Inches)

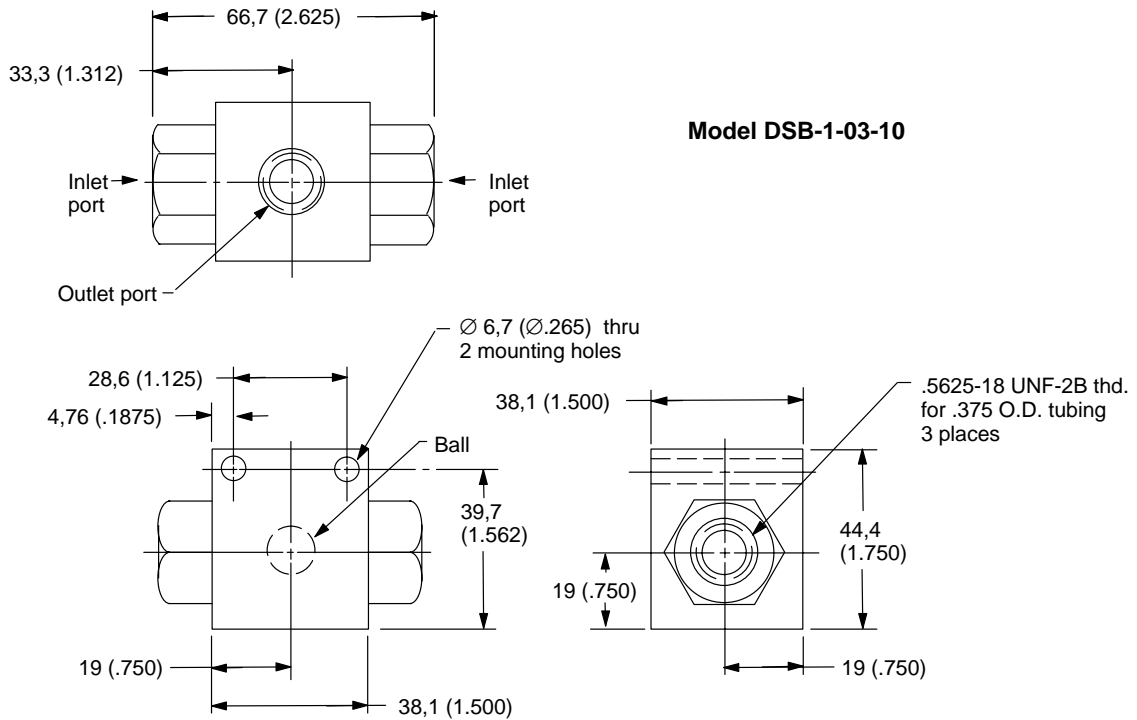

## Pressure Drop Versus Flow

33 cSt (150 SUS) Fluid Viscosity

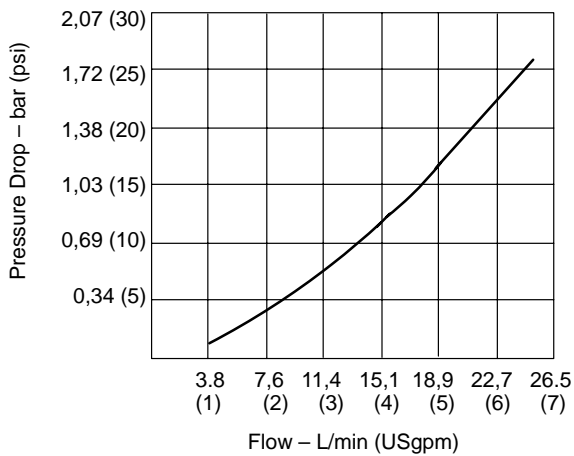

## Standard Graphical Symbol for Fluid Power Diagrams

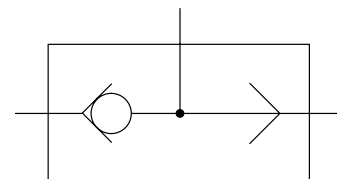

# Bolt Kits

## General Data

Vickers bolt kits are used for mounting valves to a subplate or manifold. All bolts meet SAE recommended standards. To determine which bolt kit is appropriate for a specific

valve, seemounting bolt recommendations in individual valve application catalogs.

## Ordering Information

Provide bolt kit numbers and assembly numbers when ordering.

Bolt Kit Number	Bolt Quantity	Thread Size and Length	Assembly Number
BK255654	4	1/4-20 x 3.50"	255654
BK255657	4	1/4-20 x 6"	255657
BK255659	4	1/4-20 x 8.50"	255659
BK255664	4	1/4-20 x 6.50"	255664
BK255667	4	1/4-20 x 7"	255667
BK255668	6	1/2-13 x 8.75"	255668
BK255669	6	1/2-13 x 10"	255669
BK255670	6	1/2-13 x 9.50"	255670
BK255671	6	1/2-13 x 9.25"	255671
BK255674	4	1/4-20 x 9"	255674
BK255675	4	1/4-20 x 9.50"	255675
BK255676	6	1/2-13 x 12.50"	255676
BK255677	6	1/2-13 x 12.75"	255677
BK255678	6	1/2-13 x 13"	255678
BK255679	6	1/2-13 x 13.50"	255679
BK255689	4	1/4-20 x 4"	255689
BK255691	6	1/2-13 x 6"	255691
BK255692	6	1/2-13 x 6.50"	255692
BK255693	6	1/2-13 x 5.25"	255693
BK464125M	4	M5 x 70 mm	464125
BK466834M	4	M5 x 20 mm	466834
BK466836M	4	M5 x 60 mm	466836
BK466837M	4	M5 x 80 mm	466837
BK466838M	4	M5 x 90 mm	466838
BK466839M	4	M5 x 100 mm	466839
BK466840M	4	M5 x 110 mm	466840
BK466841M	4	M5 x 120 mm	466841
BK466842M	4	M5 x 130 mm	466842
BK466843M	4	M5 x 140 mm	466843
BK466844M	4	M5 x 150 mm	466844
BK466845M	4	M5 x 160 mm	466845
BK466846M	4	M5 x 170 mm	466846
BK466847	4	10-24 x .75"	466847
BK466849	4	10-24 x 2.375"	466849
BK466850	4	10-24 x 3.125"	466850
BK466851	4	10-24 x 3.50"	466851
BK466852	4	10-24 x 3.938"	466852

## Bolt Kits

Bolt Kit Number	Bolt Quantity	Thread Size and Length	Assembly Number
BK466853	4	10-24 x 4.312"	466853
BK466854	4	10-24 x 4.75"	466854
BK466855	4	10-24 x 5.125"	466855
BK466856	4	10-24 x 5.50"	466856
BK466857	4	10-24 x 5.937"	466857
BK466858	4	10-24 x 6.312"	466858
BK466859	4	10-24 x 6.688"	466859
BK590724	4	3/8-18 x 1.75" 1/4-20 x 1.75"	590724
BK590730	4	10-24 x 5.375"	590730
BK688701	4	5/16-18 x 1.25"	688701
BK688713	4	5/16-18 x 2.25"	688713
BKCGAM06608	4	5/8-11 x 3.50"	255608
BKCGAM10609	4	3/4-10 x 2.50"	255609
BKCGV06603	6	1/2-13 x 3"	255603
BKCGV815614	4	5/8-11 x 2.25"	255614
BKCG03602	4	1/2-13 x 2"	255602
BKCG06600	4	5/8-11 x 3.25"	255600
BKCG06604	4	5/8-11 x 2.75"	255604
BKCG06605	2 2	5/8-11 x 2.75" 5/8-11 x 3.25"	255605
BKCG10601	4	3/4-10 x 4"	255601
BKCG10606	6	3/4-10 x 2.25"	255606
BKCG10616	4	3/4-10 x 3.50"	255616
BKCG506610	2 4	.6250-11 x 2.250" .6250-11 x 4.750"	255610
BKCG510611	2 4	.7500-10 x 3" .7500-10 x 5"	255611
BKCG805619	4	3/8-16 x 1.75"	255619
BKCG815612	4	5/8-11 x 1.75"	255612
BKCG825613	4	3/4-10 x 2.75"	255613
BKCG825615	4	3/4-10 x 3.50"	255615
BKCPG06607	4	3/8-16 x 4.25"	255607
BKCP06684	4	1/2-13 x 3.75"	255684
BKCP2242680	6	1/2-13 x 3.50"	255680
BKDGAM301651	4	1/4-20 x 1.25"	255651
BKDGAM301652M	4	M6 x 30 mm	255652
BKDGAM521766	2	5/16-18 x 1.50"	255696
BKDGC PFN01673	4	1/4-20 x 8.75"	255673
BKDGC RFN01672	4	1/4-20 x 8.25"	255672
BKDGFNL694	4	10-24 x 2.75"	255694
BKDGFN01624	4	1/4-20 x 4.50"	255624
BKDGFN01637	4	1/4-20 x 3.25"	255637
BKDGFNPC01665	4	1/4-20 x 6.25"	255665

## Bolt Kits

Bolt Kit Number	Bolt Quantity	Thread Size and Length	Assembly Number
BKDGH06618	6	.500-13UNC x3.00"	255618
BKDGH8658M	6	M12 x 80 mm	255658
BKDGN50709M	4	M20 x 80 mm	255657
BKDGPC8656	6	1/2-13 x 7.50"	255656
BKDNG16700	4	5/16-18 x 1.50"	590700
BKDNG16701M	4	M8 x 40 mm	590701
BKDNG50708	4	3/4-10 x 3.00"	590708
BKDPNG25704	4	1/2-13 x 1.50"	590704
BKDPNG40707M	4	M20 x 60 mm	590707
BKDGXFN01666	4	1/4-20 x 5.75"	255666
BKDG3698	4	#10-24 x 2.00"	255698
BKDG3699M	4	M5 x 50 mm	255699
BKDG04650	4 2	3/8-16 x 1.75" 1/4-20 x 1.50"	255650
BKDG06622	4	1/2-13 x 2.50"	255622
BKDG06635	6	1/2-13 x 2.50"	255635
BKDG06689	4	.250-20 x 4.00"	255689
BKDG3699M	4	M5 x 50 mm	255699
BKDG8655M	6	M12 x 65 mm	255655
BKDG10623	6	3/4-10 x 3.00"	255623
BKDG10630	4	3/4-10 x 3.00"	255630
BKDG10636	6	3/4-10 x 2.75"	255636
BKDG1506627	4	3/8-16 x 3.75"	255627
BKDNG63710	4	1.250-7 x 3.50"	590710
BKDNG63711M	4	M30 x 90 mm	590711
BKDPNG25705M	4	M12 x 40 mm	590705
BKFG06649	4	5/8-11 x 3.75"	255649
BKFCGT02644	4	5/16-18 x 3.00"	255644
BKFG03641	4	3/8-16 x 2.50"	255641
BKFG03645	4	3/8-16 x 3.00"	255645
BKFG06642	4	5/8-11 x 4.00"	255642
BKFG06646	4	5/8-11 x 4.00"	255646
BKFG10643	4	3/4-10 x 4.75"	255643
BKFG10647	4	3/4-10 x 4.50"	255647
BKG815612	4	5/8-11 x 1.75"	255612
BKMOD617	4	10-24 x 1.75"	255617
BKPNG16702	4	5/16-18 x 2.00"	590702
BKPNG16703M	4	M8 x 50 mm	590703
BKRX03660	4	3/8-16 x 2.75"	255660
BKRX06661	4	3/8-16 x 3.25"	255661
BKRX10662	6	3/8-16 x 4.00"	255662
BKSA4628	4	5/16-18 x 2.75"	255628

## Bolt Kits

---

<b>Bolt Kit Number</b>	<b>Bolt Quantity</b>	<b>Thread Size and Length</b>	<b>Assembly Number</b>
BKSC4629	4	1/4-20 x 2.25"	255629
BKSD403631	4	5/16-18 x 2.00"	255631
BKSE3638	4	1/4-20 x 1.00"	255638
BKSG02681	2	1/4-20 x 2.00"	255681
BKSF4648	4	1/4-20 x 3.00"	255648
BKSVG903639	4	5/16-18 x 1.75"	255639
BKUR06682	2 4	5/8-11 x 2.50" 5/8-11 x 5.25"	255682
BKUR06683	2 4	3/4-10 x 3.00" 3/4-10 x 6.50"	255683
BKXDG01626	4	1/4-20 x 3.75"	255626
BKXDG01634	4	1/4-20 x 2.50"	255634
BKXLI03663	4	5/16-18 x 3.00"	255663



# SAE 4-bolt Solid Flanges

## General Data

These threaded-connection flanges are for use on standard SAE 4-bolt flange mounting pads and are furnished with seals and screws for mounting. Straight threaded models

are preferred over pipe threaded models because they reduce the possibility of leakage.

FL1-24-24P-LP-10, which is rated at 34,5 bar (500 psi) maximum.

## Operating Pressure

The maximum pressure is 210 bar (3000 psi) for all models except

## Dimensions in Millimeters (Inches)

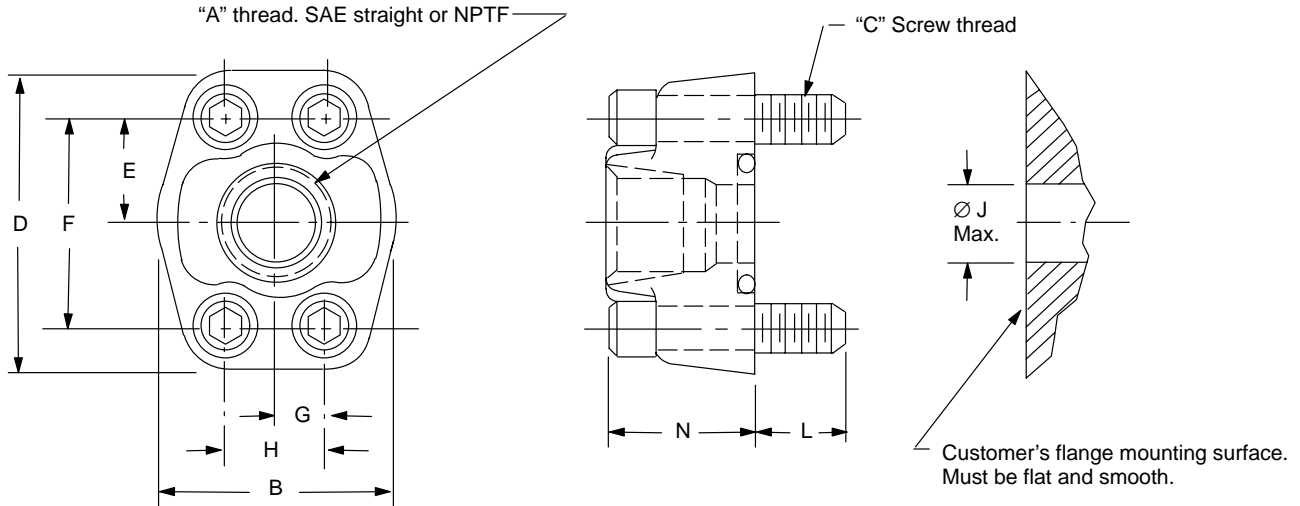

Model Number		A		B	C	D	E	F	G	H	J	L	N
SAE Straight Threaded	NPTF Pipe Threaded	SAE Straight Thread	NPTF Pipe Thd.										
FL1-6-12S-10	-	1.0625-12 (3/4 tube)	-	52,3 (2.06)	3/8-16	65,0 (2.56)	23,9 (0.94)	47,8 (1.88)	11,2 (0.44)	22,4 (0.88)	19,0 (0.75)	13,5 (.53)	31,8 (1.25)
	FL1-6-06P-10	-	3/4										
FL1-8-16S-10	-	1.3125-12 (1" tube)	-	58,7 (2.31)	3/8-16	69,8 (2.75)	26,2 (1.03)	52,4 (2.06)	13,1 (0.52)	26,2 (1.03)	25,4 (1.00)	16,8 (0.66)	35,0 (1.38)
	FL1-8-08P-10	-	1										
FL1-10-20S-10	-	1.625-12 (1-1/4 tube)	-	73,1 (2.88)	7/16-14	79,2 (3.12)	29,4 (1.16)	58,7 (2.31)	15,1 (0.59)	30,2 (1.19)	31,8 (1.25)	21,3 (0.84)	38,1 (1.50)
	FL1-10-10P-10	-	1-1/4										
FL1-12-24S-10	-	1.875-12 (1-1/2 tube)	-	82,6 (3.25)	1/2-13	93,7 (3.69)	35,0 (1.38)	69,8 (2.75)	17,8 (0.70)	35,7 (1.41)	38,1 (1.50)	18,5 (0.73)	41,1 (1.62)
	FL1-12-12P-10	-	1-1/2										
	FL1-16-16P-10	-	2	96,9 (3.81)	1/2-13	101,6 (4.00)	38,9 (1.53)	77,8 (3.06)	21,4 (0.84)	42,9 (1.69)	50,8 (2.00)	18,5 (0.73)	41,1 (1.62)
	FL1-20-20P-10	-	2-1/2	108,7 (4.28)	1/2-13	114,3 (4.50)	44,4 (1.75)	88,9 (3.50)	25,4 (1.00)	50,8 (2.00)	63,5 (2.50)	21,8 (0.86)	50,8 (2.00)
	FL1-24-24P-10	-	3	131,1 (5.16)	5/8-11	134,9 (5.31)	53,2 (2.09)	106,4 (4.19)	31,0 (1.22)	61,9 (2.44)	76,2 (3.00)	24,9 (0.98)	57,2 (2.25)
	FL1-24-24P-LP-10	-	3	131,1 (5.16)	5/8-11	134,9 (5.31)	53,2 (2.09)	106,4 (4.19)	31,0 (1.22)	61,9 (2.44)	76,2 (3.00)	18,5 (0.73)	57,2 (2.25)

# SAE 4-bolt Solid Flanges

## General Data

These pipe-weld flanges are for use on standard SAE 4-bolt flange mounting pads and are furnished with seals and screws for mounting. Pipe-weld models are preferred over pipe threaded models because they reduce the possibility of leakage.

## Operating Pressure

The maximum is 210 bar (3000 psi) for all models except the following, which are rated at 34,5 bar (500 psi) maximum:

FL1-24-24W-LP-10  
 FL1-28-28W-10  
 FL1-32-32W-10

## Dimensions in Millimeters Inches)

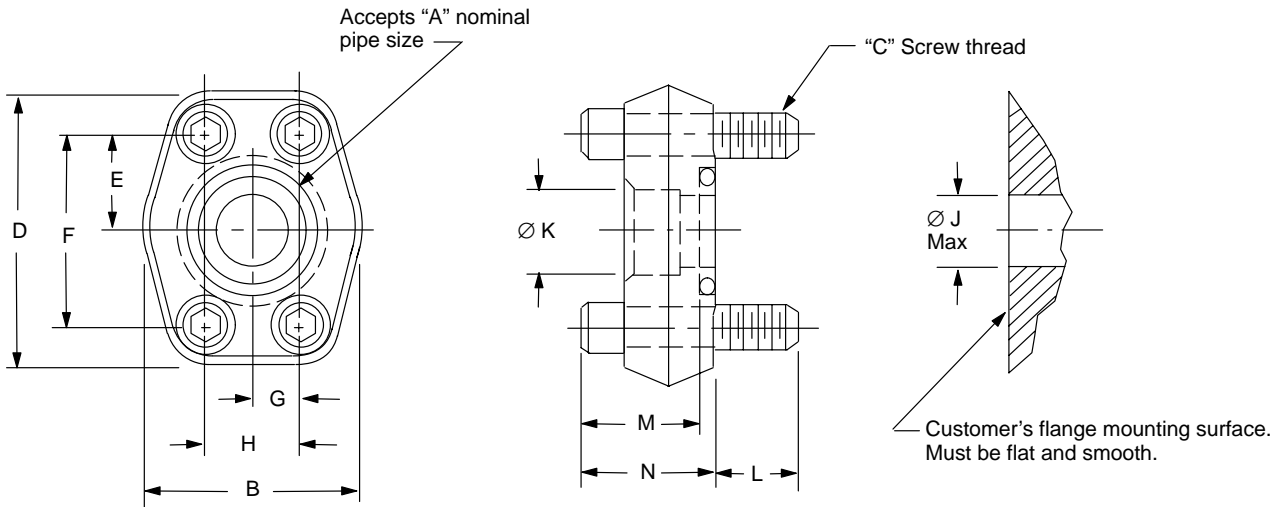

Model Number	A	B	C	D	E	F	G	H	J	K	L	M	N
FL1-8-08W-10	1"	58,7 (2.31)	3/8-16	69,8 (2.75)	26,2 (1.03)	52,4 (2.06)	13,1 (0.52)	26,2 (1.03)	25,4 (1.00)	33,8 (1.33)	19,1 (0.75)	15,7 (.62)	22,4 (.88)
FL1-10-10W-10	1-1/4"	73,1 (2.88)	7/16-14	79,2 (3.12)	29,4 (1.16)	58,7 (2.31)	15,1 (0.59)	30,2 (1.19)	31,8 (1.25)	42,6 (1.68)	23,8 (0.94)	17,5 (0.69)	38,1 (1.50)
FL1-12-12W-10	1-1/2"	82,6 (3.25)	1/2-13	93,7 (3.69)	35,0 (1.38)	69,8 (2.75)	17,8 (0.70)	35,7 (1.41)	38,1 (1.50)	48,9 (1.93)	22,6 (0.89)	19,1 (0.75)	30,2 (1.19)
FL1-16-16W-10	2"	96,9 (3.81)	1/2-13	101,6 (4.00)	38,9 (1.53)	77,8 (3.06)	21,4 (0.84)	42,9 (1.69)	50,8 (2.00)	61,2 (2.41)	24,2 (0.95)	22,2 (0.88)	35,0 (1.38)
FL1-20-20W-10	2-1/2"	108,7 (4.28)	1/2-13	114,3 (4.50)	44,4 (1.75)	88,9 (3.50)	25,4 (1.00)	50,8 (2.00)	63,5 (2.50)	73,9 (2.91)	27,4 (1.08)	25,1 (1.00)	44,4 (1.75)
FL1-24-24W-10	3"	131,1 (5.16)	5/8-11	134,9 (5.31)	53,2 (2.09)	106,4 (4.19)	31,0 (1.22)	61,9 (2.44)	76,2 (3.00)	90,2 (3.55)	24,2 (0.95)	31,8 (1.25)	54,0 (2.12)
FL1-24-24W-LP-10	3"	131,1 (5.16)	5/8-11	134,9 (5.31)	53,2 (2.09)	106,4 (4.19)	31,0 (1.22)	61,9 (2.44)	76,2 (3.00)	90,2 (3.55)	17,8 (0.70)	31,8 (1.25)	54,0 (2.12)
FL1-28-28W-10	3-1/2"	139,7 (5.50)	5/8-11	152,4 (6.00)	60,4 (2.38)	120,6 (4.75)	35,0 (1.38)	69,8 (2.75)	88,9 (3.50)	102,9 (4.05)	28,9 (1.14)	30,2 (1.19)	36,6 (1.44)
FL1-32-32W-10	4"	152,4 (6.00)	5/8-11	162,0 (6.38)	65,0 (2.56)	130,0 (5.12)	38,9 (1.53)	77,7 (3.06)	101,6 (4.00)	116,3 (4.58)	27,4 (1.08)	31,8 (1.25)	38,1 (1.50)

# Pipe-threaded Square Flanges and Unions

## General Data

These straight outlet type flanges are available as a single flange, or as a flange union (single and companion flange combined).

Single flanges come with a seal, and screws and washers for fastening.

Unions include a seal, and "thru" bolts, nuts and washers for fastening. A union's companion flange is similar to its single flange, but has no seal.

## Operating Pressure

The maximum is 210 bar (3000 psi) for all models.

## Dimensions in Millimeters (Inches)

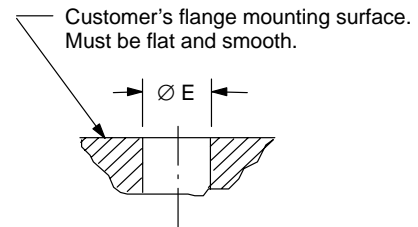
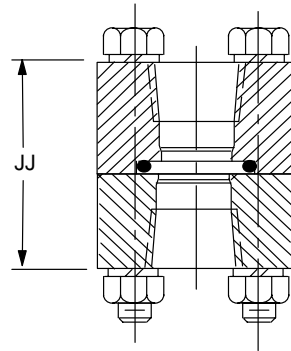
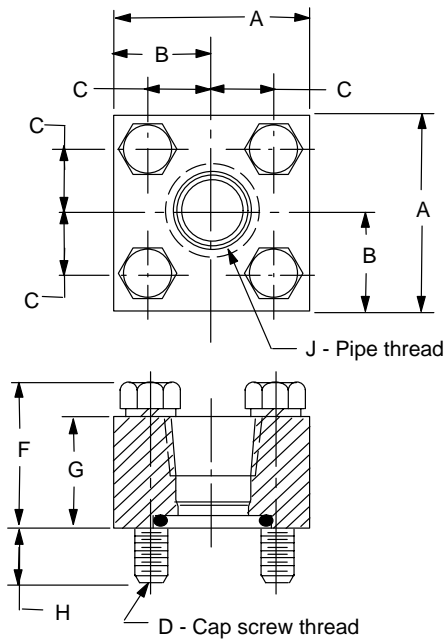

Nominal Pipe Size (Inch)	Single Flange Model Number	Flange Union Model Number	A	B	C	D	E	F	G	H	J	JJ
1-1/2	FL-12-PS-20	-	101,6 (4.00)	50,8 (2.00)	34,93 (1.375)	5/8-11	49,23 (1.938)	60,5 (2.38)	44,5 (1.75)	22,4 (.88)	1-1/2	-
2	FL-16-PS-20	-									2	-
2-1/2	FL-20-PS-20	-									2-1/2	-
3	FL-24-PS-20	FLC-24-PS-20	139,7 (5.50)	69,9 (2.75)	47,63 (1.875)	7/8-9	74,63 (2.938)	79,2 (3.12)	57,2 (2.25)	33,3 (1.31)	3	111,3 (4.38)

# Pipe-threaded Square Flanges and Unions

## General Data

These ell type flanges are available as a single flange, or as a flange union (single and companion flange combined).

Single flanges come with a seal, and screws and washers for fastening.

Unions include a seal, and "thru" bolts, nuts and washers for fastening. A union's companion flange is similar to its single flange, but has no seal.

## Operating Pressure

The maximum is 210 bar (3000 psi) for all models.

## Dimensions in Millimeters (Inches)

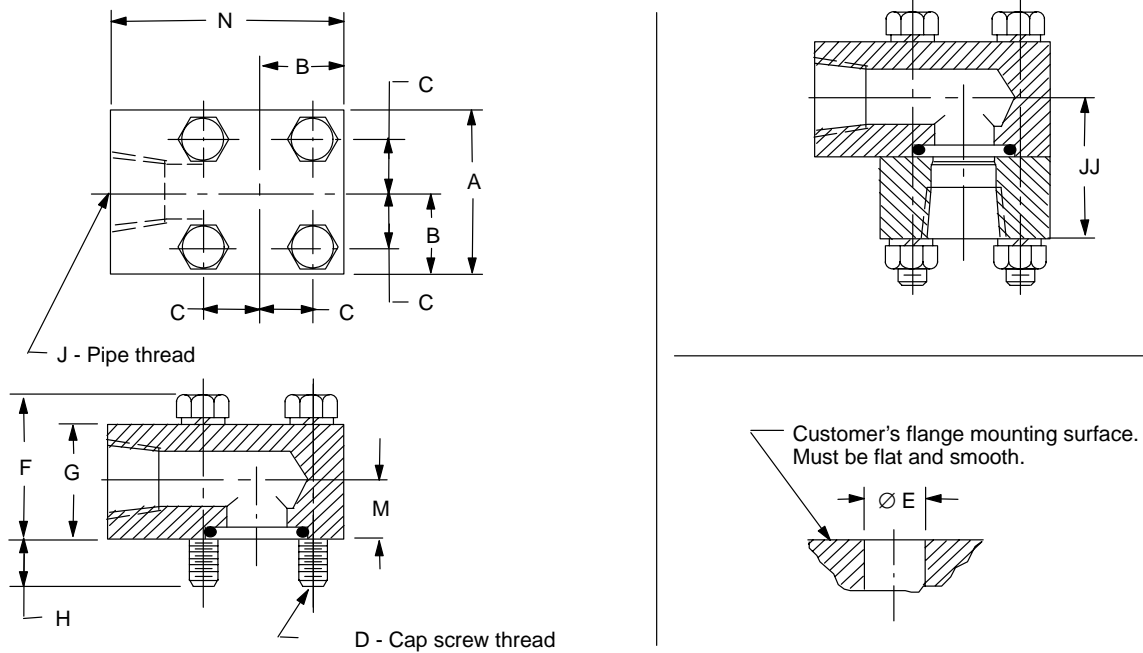

Nominal Pipe Size (Inch)	Single Flange Model Number	Flange Union Model Number	A	B	C	D	E	F	G	H	J	M	N	JJ
1-1/2	FL-12-PL-20	-	101,6 (4.00)	50,8 (2.00)	34,93 (1.375)	5/8-11	49,23 (1.938)	91,9 (3.62)	76,2 (3.00)	22,4 (.88)	1-1/2	38,1 (1.50)	130,0 (5.12)	-
2	FL-16-PL-20	-									2			-
2-1/2	FL-20-PL-20	-	139,7 (5.50)	69,9 (2.75)	47,63 (1.875)	7/8-9	74,63 (2.938)	124,0 (4.88)	101,6 (4.00)	33,3 (1.31)	2-1/2	50,8 (2.00)	180,8 (7.12)	-
3	-	FLC-24-PL-20									3			104,6 (4.12)

# Socket-weld Square Flanges and Unions

## General Data

These straight outlet type flanges are available as a single flange, or as a flange union (single and companion flange combined). Their pipe-weld connection is preferred over pipe threads because of a reduced tendency to leak.

Single flanges come with a seal, and screws and washers for fastening. Unions include a seal, and “thru” bolts, nuts and washers for fastening. A union’s companion flange is similar to its single flange, but has no seal.

are rated at 345 bar (5000 psi) maximum:

FL-16-WS-HP-10  
FL-20-WS-HP-20  
FL-24-WS-HP-20

## Operating Pressure

The maximum is 210 bar (3000 psi) for all models except the following, which

## Dimensions in Millimeters (Inches)

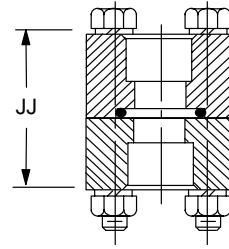
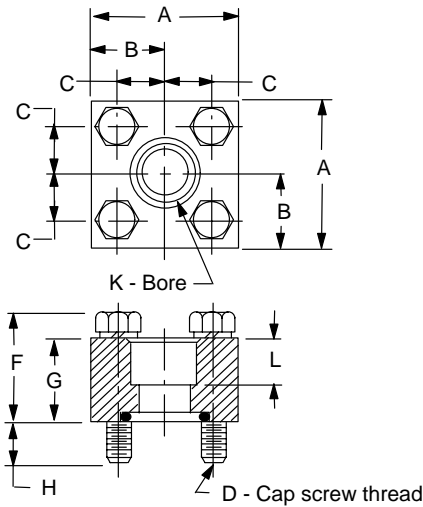

Customer's flange mounting surface.  
Must be flat and smooth.

Nominal Pipe Size (Inch)	Single Flange Model Number	Flange Union Model Number	A	B	C	D	E	F
1-1/4	FL-10-WS-20	FLC-10-WS-20	76,2 (3.00)	38,1 (1.50)	25,40 (1.000)	1/2-13	31,75 (1.250)	48,5 (1.91)
1-1/2	FL-12-WS-20	FLC-12-WS-20	101,6 (4.00)	50,8 (2.00)	34,93 (1.375)	5/8-11	42,88 (1.688)	57,7 (2.27)
2	FL-16-WS-20 FL-16-WS-HP-20 *	FLC-16-WS-20					49,23 (1.938)	
2-1/2	FL-20-WS-20 FL-20-WS-HP-20 *	—	139,7 (5.50)	69,9 (2.75)	47,63 (1.875)	7/8-9	66,68 (2.625)	75,7 (2.98)
3	FL-24-WS-20 FL-24-WS-HP-20 *	FLC-24-WS-20					74,63 (2.938)	

Nominal Pipe Size (Inch)	Single Flange Model Number	Flange Union Model Number	G	H	K	L	JJ
1-1/4	FL-10-WS-20	FLC-10-WS-20	38,1 (1.50)	16,8 (.66)	42,57/42,70 (1.676/1.681)	30,0 (1.18)	73,2 (2.88)
1-1/2	FL-12-WS-20	FLC-12-WS-20	44,5 (1.75)	22,4 (.88)	48,67/48,79 (1.916/1.921)	33,3 (1.31)	82,6 (3.25)
2	FL-16-WS-20 FL-16-WS-HP-20 *	FLC-16-WS-20			61,14/61,26 (2.407/2.412)		
2-1/2	FL-20-WS-20 FL-20-WS-HP-20 *	—	57,2 (2.25)	33,3 (1.31)	73,84/73,96 (2.907/2.912)	44,5 (1.75)	—
3	FL-24-WS-20 FL-24-WS-HP-20 *	FLC-24-WS-20			89,81/89,94 (3.536/3.541)		

\* See “Operating Pressure” at top of page.

# Socket-weld Square Flanges and Unions

## General Data

These ell type flanges are available as a single flange, or as a flange union (single and companion flange combined). Their pipe-weld connection is preferred over pipe threads because of a reduced tendency to leak.

Single flanges come with a seal, and screws and washers for fastening.

Unions include a seal, and "thru" bolts, nuts and washers for fastening. A union's companion flange is similar to its single flange, but has no seal.

## Operating Pressure

The maximum is 210 bar (3000 psi) for all models.

## Dimensions in Millimeters (Inches)

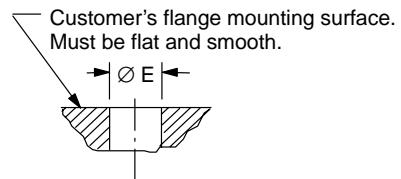
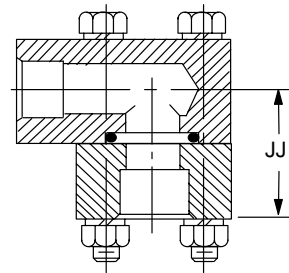
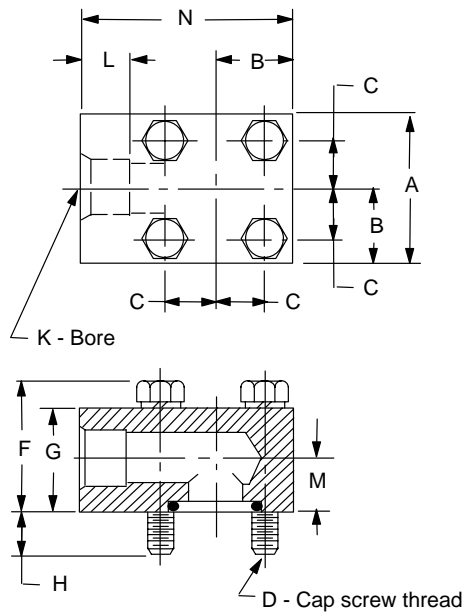

Nominal Pipe Size (Inch)	Single Flange Model Number	Flange Union Model Number	A	B	C	D	E	F	G
1-1/4	FL-10-WL-30	FLC-10-WL-30	76,2 (3.00)	38,1 (1.50)	25,40 (1.000)	1/2-13	31,75 (1.250)	67,1 (2.64)	57,2 (2.25)
1-1/2	FL-12-WL-20	FLC-12-WL-20	101,6 (4.00)	50,8 (2.00)	34,93 (1.375)	5/8-11	49,23 (1.938)	89,4 (3.52)	76,2 (3.00)
2	FL-16-WL-20	FLC-16-WL-20							
2-1/2	–	FLC-20-WL-20	139,7 (5.50)	69,9 (2.75)	47,63 (1.875)	7/8-9	74,63 (2.938)	120,1 (4.73)	101,6 (4.00)
3	FL-24-WL-30	FLC-24-WS-30						132,8 (5.23)	114,3 (4.50)

Nominal Pipe Size (Inch)	Single Flange Model Number	Flange Union Model Number	H	K	L	M	N	JJ
1-1/4	FL-10-WL-30	FLC-10-WL-30	16,8 (.66)	42,57/42,70 (1.676/1.681)	30,0 (1.18)	28,4 (1.12)	104,6 (4.12)	63,5 (2.50)
1-1/2	FL-12-WL-20	FLC-12-WL-20	22,4 (.88)	48,67/48,79 (1.916/1.921)	33,3 (1.31)	38,1 (1.50)	130,0 (5.12)	76,2 (3.00)
2	FL-16-WL-20	FLC-16-WL-20		61,14/61,26 (2.407/2.412)				
2-1/2	–	FLC-20-WL-20	33,3 (1.31)	73,84/73,96 (2.907/2.912)	44,5 (1.75)	50,8 (2.00)	180,8 (7.12)	104,6 (4.12)
3	FL-24-WL-30	FLC-24-WS-30		89,81/89,94 (3.536/3.541)				49,0 (1.93)

# Foot Bracket Kits

The foot bracket kits tabulated below can be used to mount pumps or motors having standard SAE-J 744 2-bolt A, B, or C mounting flanges. These designations correspond to -A-, -B-, and -C- letters in the foot bracket kit model numbers.

The pump or motor mounts to the bracket by using either pair of diametrically opposed holes on the bracket's bolt circle, and the screws furnished.

Also available are a bracket (part number 279625) and mounting screws (part number 214794, 2 required) to fit SAE D mounting flanges.

## Dimensions in Millimeters (Inches)

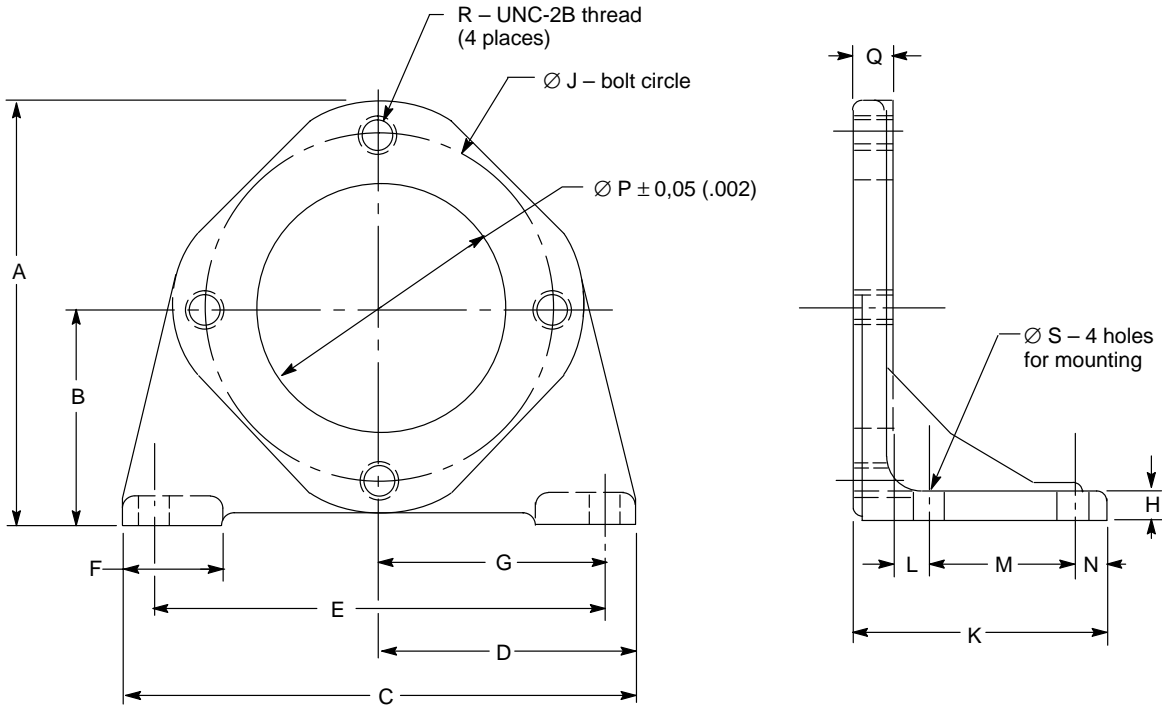

Model No.	A	B	C	D	E	F	G	H
FB-A-10	134,9 (5.31)	69,9 (2.75)	152,4 (6.00)	76,2 (3.00)	127 (5.00)	36,6 (1.44)	63,5 (2.50)	12,7 (.50)
FB-B-10	180,8 (7.12)	92,2 (3.63)	171,5 (6.75)	85,8 (3.38)	146 (5.75)	36,6 (1.44)	73,2 (2.88)	12,7 (.50)
FB-C-10	215,9 (8.50)	109,5 (4.31)	265,2 (10.44)	132,6 (5.22)	235 (9.25)	50,8 (2.00)	117,6 (4.63)	15,7 (.62)

Model No.	J	K	L	M	N	P	Q	R	S
FB-A-10	106,4 (4.19)	96 (3.78)	15 (.59)	50,8 (2.00)	12,7 (.50)	82,63 (3.253)	17,5 (.69)	.38-16	11,2 (.44)
FB-B-10	146 (5.75)	95,8 (3.77)	15 (.59)	50,8 (2.00)	12,7 (.50)	101,68 (4.003)	17,3 (.68)	.50-13	17,3 (.68)
FB-C-10	181,1 (7.13)	131,6 (5.18)	19 (.75)	76,2 (3.00)	17,3 (.68)	127,08 (5.003)	19 (.75)	.62-11	17,3 (.68)

# Needle Valves – 5000 psig, 1/4-3/4 NPTF Connections

## General Data

These valves may be used for restricting fluid flow where uniform flow rates are not essential. The body of the valves is made of carbon steel, the stem of stainless steel, and the handle of aluminum. The packing is Teflon\*, so the valves are suitable for use with all commonly used fluids. Nuts for panel mounting of the valves are furnished, except as noted, and shipped as loose items.

\* Registered trademark of DuPont Co.

mounting of the valves are furnished, except as noted, and shipped as loose items.

## Ratings

Maximum operating pressure is 345 bar (5000 psig). Minimum burst pressure is 1379 bar (20,000 psig). The operating temperature range is -40 to 149° C (-40 to 300° F).

## Standard Graphical Symbol for Fluid Power Diagrams

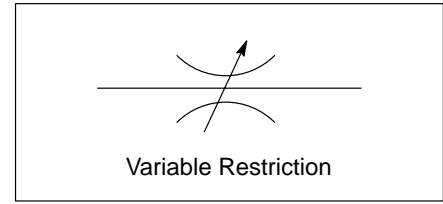

## Dimensions in Millimeters (Inches)

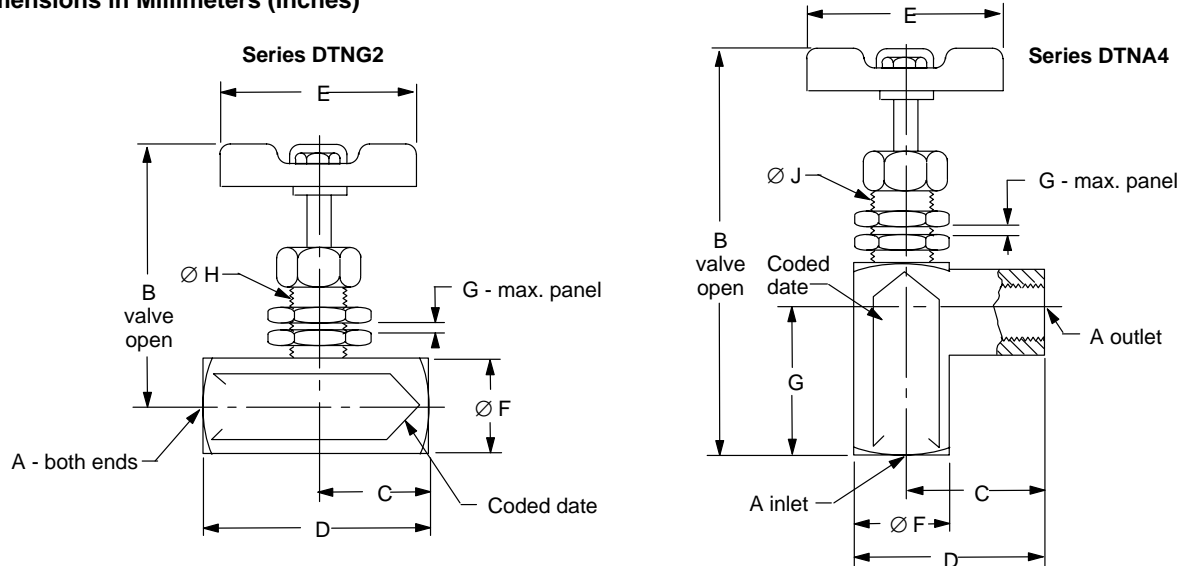

## Series DTNA4 Dimensions

Model Number	A	B	C	D	E	F	G	H	J	Orifice
DTNA4-02-PM-10	1/4	115,8 (4.56)	32,5 (1,28)	46,0 (1.81)	63,5 (2.50)	25,4 (1.00)	26,9 (1.06)	9,7 (.38)	15,7 (.62)	5,6 (.22)
DTNA4-03-PM-10	3/8	136,7 (5.38)	38,9 (1.53)	54,9 (2.16)		31,8 (1.25)	44,5 (1.75)		19,1 (.75)	
DTNA4-04-PM-10	1/2									
DTNA4-06-PM-10 †	3/4	180,8 (7.12)	46,7 (1.84)	69,9 (2.75)	108,0 (4.25)	44,5 (1.75)	49,3 (1.94)	22,4 (.88)	38,1 (1.50)	19,1 (.75)

## Series DTNG2 Dimensions

Model Number	A	B	C	D	E	F	G	H	Orifice
DTNG2-02-PM-10	1/4	88,9 (3.50)	26,2 (1.03)	52,3 (2.06)	63,5 (2.50)	22,4 (.88)	9,7 (.38)	15,7 (.62)	5,6 (.22)
DTNG2-03-PM-10	3/8	91,9 (3.62)	35,1 (1.38)	69,9 (2.75)		28,4 (1.12)		19,1 (.75)	
DTNG2-04-PM-10	1/2								
DTNG2-06-PM-10 †	3/4	131,8 (5.19)	46,0 (1.81)	91,9 (3.62)	108,0 (4.25)	38,1 (1.50)	22,4 (.88)	38,1 (1.50)	19,1 (.75)

† Panel mount nuts not included with this model. To panel mount, order two nuts, part number 591723.



# Needle Valves – 3000 psig, 1/4 NPTF Connections

## General Data

These valves may be used in hydraulic circuits as a shut-off valve in pressure gage lines or other small capacity lines. The body and handle of the valves are made of brass, and the stem of stainless steel. The packing is Teflon\*, so the valves are suitable for use with all commonly used fluids.

\* Registered trademark of DuPont Co.

## Ratings

Maximum operating pressure is 210 bar (3000 psig). Minimum burst pressure is 552 bar (8000 psig). The operating temperature range is -40 to 149° C (-40 to 300° F). Flow rates are shown in the following chart.

Approximate Flow at Maximum Open  
(Based on Light Oil)

Pressure Drop bar (psi)	Flow - L/min (USgpm)
0,34 (5)	4,16 (1.1)
0,69 (10)	5,68 (1.5)
1,38 (20)	8,33 (2.2)
2,76 (40)	11,73 (3.1)
4,14 (60)	14,01 (3.7)
5,52 (80)	16,28 (4.3)

## Standard Graphical Symbol for Fluid Power Diagrams

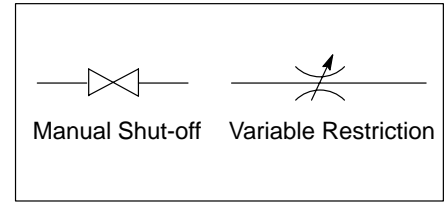

## Dimensions in Millimeters (Inches)

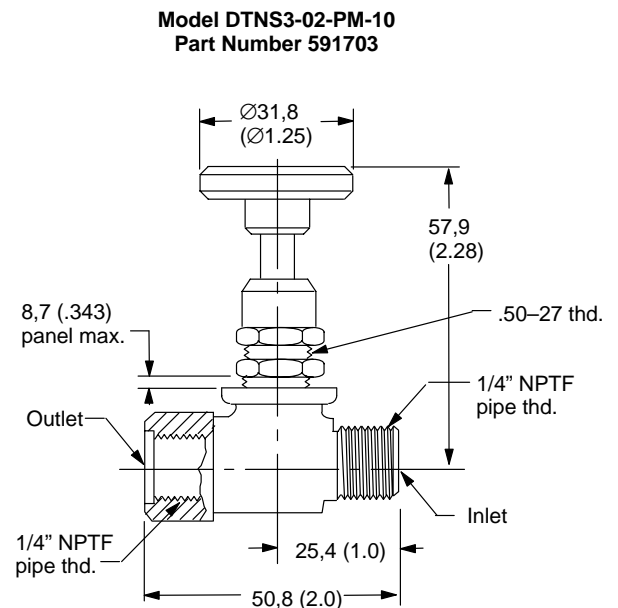
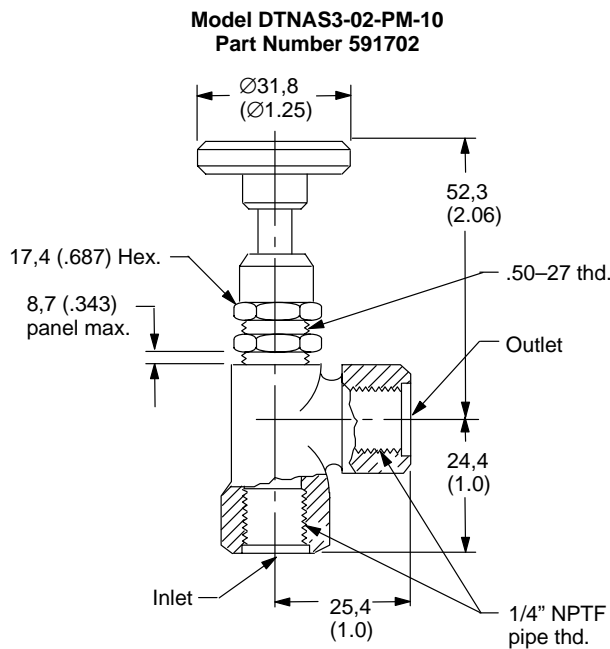

# Angle and Globe Valves, Needle and Plug Types

## General Data

Plug-type valves are used mainly to open or close a portion of a hydraulic control circuit. They are recommended where restricted fluid flow (pressure drop) should be minimized.

Needle-type valves are used for restricting fluid flow (for example, to pilot control circuits), or for any other

purpose where uniform flow rates are not essential.

Plug-type valves are made of carbon steel, including the stem. Needle valves are made of forged carbon steel and have a stainless steel stem. All valves are suitable for use with all commonly used hydraulic fluids.

## Pressure

Maximum operating pressure is 210 bar(3000 psig).

## Standard Graphical Symbol for Fluid Power Diagrams

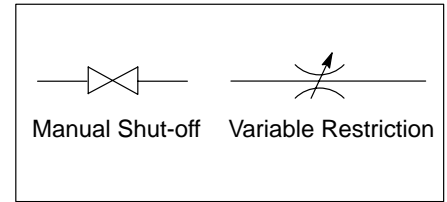

## Dimensions in Millimeters (Inches)

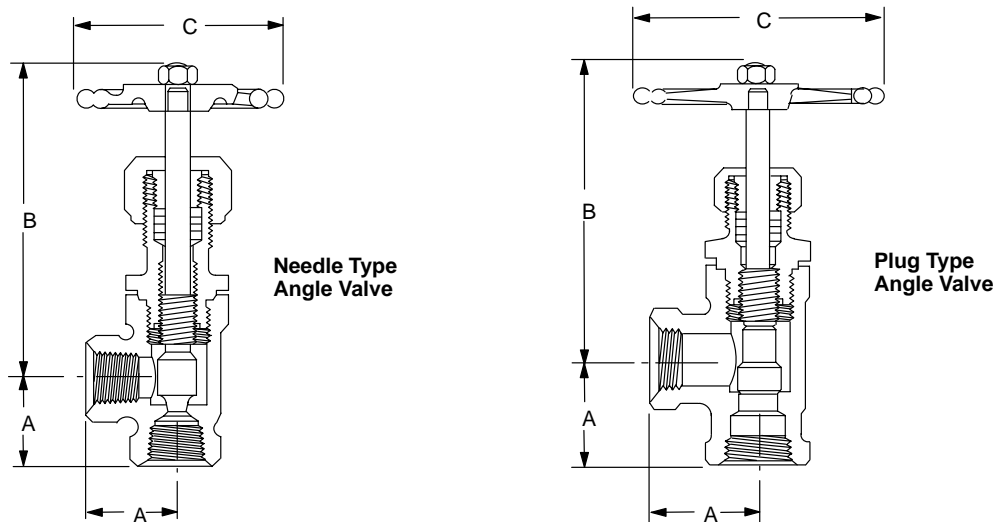

For Piping Size (in)	Port Opening Diameter	Plug Valve Model Number	Needle Valve Model Number	A	B (Open)	C	Weight kg (lb)
1/4	7,93 (.312)	DTPA2-02-10	-	39,6 (1.56)	149,4 (5.88)	82,6 (3.25)	1,47 (3.25)
3/8		DTPA2-03-10	-				
1/2	9,53 (.375)	DTPA2-04-10	-	47,8 (1.88)	162,1 (6.38)	101,6 (4.00)	2,38 (5.25)
3/4	14,29 (.562)	DTPA2-06-10	-	55,6 (2.19)	184,2 (7.25)	120,7 (4.75)	3,74 (8.25)
1	15,88 (.625)	-	DTNA2-08-10	50,8 (2.00)	193,8 (7.63)		3,18 (7.00)
	19,05 (.750)	DTPA2-08-10	-	63,5 (2.50)	209,6 (8.25)	146,1 (5.75)	5,44 (12.00)
1-1/4	25,40 (1.000)	DTPA2-10-10	-	76,2 (3.00)	231,9 (9.13)	177,8 (7.00)	8,16 (18.00)
1-1/2	31,75 (1.250)	DTPA2-12-10	-	85,9 (3.38)	260,4 (10.25)	203,2 (8.00)	12,93 (28.50)

# Angle and Globe Valves, Needle and Plug Types

Dimensions in Millimeters (Inches)

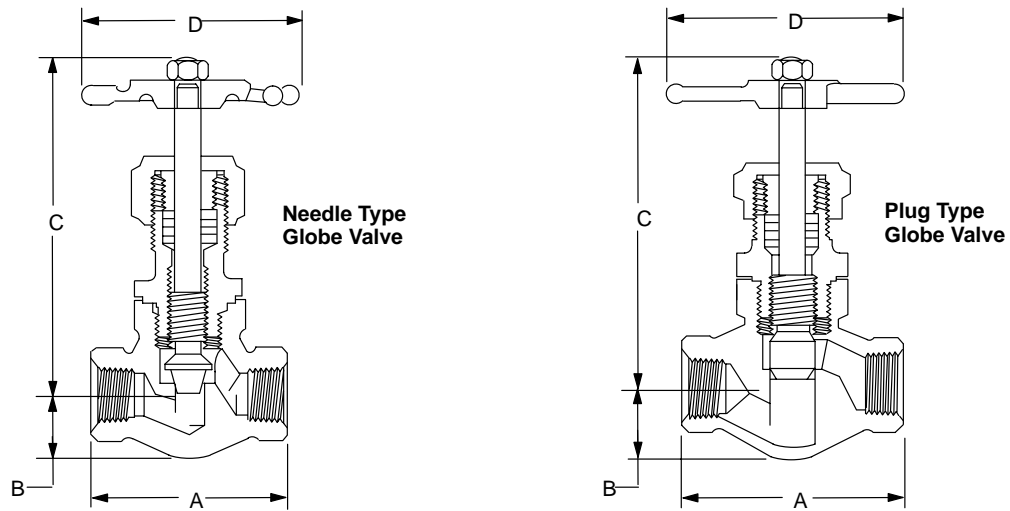

For Piping Size (in)	Port Opening Diameter	Plug Valve Model Number	Needle Valve Model Number	A	B	C (Open)	D	Weight kg (lb)
1/4	7,93	DTPG2-02-10	–	79,5	23,9	149,4	82,6	1,70
3/8	(.312)	DTPG2-03-10	–	(3.13)	(.94)	(5.88)	(3.25)	(3.75)
1/2	9,53	DTPG2-04-10	–	92,2	28,7	171,5	101,6	2,61
	(.375)			(3.63)	(1.13)	(6.75)	(4.00)	(5.75)
3/4	14,29	DTPG2-06-10	–	111,3 (4.38)	37,3	190,5	120,7	4,20
	(.562)				(1.47)	(7.50)	(4.75)	(9.25)
1	15,88	–	DTNG2-08-10	101,6	38,1	193,8		3,40
	(.625)			(4.00)	(1.50)	(7.63)		(7.50)
	19,05	DTPG2-08-10	–	127,0	44,5	214,4	146,1	6,24
	(.750)			(5.00)	(1.75)	(8.44)	(5.75)	(13.75)
1-1/4	25,40	DTPG2-10-10	–	152,4	55,6	230,1	177,8	9,30
	(1.000)			(6.00)	(2.19)	(9.06)	(7.00)	(20.50)
1-1/2	31,75	DTPG2-12-10	–	171,5	68,3	273,1	203,2	14,74
	(1.250)			(6.75)	(2.69)	(10.75)	(8.00)	(32.50)
2	38,10	DTPG2-16-10	–	209,6	79,5	282,7	247,7	20,64
	(1.500)			(8.25)	(3.13)	(11.13)	(9.75)	(45.50)

# Air-type Oil Coolers

## General Data

Air-type coolers provide ample oil cooling where water is too costly or not readily available. They also increase ambient air temperature by circulating waste heat absorbed in the cooling process.

The coolers have an efficient heat transfer element or core made of steel tubes, aluminum fins, and tubular steel manifolds. An electric motor-driven fan forces air across the cooling element.

Coolers are designed for one- or two-pass installations. The two-pass arrangement is especially adaptable where very low flows are encountered. See selection procedure below.

## Ratings

Maximum operating pressure is 20,7 bar (300 psi). The temperature of entering fluid must not exceed 204° C (400° F). For effective oil cooling, ambient air temperature should not exceed 40° C (104° F).

 [Click here for flow data shown in curves for one-pass installations.](#)

 [Click here for two-pass flow data.](#)

## Cooler Selection Procedure

**Example 1:** Oil flow rate is 189 L/min (50 USgpm) and cooler must remove 381 Btu/min (9 hp). Ambient air temperature is 24° C (75° F). Oil temperature is 52° C (125° F).

*Step No. 1:* For 189 L/min (50 USgpm), a single-pass installation is indicated. From performance curves, note that at the temperature difference – 52° C (125° F) minus 24° C (75° F) – in the single-pass mode, the OCA-130-30 will remove about 350 Btu.

 [Click here for curves.](#)

*Step No. 2:* Since the performance of the single-pass OCA-130-30 is based on 57 L/min (15 USgpm), apply a heat transfer correction factor for 189 L/min (50 USgpm) from the heat transfer graph.

 [Click here for graph.](#)

The correction factor is 1.37, and  $1.37 \times 350 \text{ Btu} = 480 \text{ Btu}$ . This shows that in this application OCA-130-30 will remove 480 Btu/min, a good safety factor for the 381 Btu/min required.

*Step No. 3:* From pressure drop curves, and based on the viscosity range of the oil being cooled, establish the pressure drop through the cooler at 52° C (125° F).

 [Click here for curves.](#)

The protecting check valve around the cooler should bypass at a pressure at least 25% above the 52° C (125° F) pressure drop to assure full flow through the cooler at normal system flow. At higher viscosities during system warm-up, the system back pressure may be up to the check valve bypass pressure. Heat transfer is not much affected by viscosity, but pressure drop is affected.

 [Click here for curves.](#)

Determine that this pressure is acceptable in the circuit.

**Example 2:** Oil flow rate is 38 L/min (10 USgpm) and cooler must remove 381 Btu/min (9 hp). Ambient air temperature is 24° C (75° F). Oil temperature is 52° C (125° F).

*Step No. 1:* For 38 L/min (10 USgpm), a two-pass installation is indicated. From performance curves, note that at the temperature difference – 52° C (125° F) minus 24° C (75° F) – in the single pass mode, the OCA-174-30 will remove about 400 Btu.

 [Click here for curves.](#)

*Step No. 2:* Since the performance of the two-pass OCA-174-30 is based on 34 L/min (9 USgpm), apply a heat transfer correction factor for 38 L/min (10 USgpm) from the heat transfer graph.

 [Click here for graph.](#)

The correction factor is 1.05, and  $1.05 \times 400 \text{ Btu} = 420 \text{ Btu}$ . This shows that in this application the OCA-174-30 will remove 420 Btu/min, an acceptable safety factor for the 381 Btu/min required.

*Step No. 3:* Follow the procedure in Example 1, but use different pressure drop curves.

 [Click here for curves.](#)

## Electric Motor Data

Cooler Model	hp	r/min	Voltage	Cycle	Phase	Design
OCA-24-30	1/15	1550	115	60	Single	Single speed, AC, shaded pole, sleeve bearing, totally enclosed, non-ventilated.
OCA-55-30	1/12					Single speed, AC, permanent split capacitor, sleeve bearing, totally enclosed, non-ventilated.
OCA-130-30	1/6	1075	230/460	Three		Single speed, AC, permanent split capacitor, ball bearing, totally enclosed, non-ventilated.
OCA-174-30					Squirrel cage, ball bearing, totally enclosed, non-ventilated.	
OCA-360-30	1/2					

# Air-type Oil Coolers

## Motor Connections

Connect motor to power supply for voltage and frequency (cycles) on motor nameplate only, and according to diagram furnished with motor. Connect two-speed switch, when furnished, according to diagram included with two-speed switch. Before turning on electric power, rotate fan by hand, making sure it has proper clearance and has not been damaged.

If motor is to be protected against overcurrent through a motor starter or other overcurrent device, select overcurrent relays or heaters based on actual measured current draw of motor on completed installation. (Do not use nameplate amperes.) Motor load on this cooler is based on actual temperature test of motor.

## Motor Lubrication

Lubricate according to instructions furnished with motor.

## Fluids

Performance is based on the use of petroleum oil. Contact your Vickers representative when other fluids are to be cooled.

## Filtration

A strainer or filter should be installed ahead of the cooler (if not located elsewhere in the system) to trap scale, dirt, or sludge that may be present in the circuit, or accumulates from oil breakdown.

## Pressure Surges

A spring-loaded check valve installed in parallel with the cooler is recommended to provide overload protection against excessive pressure surges.

## Environment

Avoid locating the cooler in a corrosive atmosphere. Rapid deterioration of the casing, cooling element, fan and motor may occur, resulting in shortened life.

## Cleaning

Dirt on cooling element fins reduces air flow and cooling capacity. Do not bend or damage cooling element fins. Dirt on fan blades reduces air output and may throw fan out of balance and overload motor. Dirt on the motor reduces ventilation and cooling, causing overheating and possible burnout. Clean as required to provide optimum cooling efficiency.

Once a year, disconnect piping and circulate a degreasing agent or flushing oil through the cooler to remove sludge from internal tube surfaces to return the unit to full capacity.

## Temperature Control & Bulb Well

The temperature control (model OCTC-1-21) has a bulb that installs in the system reservoir, senses oil temperature, and causes the cooler's fan motor to turn on or off. The temperature setting is adjusted with an external knob and calibrated scale. A switch differential of  $-16$  to  $-12^{\circ}\text{C}$  ( $3$  to  $10^{\circ}\text{F}$ ) is adjustable with a wheel located under the control's cover.

The temperature range of the control is  $13$  to  $79^{\circ}\text{C}$  ( $55$  to  $175^{\circ}\text{F}$ ). Maximum safe bulb temperature is  $93^{\circ}\text{C}$  ( $200^{\circ}\text{F}$ ). Maximum bulb pressure is 3,4 bar (50 psi). The electrical rating is 8 amp @ 120 Vac; 5.1 amp @ 240 Vac.

The stainless steel bulb well (model OCBW-2-20) should be used when it's necessary to protect the element of the temperature control's bulb from mechanical or chemical damage, or to permit removal of the bulb without draining the reservoir.

The temperature control and bulb well are not included with the cooler and must be ordered separately.

## Standard Graphical Symbols for Fluid Power Diagrams

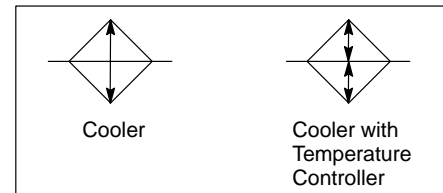

# Air-type Oil Coolers

## Sizing and Performance Curves for One-pass Installations

Based on 32 cSt (150 SUS) oil

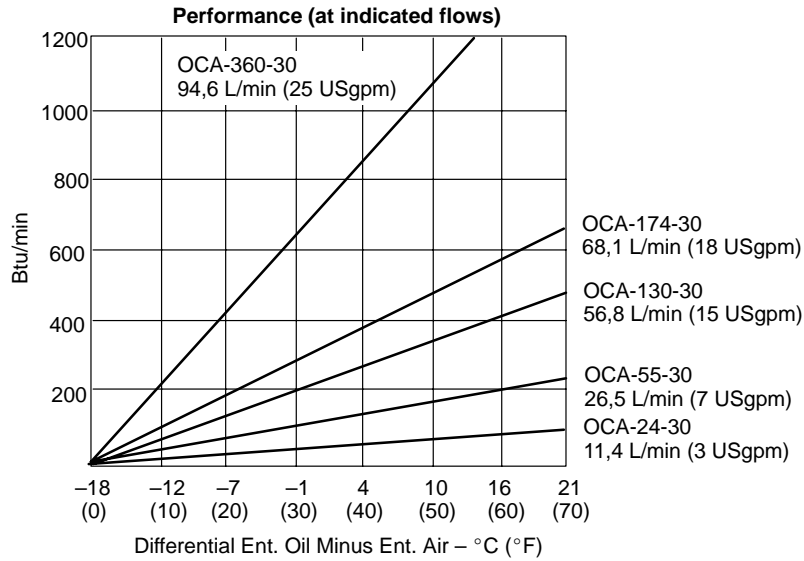

**Note:** Refer to "Heat Transfer & Pressure Drop Correction Factors for Oil Viscosity Changes" curves on following page.

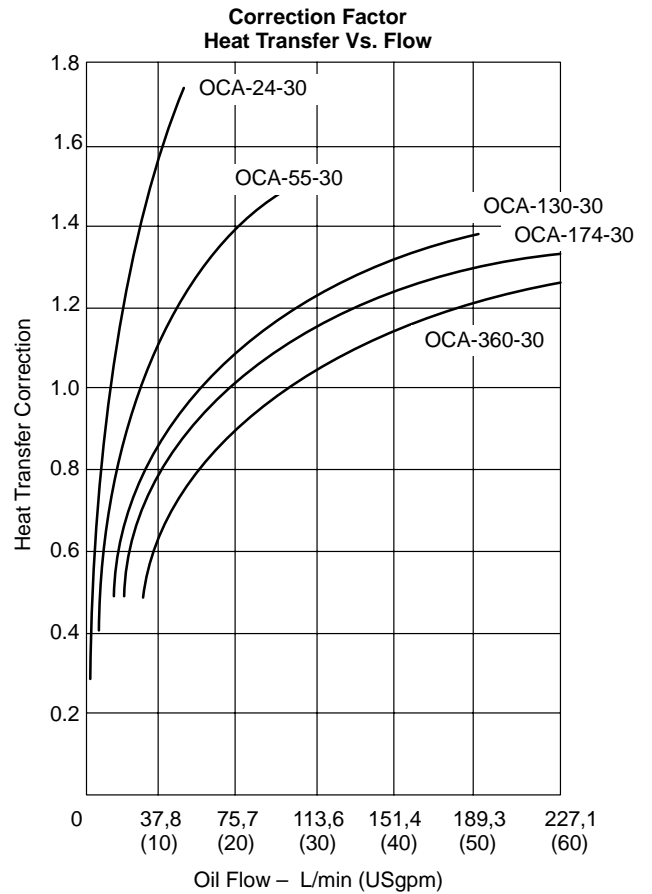
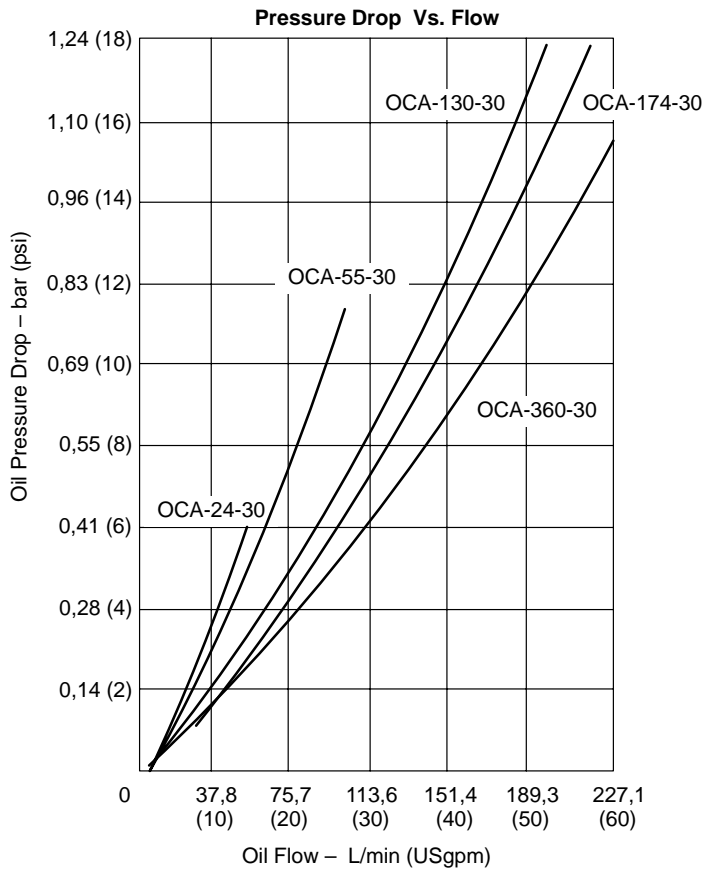

# Air-type Oil Coolers

## Sizing and Performance Curves for Two-pass Installations

Based on 32 cSt (150 SUS) oil

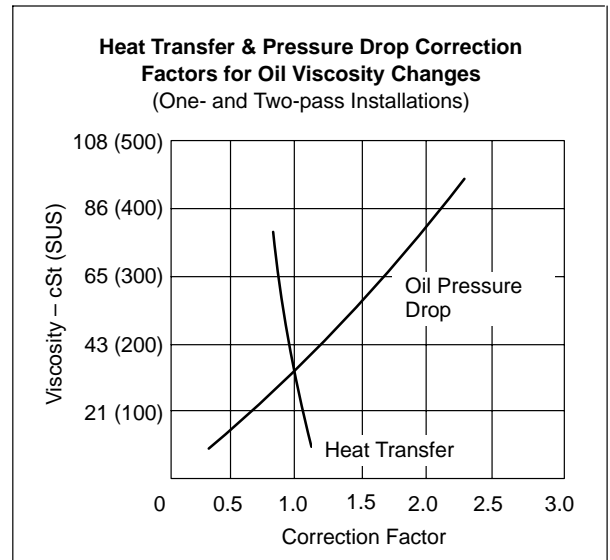
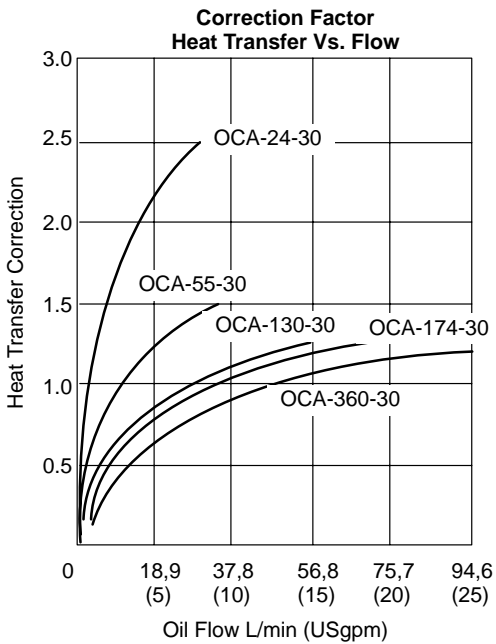
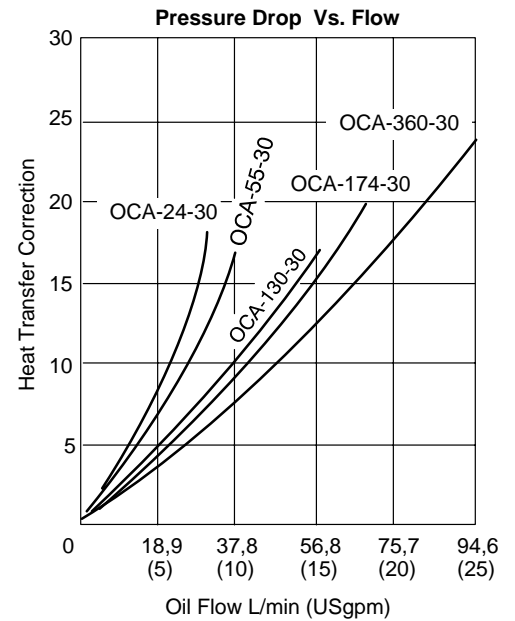
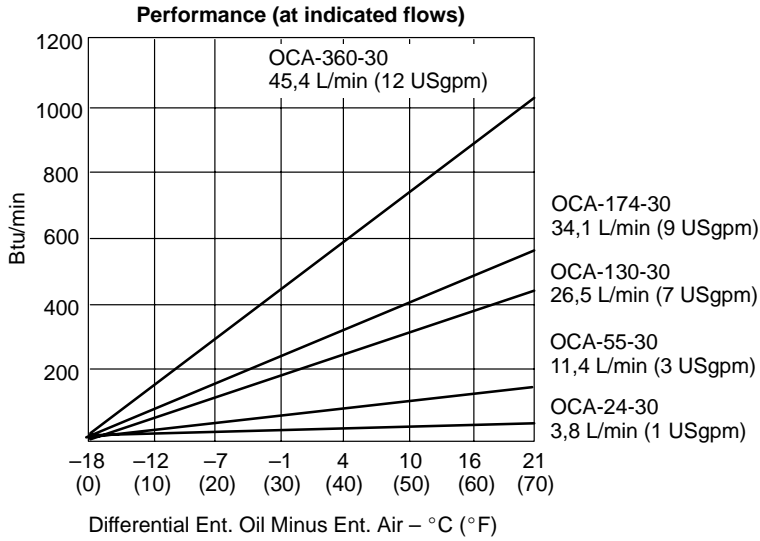

# Air-type Oil Coolers

## Piping Diagrams

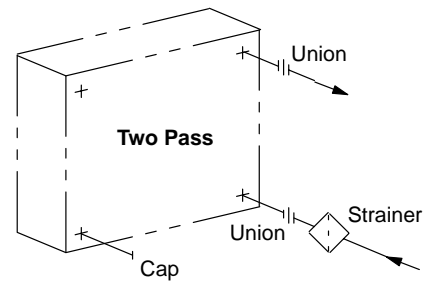
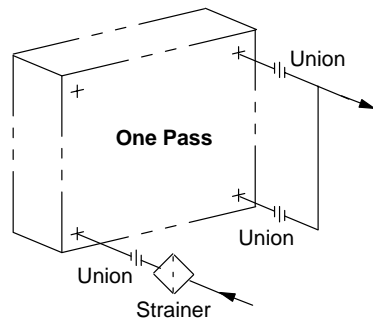

## Dimensions in Millimeters (Inches)

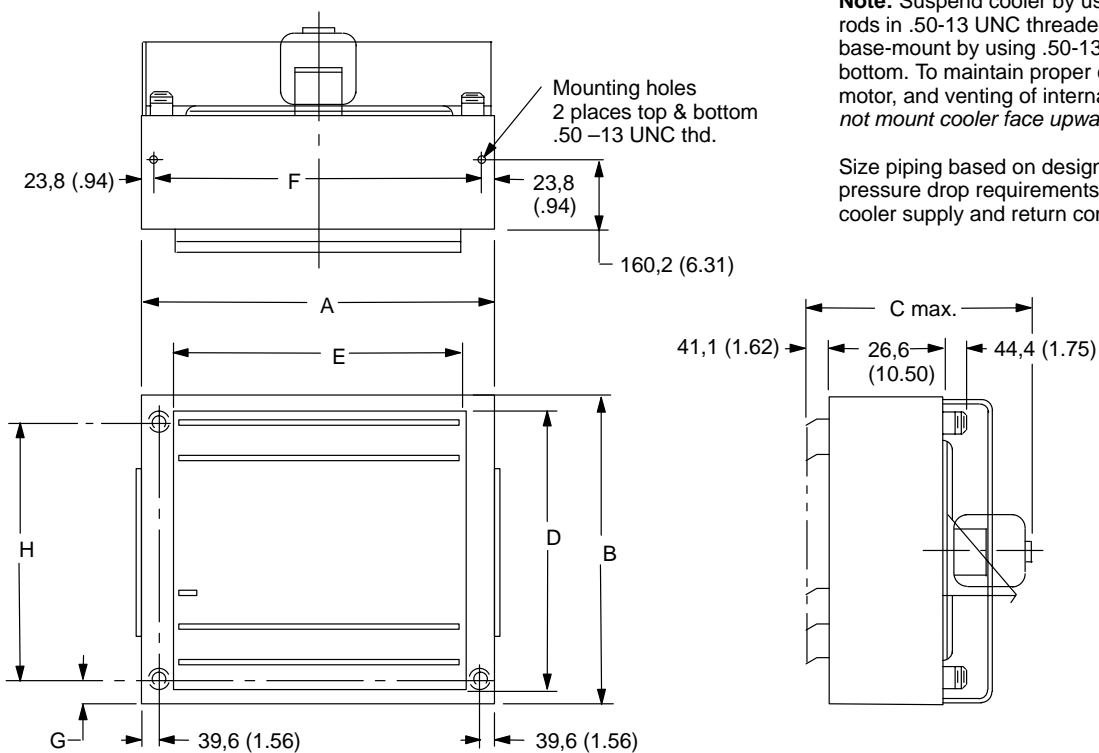

Model Number	A	B	C	D	E	F	G	H	K	Approx. Weight kg (lb)
OCA-24-30	376,2 (14.81)	300 (11.81)	354,1 (13.94)	233,4 (9.19)	211,1 (8.31)	328,7 (12.94)		249,2 (9.81)	25,4 (1)	24,95 (55)
OCA-55-30	517,7 (20.38)	400,1 (15.75)		333,2 (13.12)	352,6 (13.88)	469,9 (18.5)	53,8 (2.12)	345,9 (13.62)		34,02 (75)
OCA-130-30	681 (26.81)	599,9 (23.62)	558,8 (22)	533,4 (21)	512,8 (20.19)	630,2 (24.81)		544,6 (21.44)		54,43 (120)
OCA-174-30	803,1 (31.62)	700 (27.56)		633,5 (24.94)	638 (25.12)	755,7 (29.75)	55,6 (2.19)	644,7 (25.38)	31,8 (1.25)	68,04 (150)
OCA-360-30	1057,1 (41.62)	933,5 (36.75)	596,9 (23.5)	866,6 (34.12)	892 (35.12)	1009,7 (39.75)		877,8 (34.56)		108,86 (240)



# Air-type Oil Coolers

Dimensions in Millimeters (Inches)

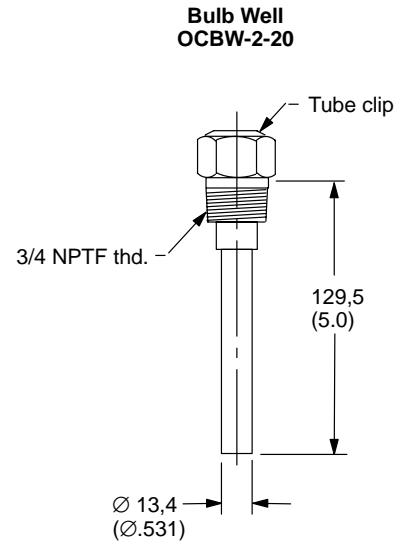
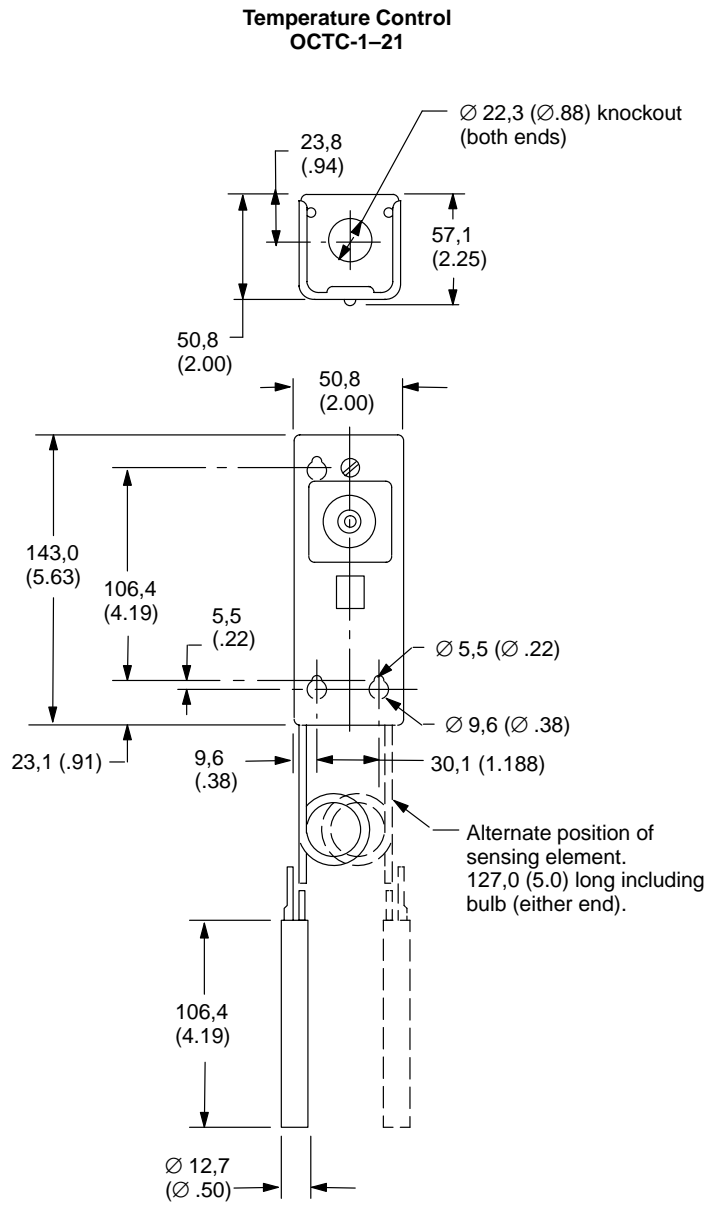

# Water-type Oil Coolers

## General Data

Vickers water-type coolers are adaptable to a wide range of oil cooling applications. They are of fixed tube bundle construction with an internal multiple fin arrangement on the shell side. The shells are made of brass for the OCW-1-B-30 cooler, and of steel for all other models.

Hydraulic fluid circulates through the cooler and around copper tubes containing the water. The water carries the heat away from the hydraulic fluid and can be regulated thermostatically to maintain a desired temperature. The cooler may be used as a heater by circulating hot water, rather than cold, through it.

Coolers are designed for one- or two-pass installations. See "Cooler Selection Procedure".

## Ratings

Maximum operating pressures are shown in the table below. The maximum operating temperature is 149° C (300° F). Flow data is shown in curves on the following page.

Maximum Operating Pressure – bar (psi)		
Cooler Model	Shell Side	Tube Side
OCW-1-B-30	14 (200)	10 (150)
OCW-S-2-F-30	34 (500)	
OCW-S-3-F-30		
OCW-S-5-F-30		
OCW-F-6-F-30	28 (400)	

## Cooler Selection Procedure

The size of the cooler required for a particular set of conditions can be selected from the curves on the following page. When entering water temperature is other than 29° C (85° F), the actual capacity of the cooler is greater or less than the curve values, depending upon whether the water temperature is respectively lower or higher. (See "CAUTION" note below curves chart.

When the required flow exceeds the maximum capacity of the largest cooler, two smaller coolers of equal size should be used in parallel.

**Example 1:** Assume an installation where the oil flow rate is 151 L/min (40 USgpm) and the cooler must remove 25 hp of the average duty cycle. The temperature of the available water is 29° C (85° F). As the curves are based on 29° C (85° F) entering water, the cooler can be selected directly from them. From the chart on the following page, determine the point of intersection of lines representing 151 L/min (40 USgpm) and 25 hp. By reading upward and/or to the left to the curve for the smaller cooler, it is seen that a model OCW-S-3-F-30 cooler should be used, and that the 4:1 (see explanation directly under curve) oil-to-water ratio indicates a minimum required water flow of 38 L/min (10 USgpm)

**Example 2:** Assume an installation where the oil flow rate is 208 L/min (55 USgpm) and the cooler must remove 35 hp of the average duty cycle. The entering water temperature is 35° C (95° F).

As indicated by the table of water temperature correction factors, capacity of a cooler with 35° C (95° F) water is only .7 of what it would be with 29° C (85° F) water. Therefore, divide the 35 hp by .7 and refer that value (50 hp) to the curves. Determine the point of intersection of lines representing 208 L/min (55 USgpm) and 50 hp, then read upward and/or to the left to the curve for the smaller cooler. Model OCW-F-6-F-30 satisfies these conditions. However, the curves show that model is capable of removing the 50 hp but cannot handle the 208 L/min (55 USgpm). By using a globe valve for bypassing a portion of the oil flow, or a check valve that has a cracking pressure equal to the  $\Delta P$  of the cooler which would result in the proper flow rate through the cooler, the smaller OCW-S-5-F-30 cooler could be used.

# Water-type Oil Coolers

## Cooler Sizing and Performance Curves

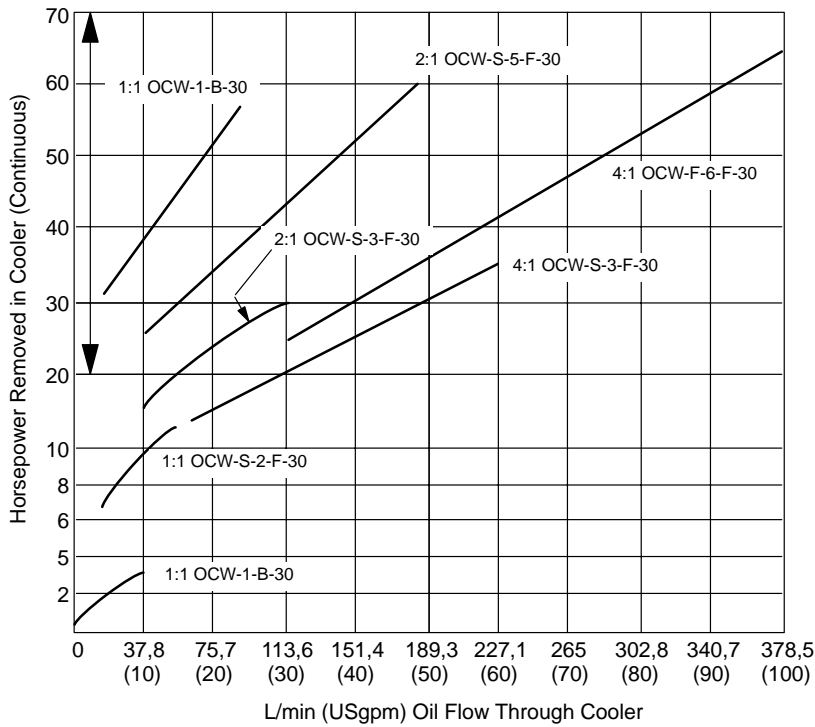

These capacities are based on an entering water temperature of 29°C (85°F) and a reservoir oil temperature of 52°C (125°F). Oil-to-water ratio of 1:1, 2:1 or 4:1 (preceding each cooler model number) means that for every gallon of oil circulated, a minimum of 1, 1/2 or 1/4 gallon (respectively) of water must be circulated to obtain the capacity shown on curve.

**CAUTION:** When the entering oil temperature is not 29°C (85°F), the desired horsepower removal value must be corrected for higher or lower temperatures before referring to these curves. See formula and chart below.

Temperature corrected by horsepower removal rate = horsepower to be removed by cooler ÷ by water temperature correction factor. See Example 2, preceding page.

Entering Water, °C (°F)	10 (50)	13 (55)	16 (60)	18 (65)	21 (70)	24 (75)	27 (80)	29 (85)	32 (90)	35 (95)	38 (100)
Correction Factor	1.8	1.7	1.6	1.5	1.3	1.2	1.1	1.0	.8	.7	.6

## Typical Pressure Drop Versus Flow Rate (Shell Side)

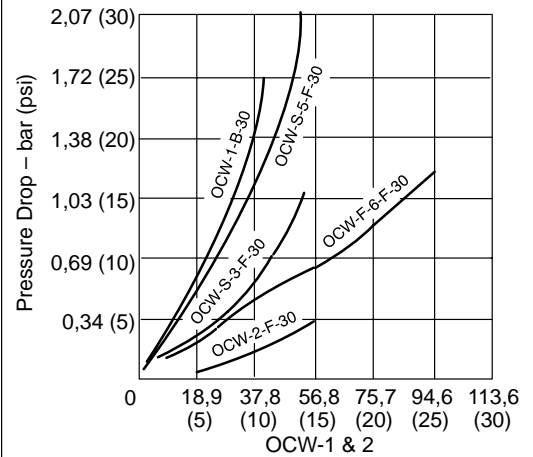

The pressure drop shown on the curves are for use with the above curves.

OCW-1-B-30 Cooler Model

Viscosity cSt (SUS)	Low Flow	Median Flow	Max. Flow
20 (100)	1.00	1.0	1.0
37 (175)	1.24	1.14	1.04
64 (300)	1.97	1.49	1.09
102 (475)	2.48	1.73	1.36

OCW-\*-F-30 Cooler Models

Viscosity cSt (SUS)	Low Flow	Median Flow	Max. Flow
20 (100)	1.00	1.00	1.00
37 (175)	1.75	1.68	1.42
64 (300)	3.17	3.00	2.34
102 (475)	5.33	4.50	3.54

# Water-type Oil Coolers

## Temperature Control & Bulb Well

The OCRV-1 temperature control valve is self-contained and is complete with thermostat bulb and capillary tube; it operates independently of any external power source.

 Click here for view of OCRV-1.

This is a modulating control and is not alternately open wide and shut tight. During normal operation, it remains in a constant, partially open position which is automatically adjusted whenever conditions require. The result is a uniform oil temperature for constant feed rates, etc.; water is conserved and the human factor eliminated.

To decrease the hydraulic fluid temperature, turn the control valve's calibration screw counterclockwise, 1/2 turn at a time; to increase, turn clockwise. Each adjustment will probably take 30 to 60 minutes to show as a change in reservoir oil temperature.

The temperature control valve should be installed in the water inlet line of the cooler. Do *not* use pipe wrenches for installing. A dent in the valve body or a sharp bend in the capillary may prevent

operation. Do not subject the control to water-hammer conditions or excessive pressures. The control opens on pressure rise.

The stainless steel bulb well (model OCBW-1-10) should be used when it's necessary to prevent corrosion, or so that the bulb can be removed without draining the reservoir. The bulb should be located where it will be most affected by temperature changes of the hydraulic fluid.

The temperature control and bulb well are not included with the cooler and must be ordered separately.

## Pressure Surges

Use a check valve with suitable cracking pressure, piped in parallel with the cooler, to provide overload protection against oil flow surges and resulting peak pressures.

## Fluids

Coolers are suitable for commonly used hydraulic fluids (in shell side where no seals are involved). For fire-resistant fluids, cooler sizing should

be reviewed by Vickers since temperature and heat removal characteristics vary with the type of fluid being cooled. Clean soft water should be used in the tube side. These coolers are *not* for use with high water base fluids. For HWBF applications, contact your Vickers representative.

## Strainer

An OCST-1 "Y" type brass strainer should be installed just ahead of the temperature control valve to protect it and the cooler from large particles of dirt. The strainer is cleanable by simply removing a pipe plug, and without disconnecting piping. For cleaning without service interruption, a blow-off valve can be connected to the cleanout opening.

## Standard Graphical Symbols for Fluid Power Diagrams

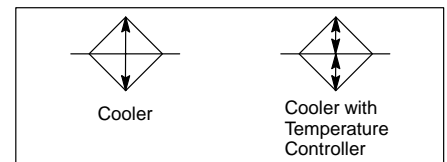

## Temperature Control and Strainer Sizing Chart

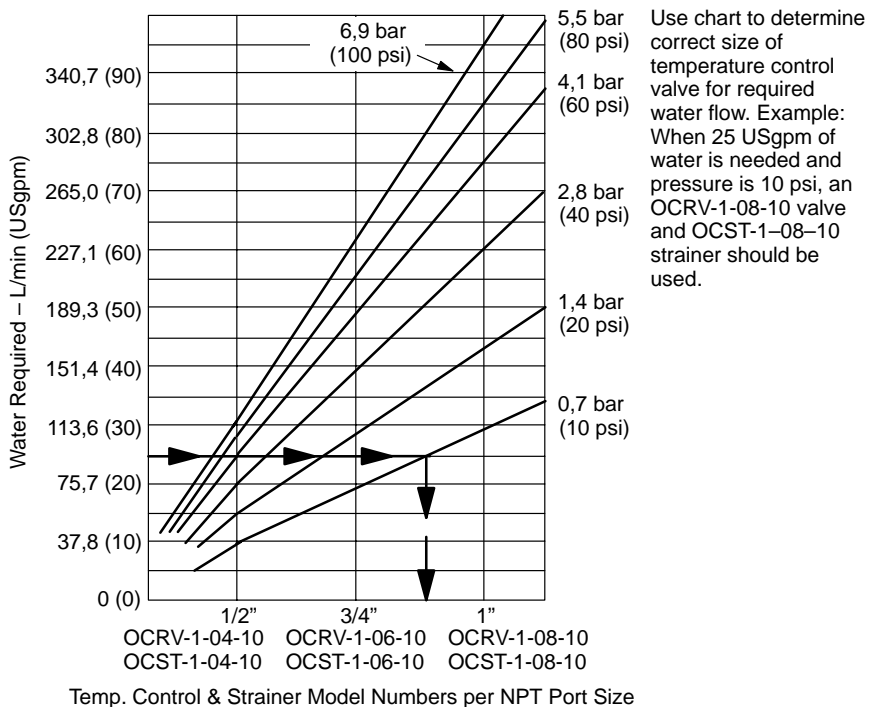

# Water-type Oil Coolers

## Dimensions in Millimeters (Inches)

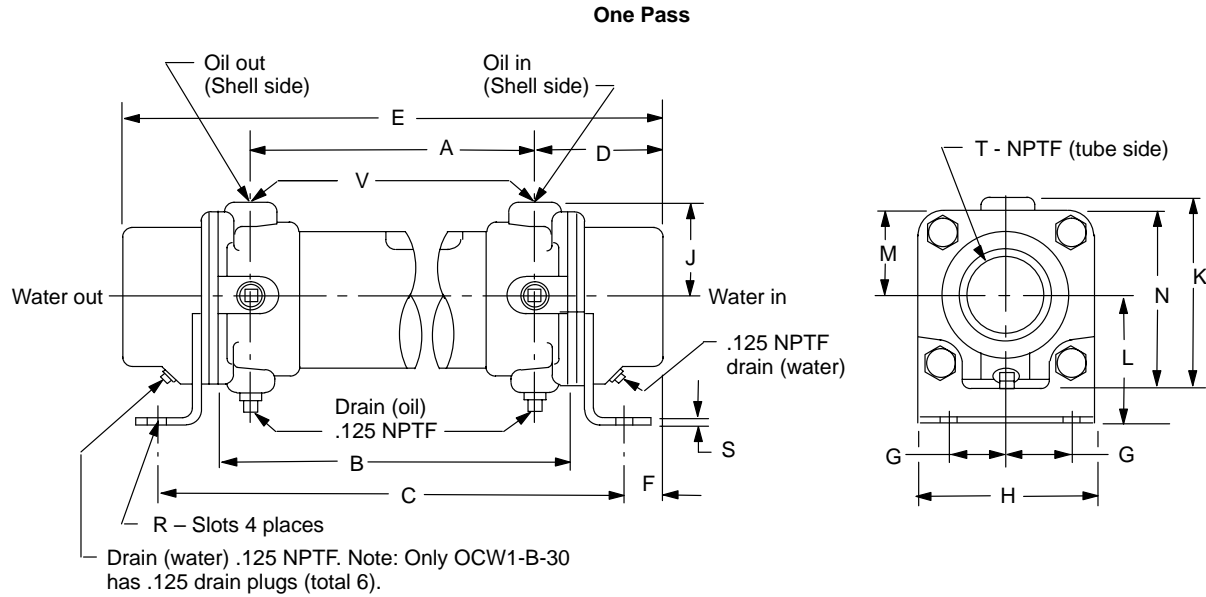

Model Number	Oil to Water Ratio	A	B	C	D	E	F	G	H	J
OCW-1-B-30	1:1	193,5 (7.62)	228,6 (9.0)	280,9 (11.06)	73,2 (2.88)	339,8 (13.38)	29,5 (1.16)	22,4 (.88)	66,5 (2.62)	39,6 (1.56)
OCW-S-2-F-30		146,3 (5.76)	203,2 (8.0)	260,6 (10.26)	57,2 (2.25)	258,8 (10.19)	1,0 (.04)	31,8 (1.25)	-	47,8 (1.88)

Model Number	K	L	M	N	R	S	T	V	Approx.Weight kg (lb)
OCW-1-B-30	71,4 (2.81)	47,8 (1.88)	31,8 (1.25)	63,5 (2.50)	∅ 9,6 (∅ .375)	1,9 (.075)	1.00-11.5 NPTF	.50-14 NPTF	2,3 (5.0)
OCW-S-2-F-30	84,1 (3.31)	41,1 (1.62)	36,6 (1.44)	73,2 (2.88)	8,6 × 12,7 (.34 × .50)	2,6 (.104)	.75-14 NPTF	1.0625- 12 UN	3,2 (7.0)

# Water-type Oil Coolers

Dimensions in Millimeters (Inches)

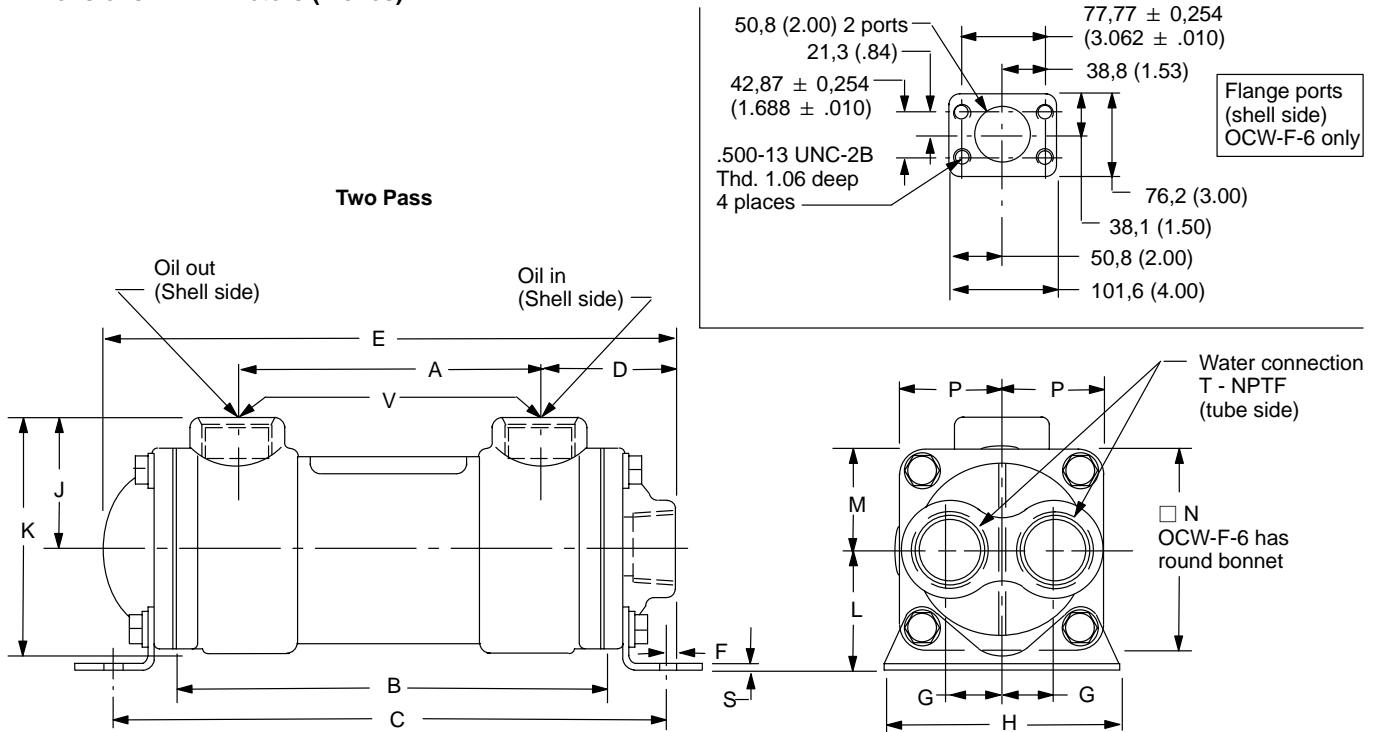

Model Number	Oil to Water Ratio	A	B	C	D	E	F	G	H	J
OCW-S-3-F-30	2:1 and 4:1	228,6 (9.0)	304,8 (12.0)	374,6 (14.75)	73,2 (2.88)	373,4 (14.7)	0,2 (.01)	38,1 (1.5)	76,2 (3.0)	66,5 (2.62)
OCW-S-5-F-30	1:1 and 2:1	381,0 (15.0)	457,2 (18.0)	527,0 (20.75)		525,8 (20.7)				
OCW-F-6-F-30	4:1	215,9 (8.5)	304,8 (12.0)	393,7 (15.50)	104,5 (4.51)	396,7 (17.02)	20,6 (.81)	50,8 (2.0)	165,1 (6.5)	88,9 (3.50)

Model Number	K	L	M	N	P	R	S	T	V	Approx. Weight kg (lb)
OCW-S-3-F-30	115,1 (4.53)	57,2 (2.25)	48,5 (1.91)	97,0 (3.82)	25,4 (1.00)	11,2 × 19,0 (.44 × .75)	2,6 (.104)	1.00-11.5 NPTF	1.625-	6,6 (14.5)
OCW-S-5-F-30									12 UN	
OCW-F-6-F-30	171.4 (6.75)	101,6 (4.00)	82,6 (3.25)	∅ 165,1 (∅ 6.5)	30,2 (1.19)	11,2 × 25,4 (.44 × 1.0)	3,0 (.120)	1.50-11.5 NPTF	2" SAE 4-bolt fig.	15,2 (33.5)

# Water-type Oil Coolers

## Dimensions in Millimeters (Inches)

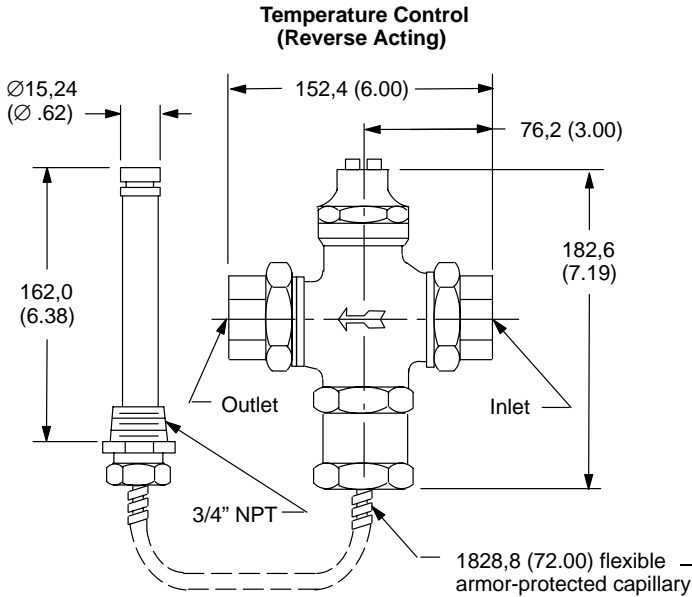

Temp. Control-Model Number	Inlet & Outlet NPT Thread Double Union	Pressure Rating bar (psi)	Temperature Range °C (°F)
OCRV-1-04-10	1/2"	0 to 8,6 (0 to 125)	41 to 63 (105 to 145)
OCRV-1-06-10	3/4"		
OCRV-1-08-10	1"		

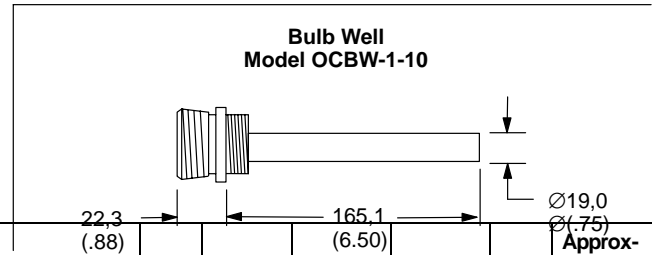

Model Number	A	B	C	D	E	Approx-Weight kg (lb)
OCST-1-04-10	1/2"	63,5 (2.50)	38,1 (1.500)	54,8 (2.156)	1/4"	0,45 (1)
OCST-1-06-10	3/4"	88,9 (3.50)	55,5 (2.187)	79,4 (3.125)	1/2"	0,90 (2)
OCST-1-08-10	1"					

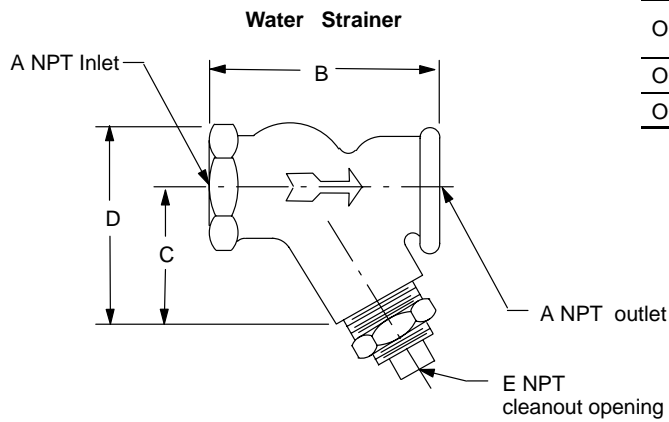

# Diaphragm Pressure Gages

## General Data

These compact gages are for use with Vickers series OFRS filters, or for monitoring low pressure hydraulic or pneumatic systems. They have a 0 to 8 bar (0 to 120 psig) range with a  $\pm 10\%$  accuracy, and are capable of withstanding pressures up to 27,5 bar (400 psig).

The gages have a steel case with a stainless steel bezel, and a white dial face. Two pressure ranges are shown on the face; bar numerals in blue, and psi in black. Scratch-resistant tempered glass is used over the gage face.

Two gage models are available: GM-120-2-10 (assembly no.736129) for stem mounting, and GP-120-2-10 (assembly no.593255) for panel mounting.

## Operating Pressure

The operating pressure range is 0 to 8 bar (0 to 120 psi).

## Installation

Certain applications require gage snubbing to prevent the gage from oscillating and to protect it from pressure surges. It is recommended that the gage be isolated from the hydraulic system with a shutoff valve to minimize excessive pressure surges and to allow it to be serviced without interrupting the hydraulic system.

## Fluids

All commonly used hydraulic fluids may be used.

## Weight

0,23 kg (.5 lb)

## Standard Graphical Symbol for Fluid Power Diagrams

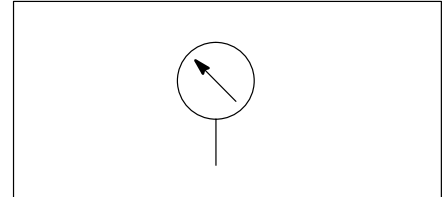

## Dimensions in Millimeters (Inches)

### Stem-mounting Model G M-120-2-10

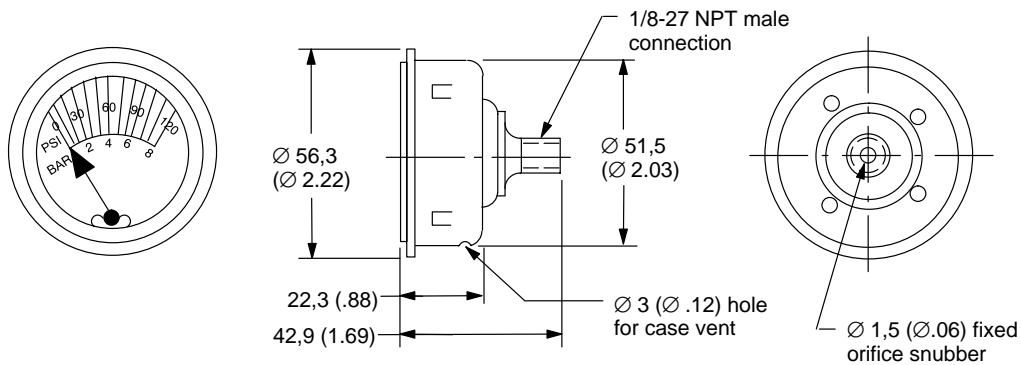

### Panel-mounting Model GP-120-2-10

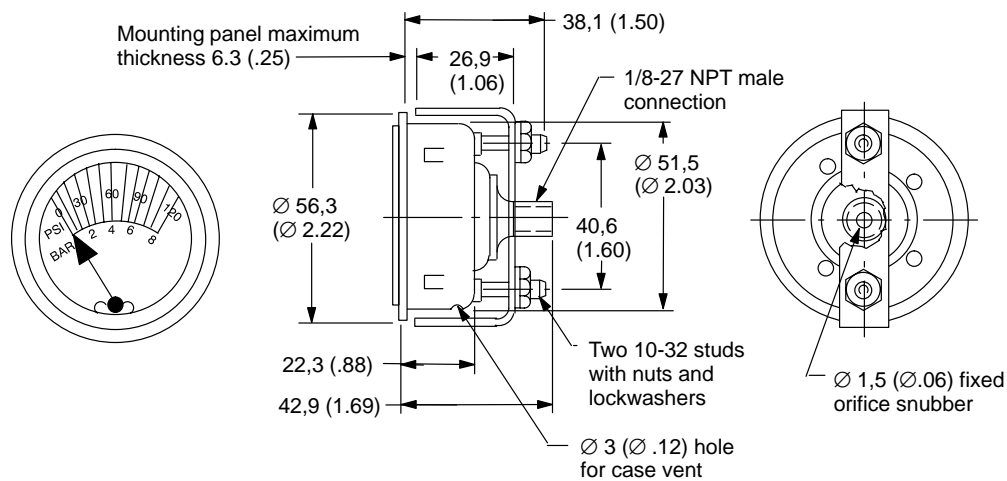



# Bourdon Tube Pressure Gages

## General Data

These gages are designed to be installed locally in a system, or flush mounted in a display panel. Available in 2-1/2 and 4-inch sizes, they provide optimum performance under severe operating conditions by minimizing the effects of hydraulic system pulsations and mechanical vibrations.

The gages are filled with glycerine – a stable viscous fluid which dampens the Bourdon tube, amplifying device, and pointer movement to ensure constantly accurate readings and long life. A fixed-orifice snubber within the gage's pressure connection also dampens pointer oscillation and protects the gage against damage from pressure surges.

All models have a safety blowout disc for operational safety. An acrylic window with a pressure equalizing membrane is employed to eliminate erroneous readings due to glycerine expansions or contractions resulting from ambient temperature changes.

All 2-1/2" gages have a cast brass case, and a slotted polished-brass bezel (or beauty ring) that's retained by a screw on each side of the gage. The 4" gage has a silver-sprayed case and chrome plated bezel.

## Operating Pressure

The gages are calibrated in both bar and psi, read zero at atmospheric pressure, and ignore atmospheric pressure throughout their pressure range. See chart below for pressure range, mounting, connection, and size combinations.

## Installation

Stem-mounting gages have a bottom connection that installs directly into a test point of the fluid system.

Panel-mounting gages have a rear connection and are flush mounted and secured in an equipment panel by a flange. The panel requires a 63,5 or 101,6 mm (2-1/2 or 4 in.) minimum diameter hole for the gage/flange assembly, which goes into the hole from the panel front. Three screw holes are required in the panel for fastening the flange to the panel. See following page for flange dimensions.

When a gage is installed permanently, a shutoff valve or gage isolator should also be installed. This will prolong gage life by isolating the gage from the hydraulic system, except when taking a reading, and will allow gage servicing without interrupting the system.

## Panel-mounting Flange

A panel-mounted gage requires the use of a mounting flange: model FGP-2-30 for a 2-1/2" gage, or FGP-4-30 for a 4" gage. Stem-mounting gages can also be panel mounted by using these flanges.

The flange replaces the bezel that's shipped with the gage, and is retained by two screws on the gage. Flanges are not furnished with any gage and must be purchased separately.

## Fluids

All commonly used hydraulic fluids may be used.

## Weight

See dimensions chart, following page.

## Standard Graphical Symbol for Fluid Power Diagrams

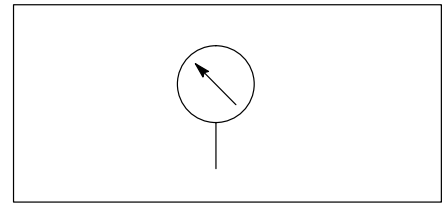

Mounting Type	Pressure Range		Model Number	
	bar	psi	2-1/2 inch	4 inch
Panel Mounting with Pipe Thread Connection	0 to 41 0 to 69 0 to 102 0 to 205 0 to 340	0 to 600 0 to 1000 0 to 1500 0 to 3000 0 to 5000	GP-600-30 GP-1000-30 GP-1500-30 GP-3000-30 GP-5000-30	Not Available
Stem Mounting with Pipe Thread Connection	-1 to +2 0 to 2.05 0 to 4.1 0 to 11 0 to 41	-30 in. Hg to +30 psi 0 to 30 0 to 60 0 to 160 0 to 600	GM-30-30 GM-030-30 GM-60-30 GM-160-30 GM-600-30	- - - GM-160-4-30 -
	0 to 69 0 to 102 0 to 135 0 to 205 0 to 340	0 to 1000 0 to 1500 0 to 2000 0 to 3000 0 to 5000	GM-1000-30 GM-1500-30 GM-2000-30 GM-3000-30 GM-5000-30	- GM-1500-4-30 - GM-3000-4-30 GM-5000-4-30
Stem Mounting with Straight Thread Connection	0 to 69 0 to 102 0 to 205 0 to 340	0 to 1000 0 to 1500 0 to 3000 0 to 5000	GM-S-1000-30 GM-S-1500-30 GM-S-3000-30 GM-S-5000-30	Not Available

# Bourdon Tube Pressure Gages

Dimensions in Millimeters (Inches)

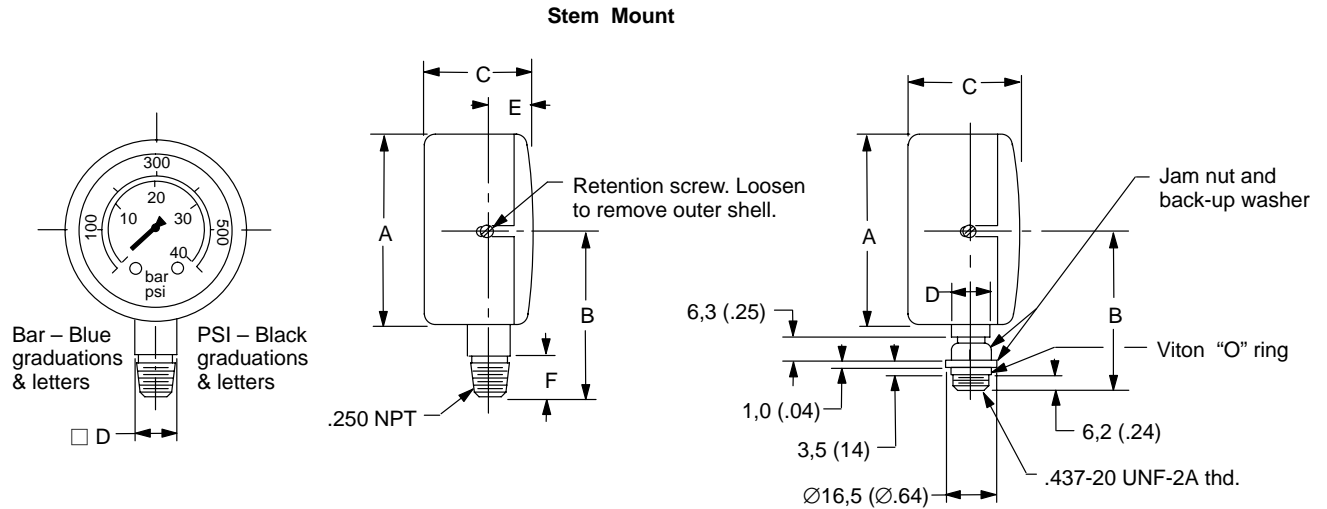
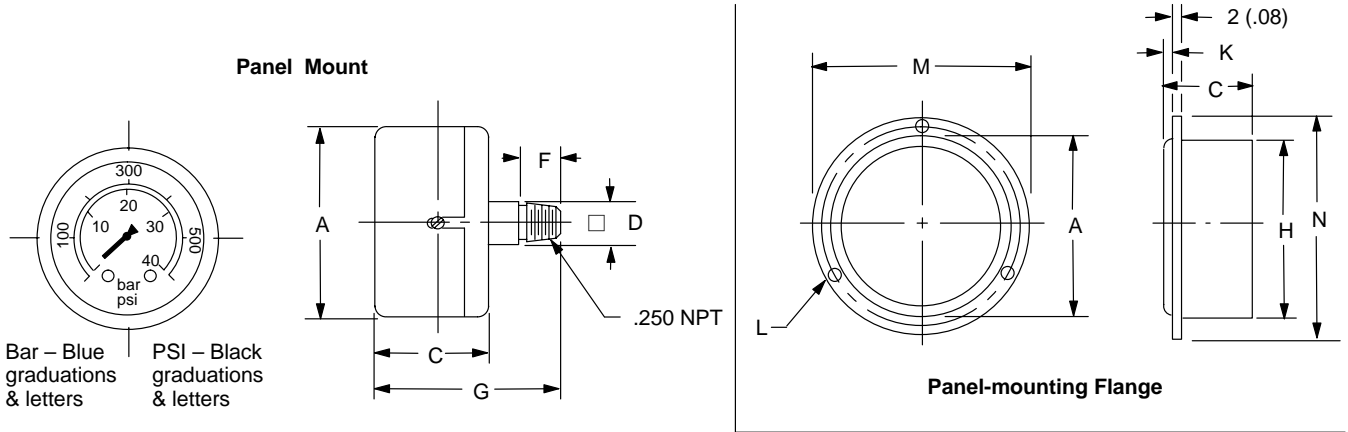

Gage Model Number	A	B	C	D	E	F	G	Approximate Weight kg (lb)
GP-****-30	63 (2.5)	53 (2.09)	37 (1.46)	14 (.55)	11 (.43)	13 (.51)	63 (2.48)	0,34 (.75)
GM-****-30							–	
GM-****-4-30	100 (4)	80 (3.15)	49 (1.93)	22 (.87)	13.5 (.53)	–	74 (2.91)	1,13 (2.5)
GM-S-****-30	63 (2.5)	55 (2.16)	37 (1.46)	14 (.55)	11 (.43)	–	–	0,34 (.75)

Flange Model Number	A	C	H	K	L	M	N
FGP-2-30	63 (2.5)	37 (1.46)	62.3 (2.45)	2 (.08)	3.5 (.14)	75 (2.95)	85 (3.35)
FGP-4-30	100 (4)	49 (1.93)	99.2 (3.9)	3.5 (.14)	5 (.20)	115 (4.53)	132 (5.20)

# Spring-loaded Pressure Gages

## General Data

These gages are used in hydraulic systems when it is desirable to continuously monitor system pressures throughout constantly changing cycles. They are also helpful in setting system pressure controls and assessing the output performance of hydraulically operated machines. No needle valve, snubber, or gage isolator is needed to apply the gage.

The gages are available with two types of pressure indicator. One allows pressure to be read in both bar and psi. The other is color coded to show whether system pressure is within an acceptable operating range, making it suitable for systems wherein a specific pressure need not be known. Either gage can be mounted anywhere in a system – at any angle – and is readable from any point within a 360 degree field of vision.

## Pressure Ranges

The operating pressure ranges for numerically calibrated models are:

Model Number	Calibrated Pressure Range	
	bar	psi
GS-1000-20	14–70	200–1000
GS-2000-20	28–140	400–2000
GS-3000-20	35–210	500–3000

See chart below for pressure ranges of color coded models.

The maximum pressure range selected with either type of gage should be well above anticipated peak pressure to prevent damage; however, excess range decreases the accuracy of readings.

## Installation

Certain applications require gage snubbing to prevent the gage from oscillating and to protect it from pressure surges. It is recommended that the gage be isolated from the hydraulic system with a shutoff valve to minimize excessive pressure surges and to allow it to be serviced without interrupting the hydraulic system.

## Fluids

All commonly used hydraulic fluids may be used.

## Standard Graphical Symbol for Fluid Power Diagrams

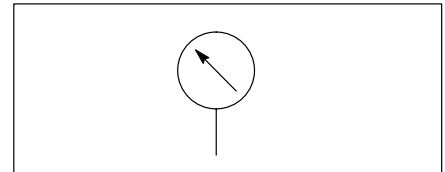

Model Number	Pressure Range/Color Band*					
	Green		Yellow		Red	
	bar	psi	bar	psi	bar	psi
GS-1000-C-20	0–24	0–350	24–48	350–700	48–70	700–1000
GS-2000-C-20	0–48	0–700	48–96	700–1400	96–140	1400–2000
GS-3000-C-20	0–70	0–1000	70–140	1000–2000	140–210	2000–3000

\* System pressure uncovers green band (preferred range) first. As pressure rises, yellow (caution) appears, followed by red (unacceptable). Bands are recovered as pressure falls.

## Dimensions in Millimeters (Inches)

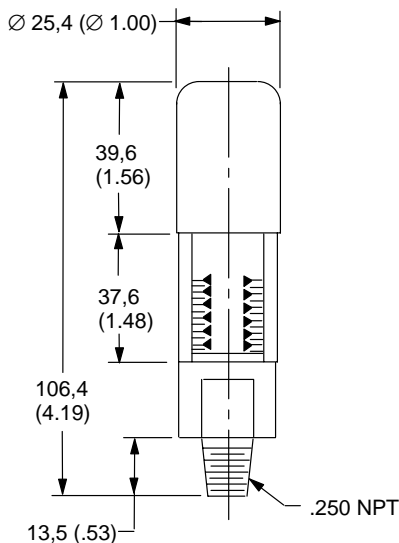

### Calibrated Models

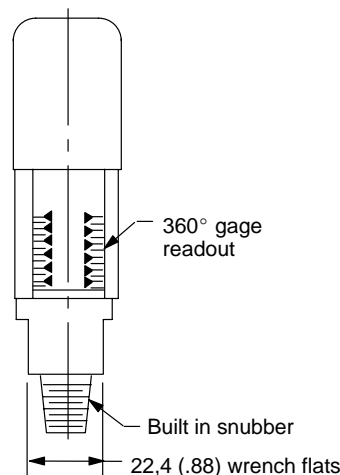

### Color Coded Models

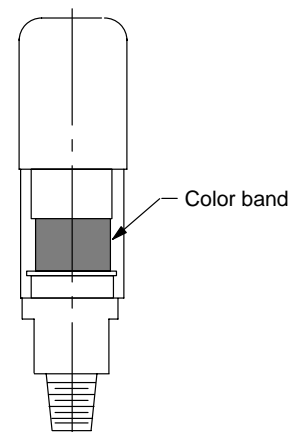

# Reservoir Filler-breather

## Model Number SP-113-C

This unit provides a means of filling the system reservoir and allows air to exit or enter the space above the fluid as the

fluid level rises or falls. It incorporates an air filter, and a wire screen to prevent foreign matter from entering the reservoir during filling. The cap is attached to the neck of the filler by a

chain to prevent the cap from being lost or misplaced.

### Dimensions in Millimeters (Inches)

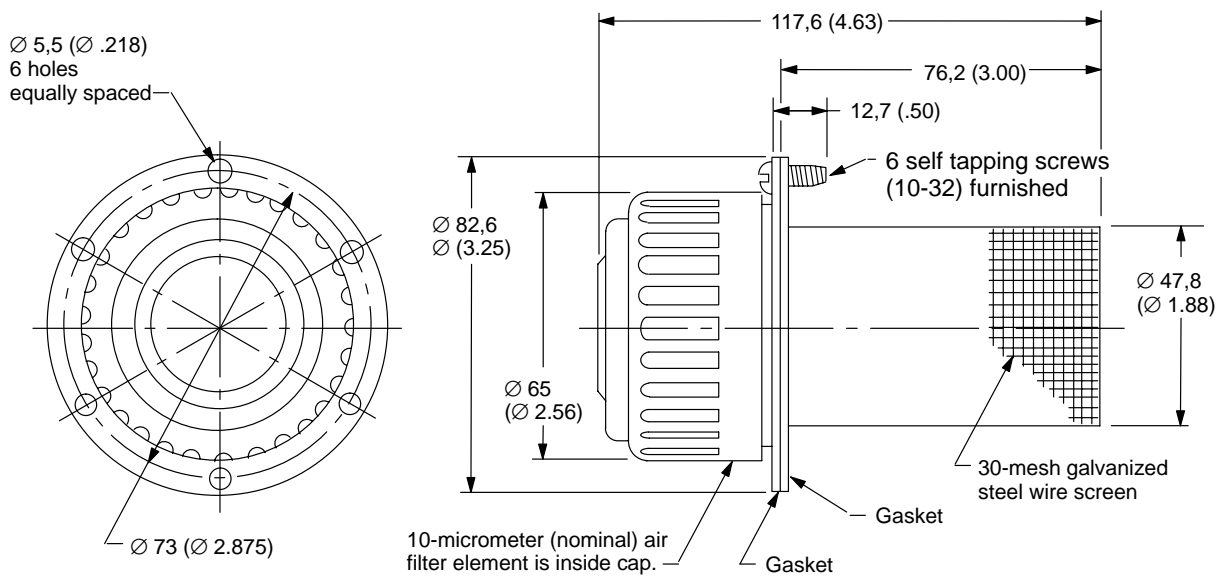

# Vacuum and Pressure Switches

These switches actuate a remote indicating device by making electrical contact when a preselected pressure setting is reached. They are for general use in low pressure hydraulic circuits, and are often used to tell when a filter's element should be replaced

(by indicating a rising pressure differential across the element).

Two styles of electrical connection are available: wire leads (style "A"), or terminal screws (style "B"). Style "A" has a 1/2 inch female pipe connection for conduit to run wires from the leads.

**Caution:** Consult local electrical codes when using the style "B" design. Use of an insulation boot is recommended with this switch.

## Dimensions in Millimeters (Inches)

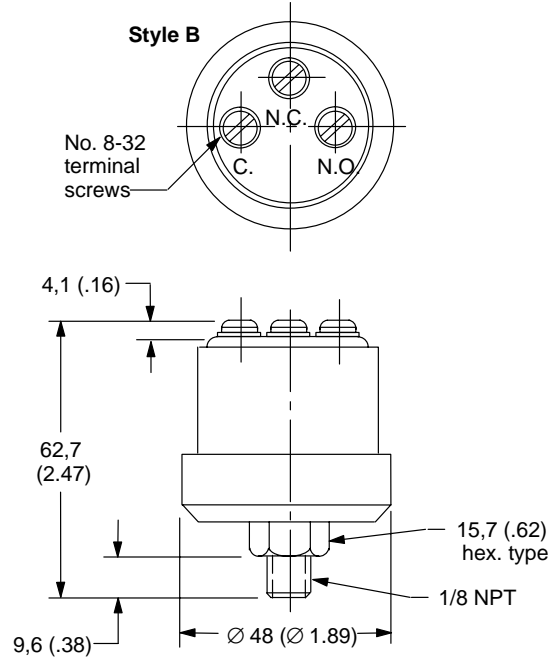
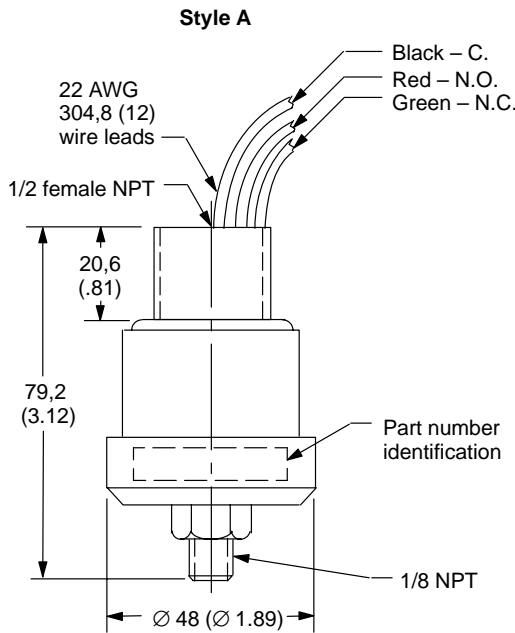

## Electrical Indicating Switch Circuit

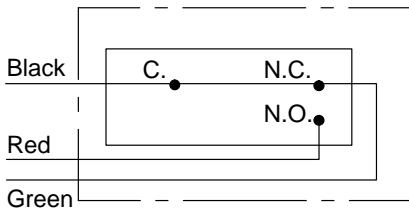

Part No.	Type	Style	Pressure Setting	Adjustable Range - bar (psi)
736349	Pressure	A	1,7 bar (25 psi)	1-2,4 (15-35)
736350	Pressure	B	1,7 bar (25 psi)	1-2,4 (15-35)
736351	Pressure	A	3,4 bar (50 psi)	2,1-5,2 (30-75)
736352	Pressure	B	3,4 bar (50 psi)	2,1-5,2 (30-75)
736353	Vacuum	A	5 in. Hg (2.5 psi)	Non-adjustable
736354	Vacuum	B	5 in. Hg (2.5 psi)	Non-adjustable

## Electrical Data

Pressure Switch - 10 Amps, 28 Vdc. 10 Amps, 125/250 Vac

Vacuum Switch - 5 Amps res., 3 Amps ind., 28 Vdc. UL listed 5 Amps, 250 Vac

Circuitry - SDPT

Housing Material - 40% glass filled nylon

Diaphragm Material - Epichlorohydrin

Алматы (7273)495-231  
Ангарск (3955)60-70-56  
Архангельск (8182)63-90-72  
Астрахань (8512)99-46-04  
Барнаул (3852)73-04-60  
Белгород (4722)40-23-64  
Благовещенск (4162)22-76-07  
Брянск (4832)59-03-52  
Владивосток (423)249-28-31  
Владикавказ (8672)28-90-48  
Владимир (4922)49-43-18  
Вологда (8172)26-41-59  
Воронеж (473)204-51-73  
Екатеринбург (343)384-55-89

Иваново (4932)77-34-06  
Ижевск (3412)26-03-58  
Иркутск (395)279-98-46  
Казань (843)206-01-48  
Калининград (4012)72-03-81  
Калуга (4842)92-23-67  
Кемерово (3842)65-04-62  
Киров (8332)68-02-04  
Коломна (4966)23-41-49  
Кострома (4942)77-07-48  
Краснодар (861)203-40-90  
Красноярск (391)204-63-61  
Курск (4712)77-13-04  
Курган (3522)50-90-47  
Липецк (4742)52-20-81

Магнитогорск (3519)55-03-13  
Москва (495)268-04-70  
Мурманск (8152)59-64-93  
Набережные Челны (8552)20-53-41  
Нижний Новгород (831)429-08-12  
Новокузнецк (3843)20-46-81  
Ноябрьск (3496)41-32-12  
Новосибирск (383)227-86-73  
Омск (3812)21-46-40  
Орел (4862)44-53-42  
Оренбург (3532)37-68-04  
Пенза (8412)22-31-16  
Петрозаводск (8142)55-98-37  
Псков (8112)59-10-37  
Пермь (342)205-81-47

Ростов-на-Дону (863)308-18-15  
Рязань (4912)46-61-64  
Самара (846)206-03-16  
Санкт-Петербург (812)309-46-40  
Саратов (845)249-38-78  
Севастополь (8692)22-31-93  
Саранск (8342)22-96-24  
Симферополь (3652)67-13-56  
Смоленск (4812)29-41-54  
Сочи (862)225-72-31  
Ставрополь (8652)20-65-13  
Сургут (3462)77-98-35  
Сыктывкар (8212)25-95-17  
Тамбов (4752)50-40-97  
Тверь (4822)63-31-35

Тольятти (8482)63-91-07  
Томск (3822)98-41-53  
Тула (4872)33-79-87  
Тюмень (3452)66-21-18  
Ульяновск (8422)24-23-59  
Улан-Удэ (3012)59-97-51  
Уфа (347)229-48-12  
Хабаровск (4212)92-98-04  
Чебоксары (8352)28-53-07  
Челябинск (351)202-03-61  
Череповец (8202)49-02-64  
Чита (3022)38-34-83  
Якутск (4112)23-90-97  
Ярославль (4852)69-52-93

Россия +7(495)268-04-70

Казахстан +7(7172)727-132

Киргизия +996(312)96-26-47

<https://vickers.nt-rt.ru> || [vsh@nt-rt.ru](mailto:vsh@nt-rt.ru)