

Алматы (7273)495-231
Ангарск (3955)60-70-56
Архангельск (8182)63-90-72
Астрахань (8512)99-46-04
Барнаул (3852)73-04-60
Белгород (4722)40-23-64
Благовещенск (4162)22-76-07
Брянск (4832)59-03-52
Владивосток (423)249-28-31
Владикавказ (8672)28-90-48
Владимир (4922)49-43-18
Волгоград (844)278-03-48
Вологда (8172)26-41-59
Воронеж (473)204-51-73
Екатеринбург (343)384-55-89

Иваново (4932)77-34-06
Ижевск (3412)26-03-58
Иркутск (395)279-98-46
Казань (843)206-01-48
Калининград (4012)72-03-81
Калуга (4842)92-23-67
Кемерово (3842)65-04-62
Киров (8332)68-02-04
Коломна (4966)23-41-49
Кострома (4942)77-07-48
Краснодар (861)203-40-90
Красноярск (391)204-63-61
Курск (4712)77-13-04
Курган (3522)50-90-47
Липецк (4742)52-20-81

Магнитогорск (3519)55-03-13
Москва (495)268-04-70
Мурманск (8152)59-64-93
Набережные Челны (8552)20-53-41
Нижний Новгород (831)429-08-12
Новокузнецк (3843)20-46-81
Ноябрьск (3496)41-32-12
Новосибирск (383)227-86-73
Омск (3812)21-46-40
Орел (4862)44-53-42
Оренбург (3532)37-68-04
Пенза (8412)22-31-16
Петрозаводск (8142)55-98-37
Псков (8112)59-10-37
Пермь (342)205-81-47

Ростов-на-Дону (863)308-18-15
Рязань (4912)46-61-64
Самара (846)206-03-16
Санкт-Петербург (812)309-46-40
Саратов (845)249-38-78
Севастополь (8692)22-31-93
Саранск (8342)22-96-24
Симферополь (3652)67-13-56
Смоленск (4812)29-41-54
Сочи (862)225-72-31
Ставрополь (8652)20-65-13
Сургут (3462)77-98-35
Сыктывкар (8212)25-95-17
Тамбов (4752)50-40-97
Тверь (4822)63-31-35

Тольятти (8482)63-91-07
Томск (3822)98-41-53
Тула (4872)33-79-87
Тюмень (3452)66-21-18
Ульяновск (8422)24-23-59
Улан-Удэ (3012)59-97-51
Уфа (347)229-48-12
Хабаровск (4212)92-98-04
Чебоксары (8352)28-53-07
Челябинск (351)202-03-61
Череповец (8202)49-02-64
Чита (3022)38-34-83
Якутск (4112)23-90-97
Ярославль (4852)69-52-93

Россия +7(495)268-04-70

Казахстан +7(7172)727-132

Киргизия +996(312)96-26-47

<https://vickers.nt-rt.ru> || vsh@nt-rt.ru

Vickers®

Pressure Relief

Pressure Relief Valves

Remote Controls, Relief and Sequence Valves, and Single and Multiple Pressure Solenoid and Air Operated Relief Valves



Introduction

Remote Controls

Small, easily installed remote pressure control valves make it possible to control a balanced piston pressure relief valve from a more convenient location.

Relief and Sequence Valves

Pressure relief valves mount between the pump and valve system to protect against overloads. A suitable pilot valve may be used to “vent” the balanced piston relief valve when the system does not require power. This venting unloads the pump through the relief valve at low pressure, avoiding energy waste and reducing operating costs.

A sensitive adjustment mechanism allows the setting of the pressure in fine increments over a wide range — up to the maximum rating of the valve.

Stepped relief valves at the control console or other remote location, and elimination of separately mounted hydraulic remote controls and related connecting piping, result in lower installed cost. The valves are available with SAE straight threads, NPT threads, or interfaces for manifold or subplate mounting to provide no-leak connections.

Single and Multiple Pressure Solenoid and Air Operated Valves

These balanced piston type valves are used in applications needing an electrically or pneumatically controlled adjustable pressure relief or regulating valve to limit the pressure in a hydraulic circuit to the desired maximum.

Table of Contents

Series CGE-02/06/10 Remote/Electrically Modulated Controls	3
Series CGR-02 Remote Controls	9
Series C-175 Remote Control/Relief Valves	11
Series CG-03 Relief Valves	13
Series C*-03/06/10 Relief/Sequence Valves	16
Series CG-06/10 Relief/Sequence Valves	20
Series CGAM-06/10 Adapter Mounting Plates	26
Series C*5-03/06/10 Pilot Operated Relief Valves	28
Series C*19-06/10 Air Operated Relief Valves	38
Series C*-06/10-DG Bi/Tri-Pressure Relief Valves	47
Series C*-06/10-DG-M-M Bi/Tri-Pressure Relief Valves	55
Application Data	61

Series Model CGE-02/06/10

Remote/Electrically Modulated Controls

Model Code

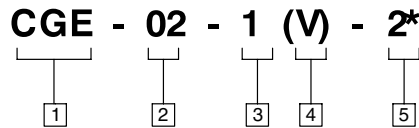

1 Model Series

CGE - Relief valve, manifold or subplate mounted, remote electrically modulated

3 Pressure Rating

1 - 70 bar (1000 psi)
3 - 210 bar (3000 psi)

5 Design Number

Subject to change. Installation dimensions remain as shown for design numbers 20 through 29

2 Valve Size

02 - NFPA-DO3 (ISO-4401-03) interface
06 - 60 series (3/4" nominal size)
10 - 100 series (1-1/4" nominal size)

4 High Vent Spring

(For CGE-06 & -10 3000 psi pressure models only). Omit if not required.

General Information

The CGE-02 valve provides the capability to modulate system pressure when connected to a relief or reducing valve or regulating the pressure setting of a pressure compensator variable displacement pump.

The CGE-06/10 provides the capability to modulate system pressure using a remote electrical controller. The pressure setting of the valve is approximately proportional to input current; increasing current provides increasing pressure.

Manual Operation

A manual override adjustment of the CGE-06/10 operates over the full pressure range and should be set just above the maximum pressure to be controlled electrically. For example, the override should be set at 2200 psi when maximum electrically controlled pressure is 2000 psi.

The override adjustment can also be used for complete manual operation of the valve during set up and troubleshooting by isolating the pilot head section from the manual override section. This is done by removing an access plug and reversing a button in the pilot section (see fig. 1).

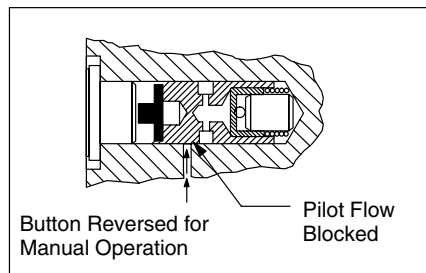

Figure 1

Electrical Power Supply

Vickers power supply EMCS*-30 is recommended for controlling this valve. Figure 2 shows the basic diagram (amplifier switch should be in position 1).

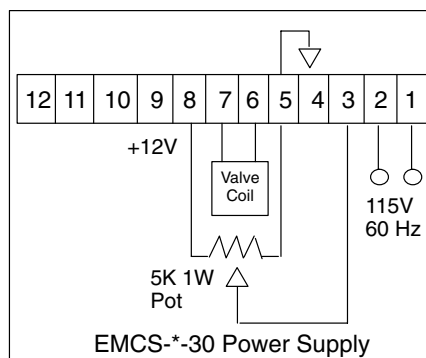

Figure 2

Tank Connection

The tank connection should be piped directly to tank through a surge free line to minimize back pressure. If tank line back pressure exceeds system pressure by 7 bar (100 psi) a malfunction may occur. Any pressure in the tank line is an additive when the valve is controlled by the manually adjusted (non-electrical) head.

Pilot Drain Connection

Drain line must be full size unrestricted and connected directly to reservoir so that it terminates below reservoir fluid level. No other lines are to be connected to this drain line. Pressure in this line (taken at the valve) not to exceed 1 bar (15 psi).

Graphical Symbol

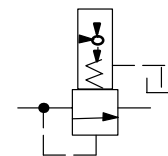

Minimum Pressure Specifications (Zero Current)

Model	Flow		Minimum Pressure	
	L/min	USgpm	bar	PSI
CGE-06-1-2*	76	20	5.2	75
CGE-06-3*-2*			10.4	150
CGE-06-3V-2*			20.7	300
CGE-10-1-2*	189	50	5.2	75
CGE-10-3-2*			10.4	150
CGE-10-3V-2*			20.7	300

Series Model CGE Remote/Electrically Modulated Controls

Installation Data

Filter Screen

The CGE-02 valve contains a filter screen in the pressure port of the valve head (fig. 3) which may require periodic cleaning, depending on system cleanliness.

The CGE-06/10 valves contains a filter screen in the pressure port of the valve head (fig. 3) and an additional screen in the valve body (fig. 4). Both require periodic cleaning depending on system cleanliness.



WARNING

Before breaking a circuit connection, make certain that power is off and system pressure has been released. Lower all vertical cylinders, discharge accumulators and block any load whose movement could generate pressure. Plug all removed units and cap all lines to prevent the entry of dirt into the system.

To remove the filter screen from the valve head (fig. 3), first shut down the machine and remove the access plug, button, spool and screen. Clean screen and reassemble.

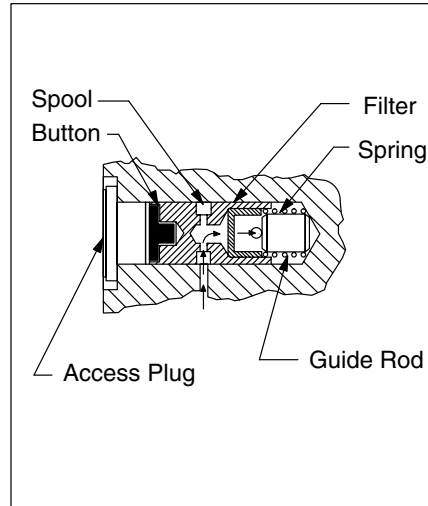

Figure 3

To remove the filter screen from the valve body (fig. 4), first shut down the machine and remove the relief valve from the pump. Remove the snap ring and screen. Clean screen and reassemble.

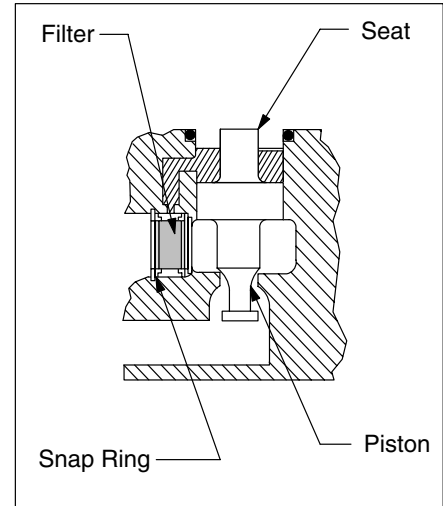

Figure 4

Ratings

The CGE Series are rated for a maximum pressure of 210 bar (3000 psi). The table on page 3 lists minimum pressures attainable when the CGE is used with three sizes of system relief valves at various system flows.

Pressure and Flow (see tables on right)
Pressure change due to temperature:

The maximum pressure deviation between 26.7°C (80°F) and 65.6°C (150°F) is 4.8 bar (70 psi).

Hysteresis:

5% of maximum current (without dither-see curves on pages 5-7)

3% of maximum current (with dither)

Recommended dither:

10 mA (RMS) at 60 Hz

Power required (maximum): 5.75 watts

Nominal coil resistance: 18 ohms

Current required:

0-500 mA DC (not polarity sensitive)

Response Time

For response time, see tables below. Note that response time will increase with increasing flows. Also response time is dependent on the amount of all volume in the pressure side of the circuit; less oil volume under pressure will result in faster response times.

Step input currents of less magnitude will decrease response time proportionally. Decreasing pressure response will be approximately 1/4 of response time values.

Note

Response times shown are typical of those experienced with an average volume of oil under compression. For small volumes of oil under compression (20-40 cubic inches), response times are 60-80 ohms.

Pressure & Flow Ratings

Model	Maximum Pressure bar (psi)	Maximum Flow L/min (USgpm)
CGE-02-1	70 (1000)	1.9 (0.5)
CGE-02-3	210 (3000)	
CGE-06-1-2*	70 (1000)	170 (45)
CGE-06-3*-2*	210 (3000)	
CGE-10-1-2*	70 (1000)	380 (100)
CGE-10-3*-2*	210 (3000)	

Minimum Controllable Flows

Model	L/min	USgpm
CGE-06-*-2	7.6	2
CGE-10-*-2	11.4	3

Response Time, typical

Model	Step input mA	Flow		Pressure Increase		Response Time-ms
		L/min	USgpm	bar	PSI	
CGE-06-1-2*	0-500	76	20	5-70	75-1000	250
CGE-06-3*-2*				10-210	150-3000	290
CGE-10-1-2*		189	50	5-70	75-1000	400
CGE-10-3*-2*				10-210	150-3000	240

Performance Curves

CGE-02-3-20

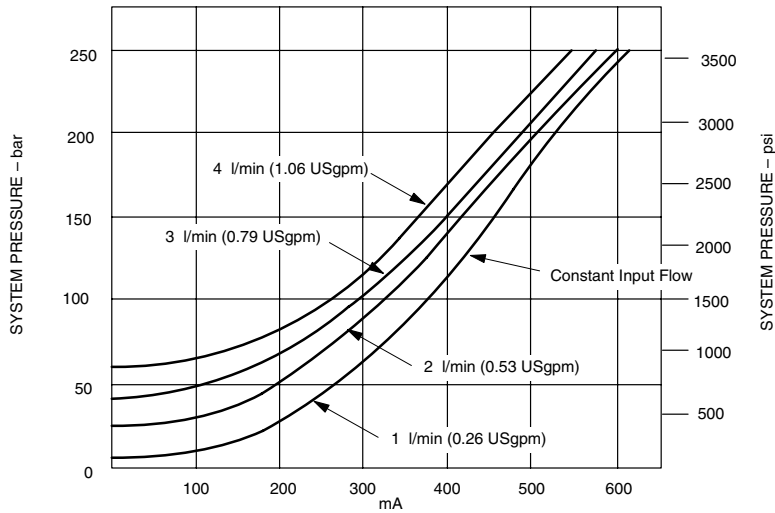

CGE-06-3-2*

Flow – 76 L/min (20 USgpm)
Pressure vs Current

CGE-06-3V-2*

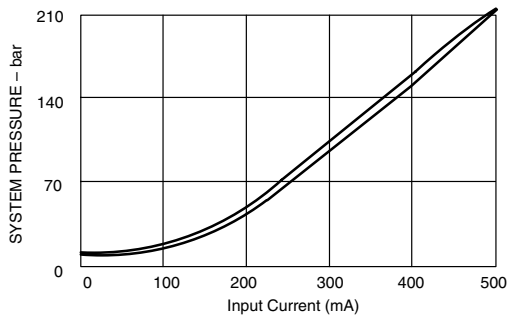

Pressure vs System Flow

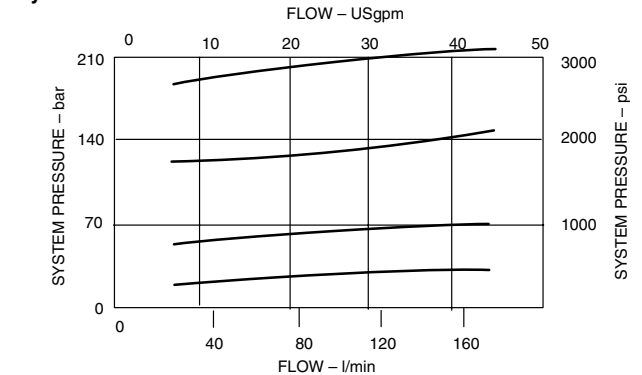
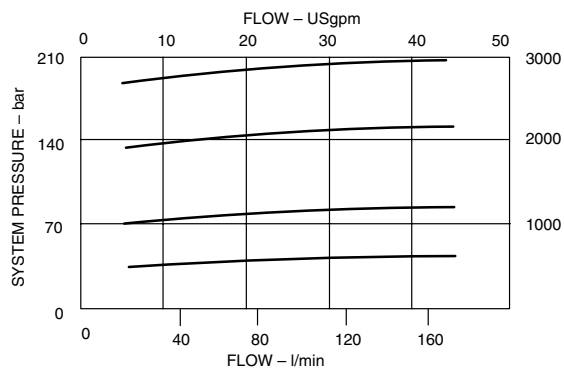
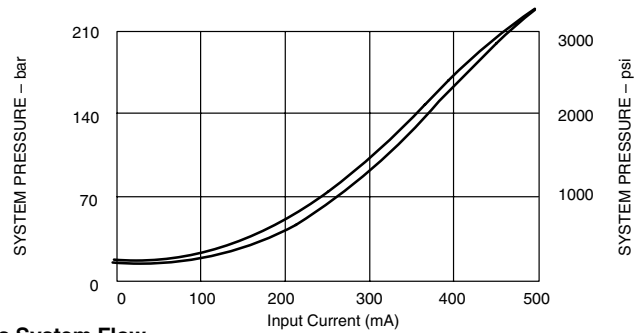

Minimum Pressure vs System Flow

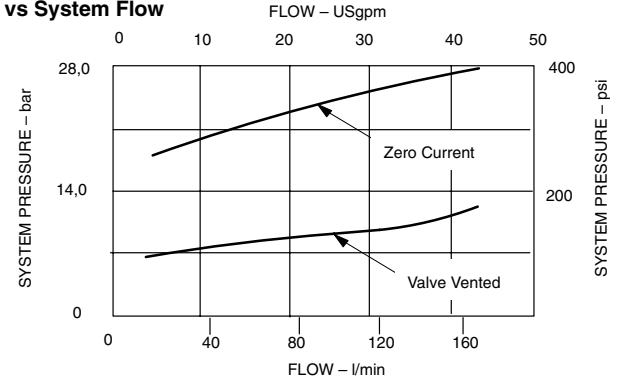
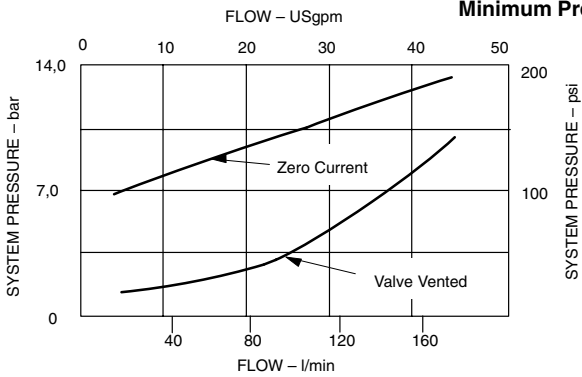

Performance Curves

CGE-06-1-2*

Flow – 76 L/min (20 USgpm)

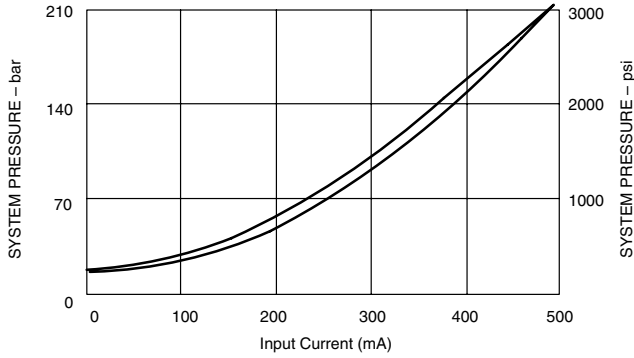

CGE-10-3-2*

Flow – 189 L/min (50 USgpm)

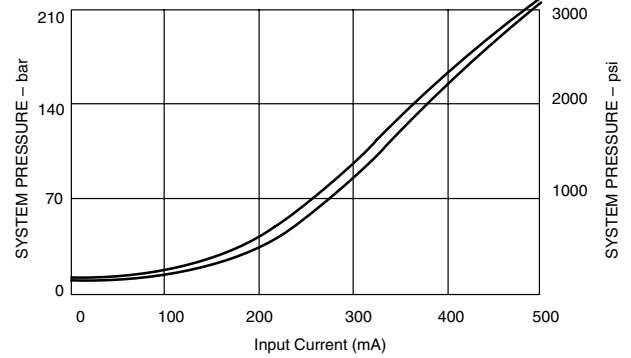

Pressure vs System Flow

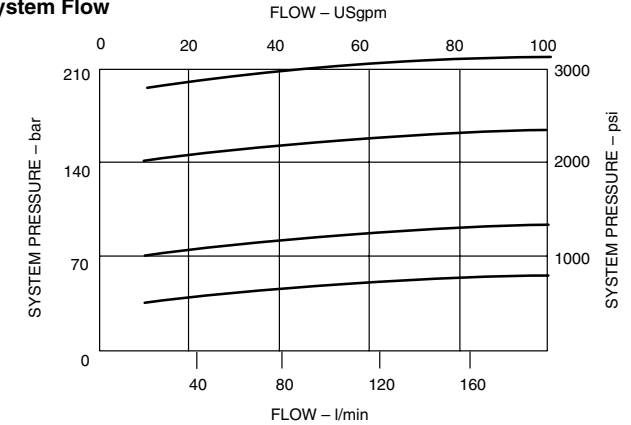
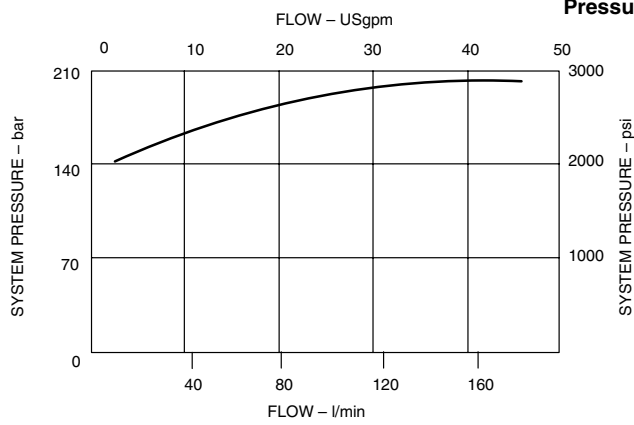

Minimum Pressure vs System Flow

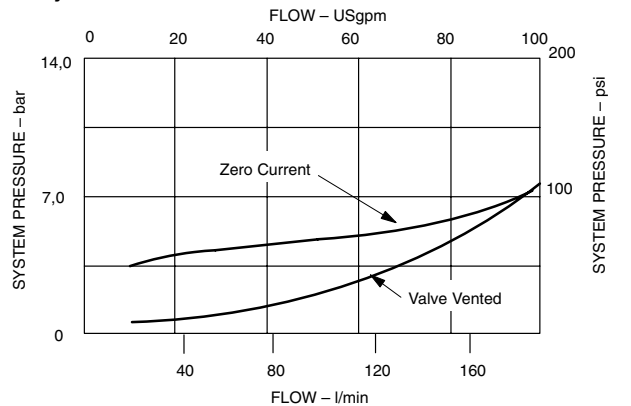
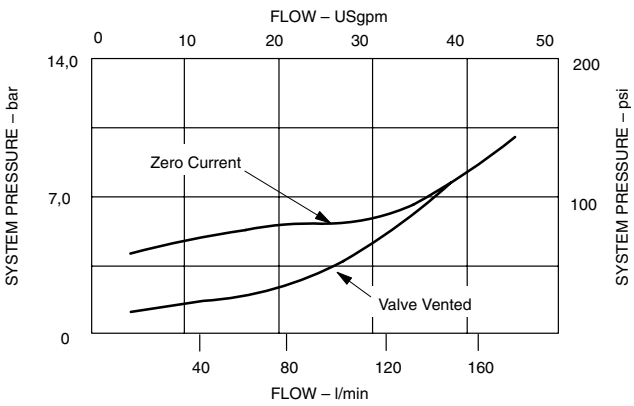

CGE-10-3V-2*

Flow – 189 L/min (50 USgpm)
Pressure vs Current

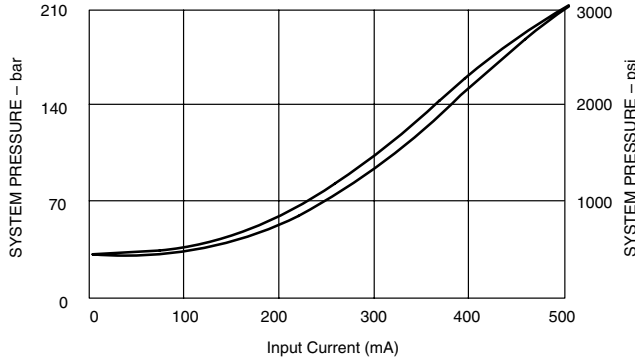

CGE-10-1-2*

Flow – 189 L/min (50 USgpm)
Pressure vs Current

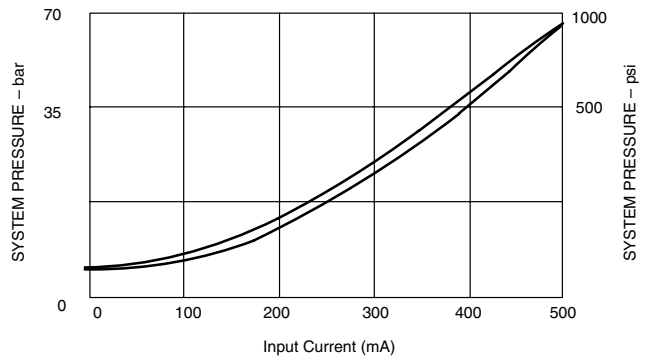

Pressure vs System Flow

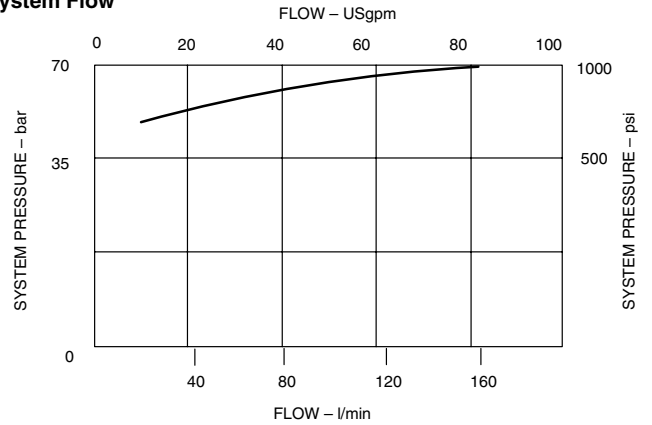
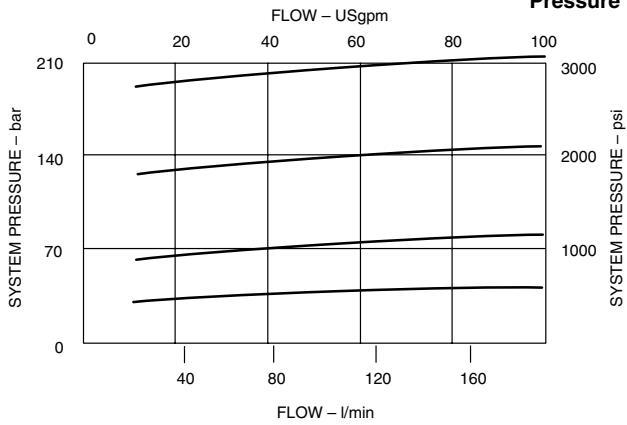

Minimum Pressure vs System Flow

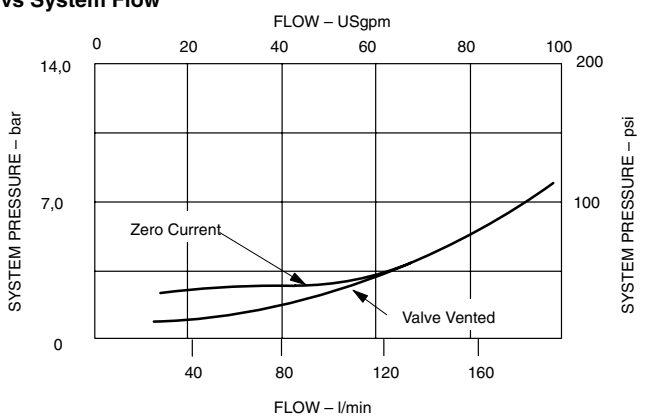
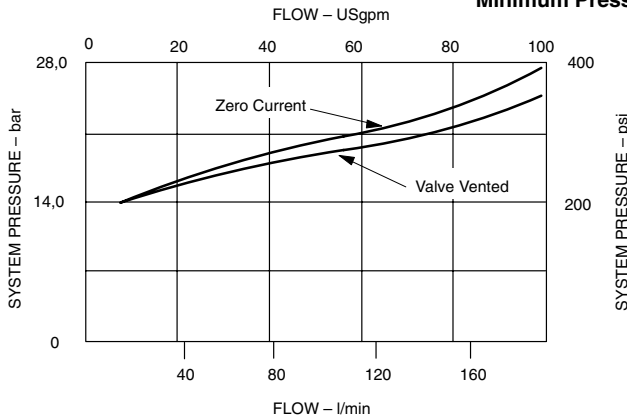

Series Model CGE Remote/Electrically Modulated Controls

Installation Dimensions

CGE-02

mm (inch)

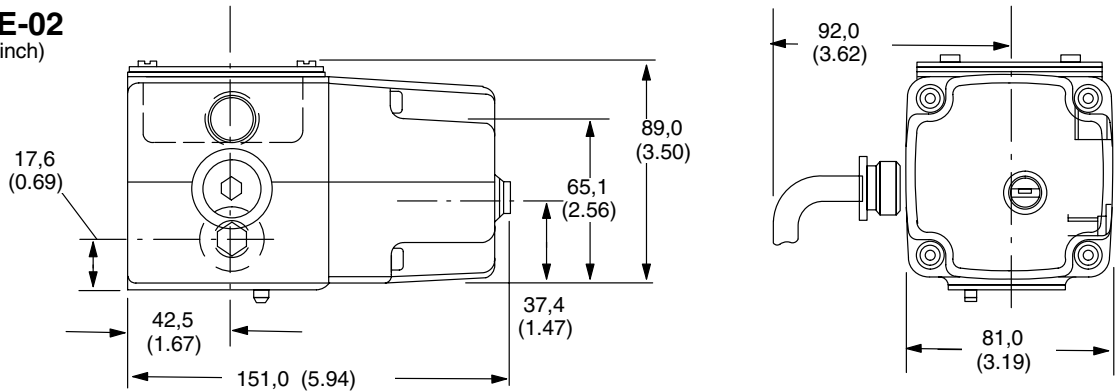

CGE-06/10-**-2*

mm (inch)

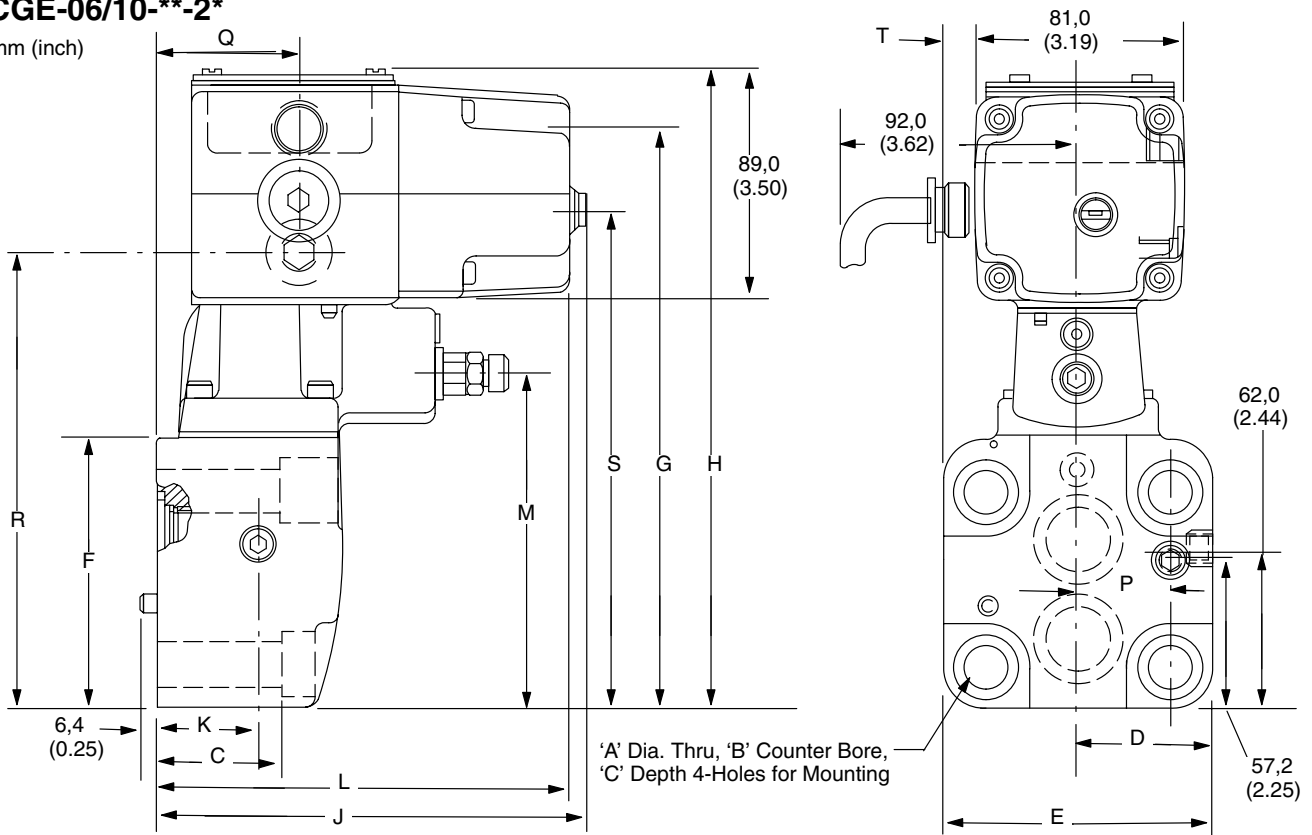

Model	A	B	C	D	E	F	G	H	J	K	L	M	N
CGE-06	16,6 (0.65)	24,6 (0.96)	47,8 (1.88)	53,4 (2.10)	106,4 (4.19)	103,1 (4.06)	220,5 (8.68)	244,4 (9.62)	165,0 (6.50)	38,9 (1.53)	158,6 (6.25)	127,0 (5.00)	71,4 (2.81)
CGE-10	19,8 (0.78)	29,3 (1.15)	63,5 (2.50)	66,8 (2.63)	133,4 (5.25)	109,5 (4.31)	231,7 (9.12)	255,5 (10.06)	170,5 (6.71)	42,9 (1.69)	164,1 (6.46)	138,2 (5.44)	85,9 (3.38)

P	Q	R	S	T	Weight	
					kg	lbs.
35,1 (1.38)	54,1 (2.13)	173,0 (6.81)	192,8 (7.59)	13,3 (0.53)	10	22
46,0 (1.81)	59,6 (2.35)	184,2 (7.25)	204,2 (8.04)	26,9 (1.06)	13	29

Series CGR-02 Remote Controls

Model Code

(F3) - CGR - 02 - C - (K) - 30

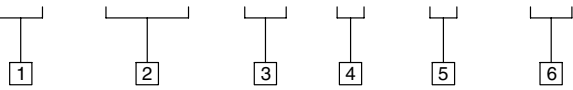

1 Seals

F3 – For mineral oil and fire resistant fluids

Blank – Omit if not required

2 Model Series

C – Relief valve

G – Subplate mounted

R – Remote control

3 Valve Size

02 – 6,35 mm (1/4 in) nominal size

4 Maximum Adjustable Pressure

B – 70 bar (1000 psi)

C – 140 bar (2000 psi)

F – 210 bar (3000 psi)

5 Adjusting Knob

K – Optional adjusting knob installed

Blank – Omit if not required

6 Design Number

Subject to change. Installation dimensions same for designs 30 through 39.

General Information

Typical application is as a remote control device for balanced piston type relief valves. The CGR-02 is not intended for use as a relief valve by itself. The valve is normally used to provide adjustment of system pressure from a convenient or remote location.

Pressure Range

The available pressure ranges for this valve are from 4,5 to 70 bar (65 to 1000 psi), from 4,5 to 140 bar (65 to 2000 psi), and from 4,5 to 210 bar (65 to 3000 psi). Therefore, the main system relief valve being controlled by the CGR-02 should be selected according to the maximum pressure required in the system. Check the model code for the main system relief valve.

Pressure Adjustment

Pressure can be adjusted by loosening a jam nut and turning an adjustment screw or optional adjustment knob. Turning clockwise increases pressure, and turning counterclockwise decreases pressure. The maximum pressure that can be attained by turning the adjusting screw is set at the factory to the value specified in the model code.

Graphical Symbol

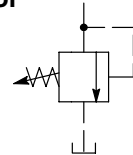

Ratings

The CGR-02 is rated for a maximum pressure of 210 bar (3000 psi). The following table lists minimum pressures attainable when the CGR-02 is used with five sizes of system relief valves at various system flows.

Model	Flow l/min (USgpm) Through Main System Relief Valve								
	19 (5)	38 (10)	78 (20)	170 (45)	284 (75)	379 (100)	568 (150)	758 (200)	947 (250)
	Minimum Pressure bar (psi)								
CS*-03*-50	4,7 (68)	5,0 (73)	5,9 (86)	9,5 (138)	—	—	—	—	—
CS*-03*-V-50	7,4 (108)	8,4 (122)	10,0 (145)	12,8 (186)	—	—	—	—	—
C**-06*-50	4,7 (68)	5,0 (73)	5,9 (86)	9,5 (138)	—	—	—	—	—
C**-06*-V-50	7,4 (108)	8,4 (122)	10,0 (145)	12,8 (186)	—	—	—	—	—
C**-10*-30	—	4,8 (69)	4,9 (71)	5,5 (80)	7,6 (110)	12,0 (174)	—	—	—
C**-10*-B-30	—	10,1 (146)	10,7 (155)	11,9 (172)	12,6 (182)	13,5 (196)	—	—	—
CF-16*-10	—	3,6 (52)	3,9 (56)	4,3 (62)	4,6 (66)	4,7 (68)	4,8 (70)	—	—
CF-16*-V-10	—	13,2 (192)	14,1 (204)	15,5 (225)	16,8 (244)	17,1 (248)	17,6 (255)	—	—
CF-24*-10	—	—	—	15,5 (225)	18,6 (270)	22,1 (320)	31,0 (450)	40,7 (590)	48,3 (700)
CF-24*-V-10	—	—	—	51,7 (750)	56,6 (820)	59,3 (860)	61,4 (890)	62,4 (905)	63,1 (915)

Series CGR-02 Remote Controls

Installation Dimensions

mm (inch)

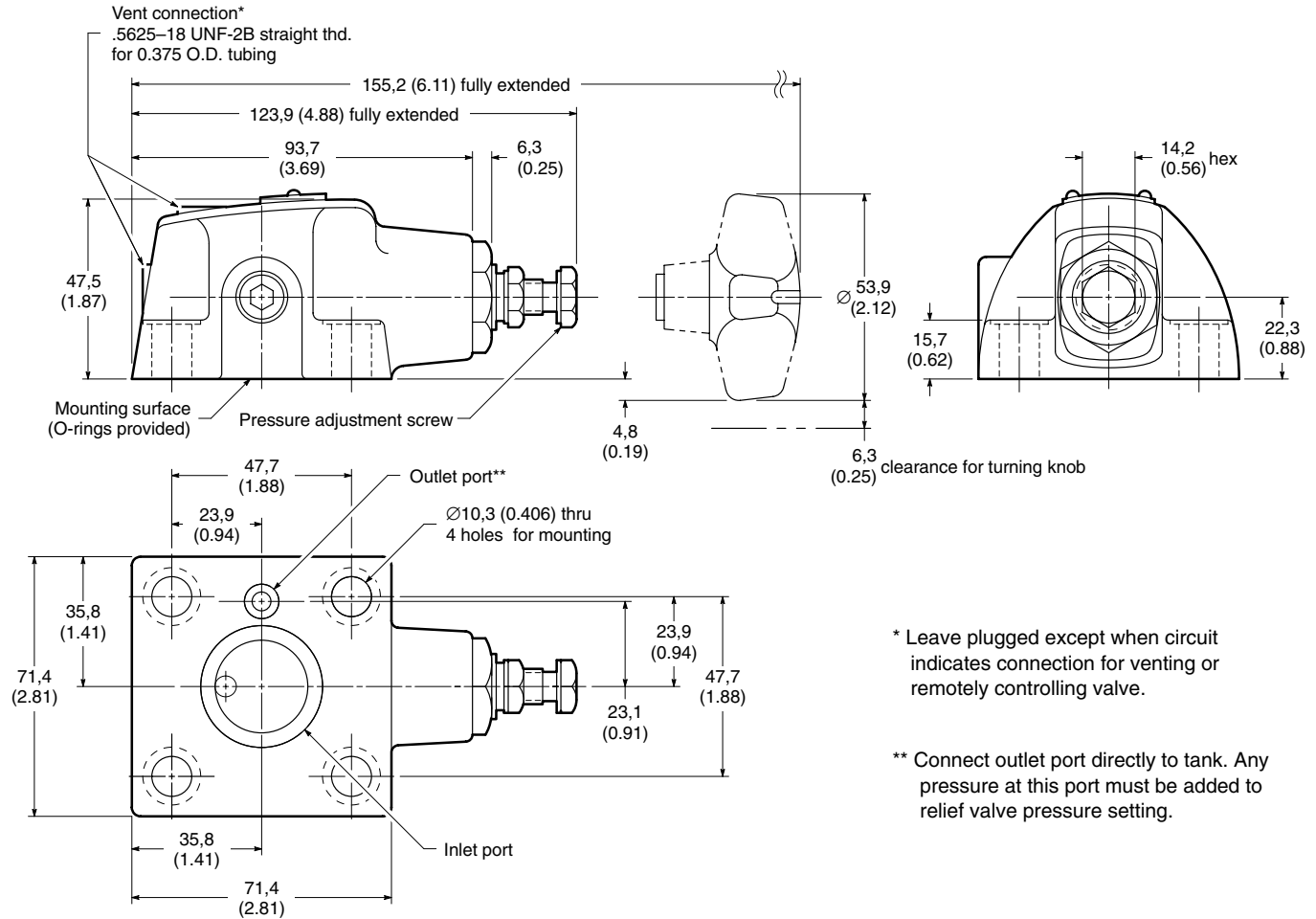

* Leave plugged except when circuit indicates connection for venting or remotely controlling valve.

** Connect outlet port directly to tank. Any pressure at this port must be added to relief valve pressure setting.

Mounting Pad

mm (inch)

The pad must be flat within 0,013 mm (0.0005 in) and smooth within 1,6 µm (63 microinch).

Mounting bolt torque (³/₈-16 screws) is 3,4 Nm (30 lb. ft.). Mounting bolts should be SAE grade 7 or better.

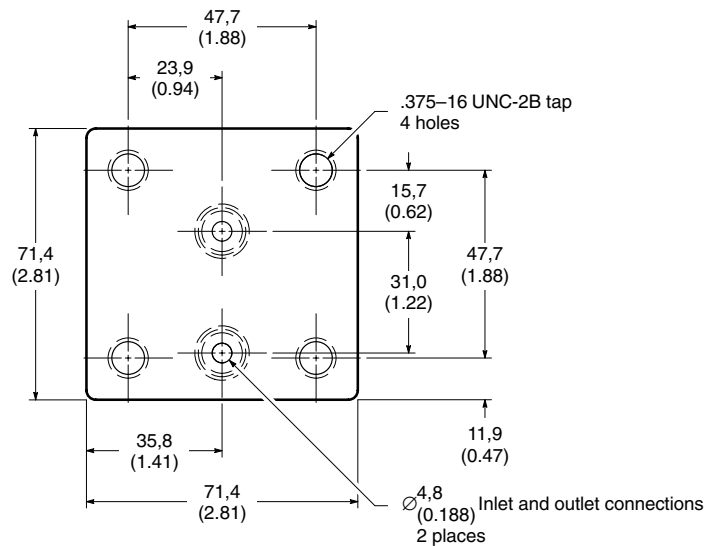

Series C-175 Remote Control/Relief Valves

Model Code

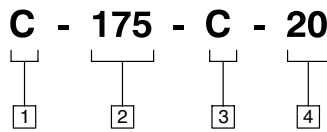

1 Model Series

C – Relief valve

2 Size

175 – 44,45 mm (1.75 in) diameter body

3 Pressure Range

B – 5 to 70 bar (75 to 1000 psi)

C – 35 to 140 bar (500 to 2000 psi)

F – 100 to 210 bar (1500 to 3000 psi)

4 Design Number

Subject to change. Installation dimensions same for designs 20 through 29.

General Information

The C-175 is suitable for applications requiring an adjustable, small capacity, direct action, spring-loaded type pressure relief valve or pressure regulating valve. It can also be applied as a remote control valve for pilot operation of balanced piston type relief valves. The C-175 is designed to be panel mounted.

Pressure Adjustment

Pressure can be adjusted by loosening a jam nut and turning the pressure adjustment knob. Turning clockwise increases pressure, and turning counterclockwise decreases pressure.

Ratings

The C-175 remote control for relief valves is rated for a maximum pressure of 210 bar (3000 psi) and a maximum flow capacity of 11,3 l/min (3 USgpm).

Graphical Symbol

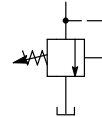

Series C-175 Remote Control/Relief Valves

Installation Dimensions

mm (inch)

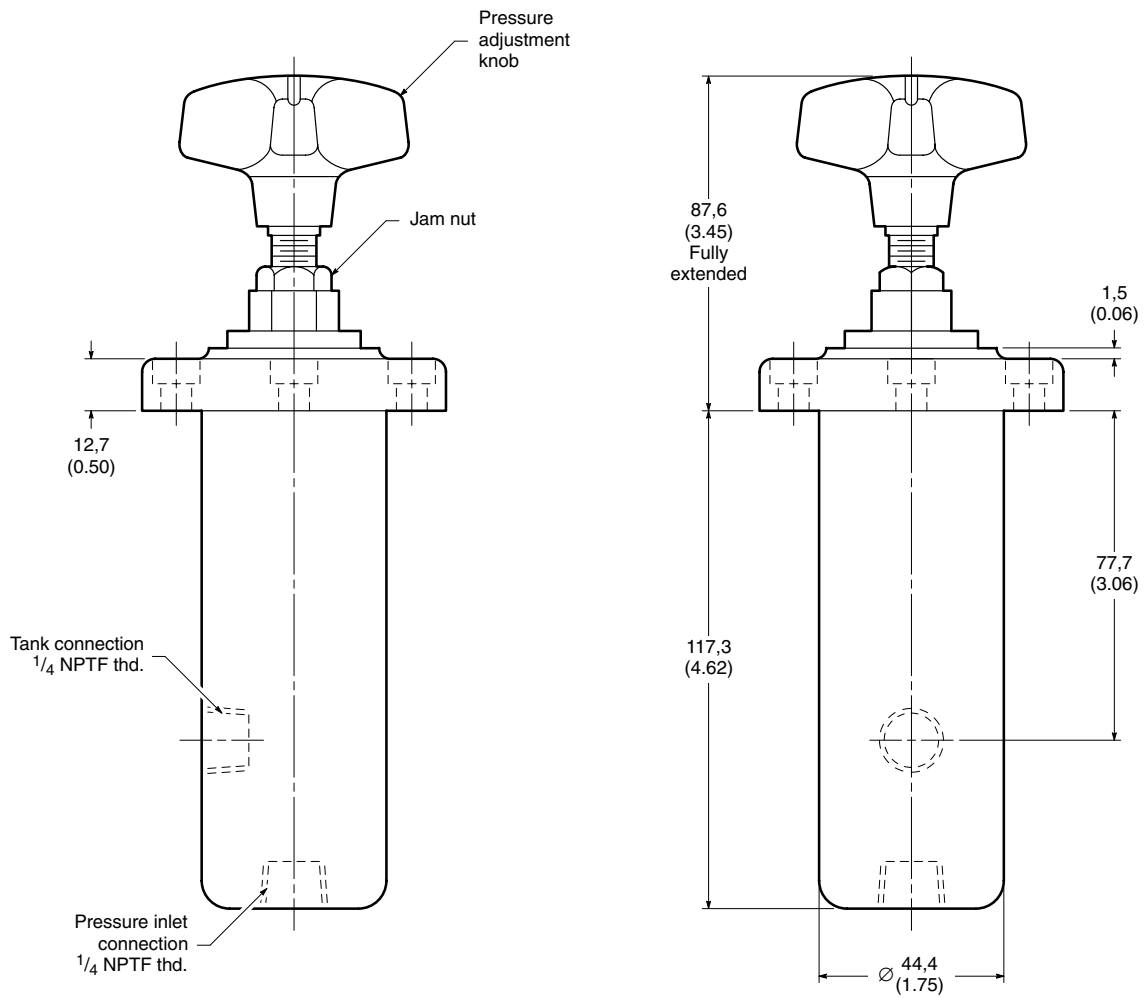
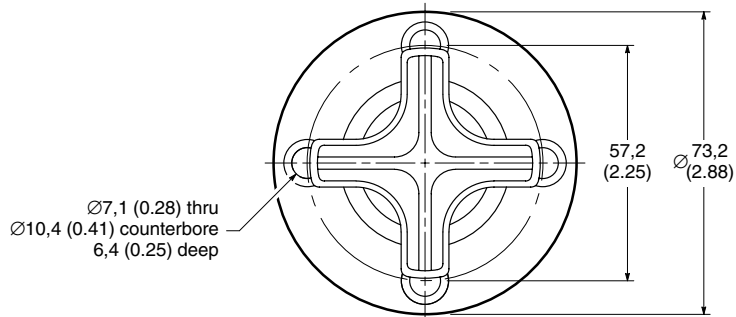

Series CG-03 Relief Valves

Model Code

(F3) - CG - 03 - C (V) - 10 - (S81)

┌───┐
┌───┐
┌───┐
┌───┐
┌───┐
┌───┐
┌───┐

└───┘
└───┘
└───┘
└───┘
└───┘
└───┘
└───┘

1
2
3
4
5
6
7

1 Seals

F3 – For mineral oil and fire resistant fluids

Blank – Omit if not required

2 Model Series

C – Relief valve

G – Subplate mounted

3 Valve Size

03 – 9,525 mm (³/₈ in) nominal size

4 Pressure Range

B – 5 to 70 bar (75 to 1000 psi)

C – 35 to 140 bar (500 to 2000 psi)

F – 100 to 210 bar (1500 to 3000 psi)

5 High Vent Spring

V – Optional high vent spring installed

Blank – Omit if not required

6 Design Number

Subject to change. Installation dimensions same for designs 10 through 19.

7 Special Feature Suffix

S81 – Optional handwheel control installed

General Information

Series CG-03 valves utilize balanced piston type construction. They are designed for applications requiring an adjustable pressure relief valve to limit system pressure to a desired maximum.

Pressure Adjustment

Pressure is adjusted by loosening a jam nut and turning an adjustment screw or optional handwheel. Turning clockwise increases pressure, and turning counterclockwise decreases pressure.

Graphical Symbols

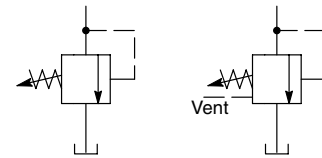

Pressure Range

The available pressure ranges for this valve are from 5 to 70 bar (75 to 1000 psi), from 35 to 140 bar (500 to 2000 psi), and from 100 to 210 bar (1500 to 3000 psi). Select an appropriate pressure range that will prevent excessively high working pressures from being imposed on the pump and other equipment.

Tank Connection

If tank line back pressure exceeds system pressure by 7 bar (100 psi), a malfunction may occur. Pressure in the tank line is additive to the pressure setting. Contact your Vickers representative for alternatives.

Ratings

The CG-03 is rated for a maximum pressure of 210 bar (3000 psi). Rated capacity is 0 to 30 l/min (0 to 8 USgpm). The following table lists approximate minimum venting pressures for the three available pressure ranges of the CG-03 with and without high vent springs.

Model	Pressure Range bar (psi)	Percentage of Maximum Rated Capacity			
		25%	50%	75%	100%
		Minimum Venting Pressure bar (psi)			
CG-03-B-10	5 to 70	25	27	28	32
CG-03-BV-10	(75 to 1000)	74	75	78	81
CG-03-C-10	35 to 140	25	27	28	32
CG-03-CV-10	(500 to 2000)	74	75	78	81
CG-03-F-10	100 to 210	25	27	28	32
CG-03-FV-10	(1500 to 3000)	74	75	78	81

Series CG-03 Relief Valves

Installation Dimensions

mm (inch)

Note

* Use vent connection only when circuit indicates a connection for venting relief valve.

** Not to exceed 7 bar (100 psi).

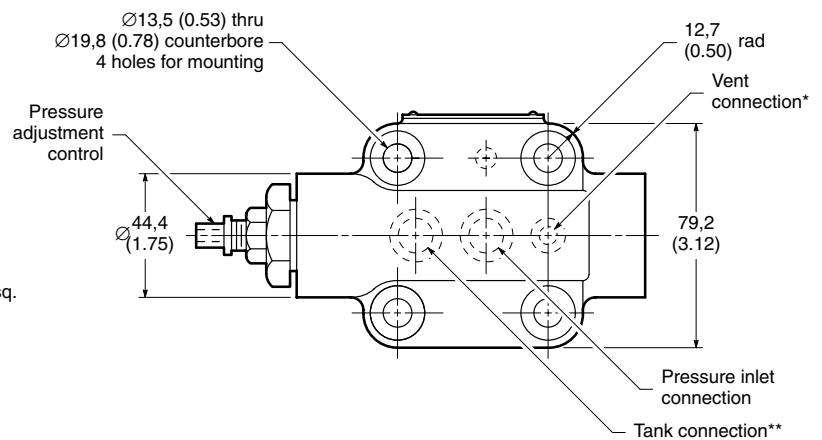
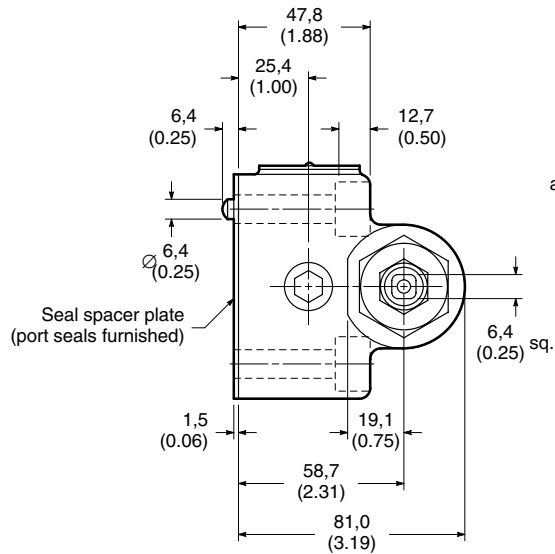
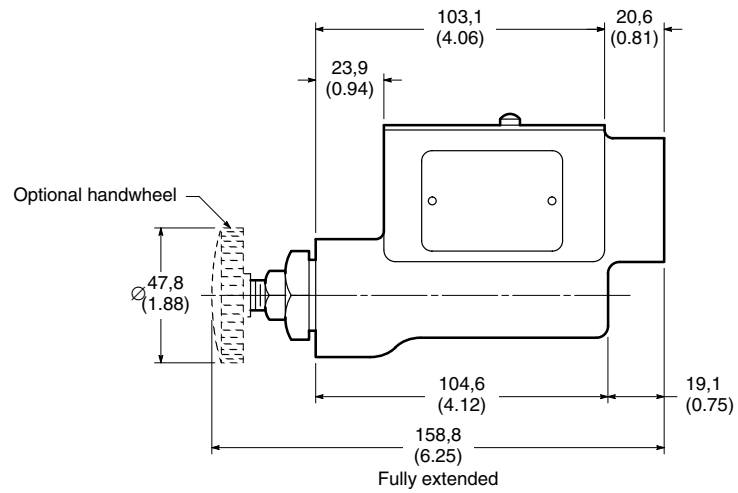

Mounting Subplates

mm (inch)

When a subplate is not used, a machined pad (shaded area) must be provided for mounting. The pad must be flat within 0,013 mm (0.0005 in) and smooth within 1,6 μm (63 microinch).

If mounting bolts are provided by the customer, they should be SAE grade 7 or better.

Subplates and Bolt Kits

Valves, subplates, and mounting bolts must be ordered separately.

Example:

- (1) CG-03-B-10 valve
- (1) CGM-10S-03-10 subplate
- (1) BKCG03602 bolt kit (assembly number 255602, consisting of four bolts, 1/2-13 x 2.00")

CGM-10S-03-10

(Straight thread connections)

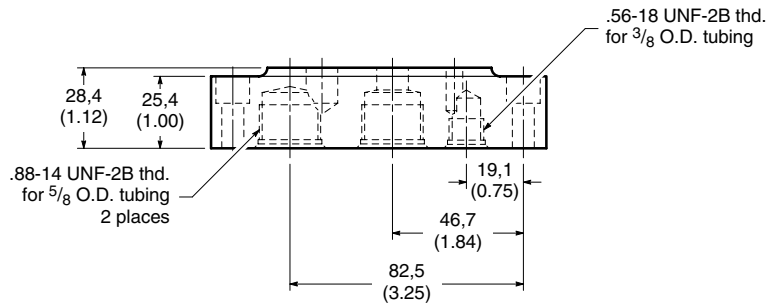
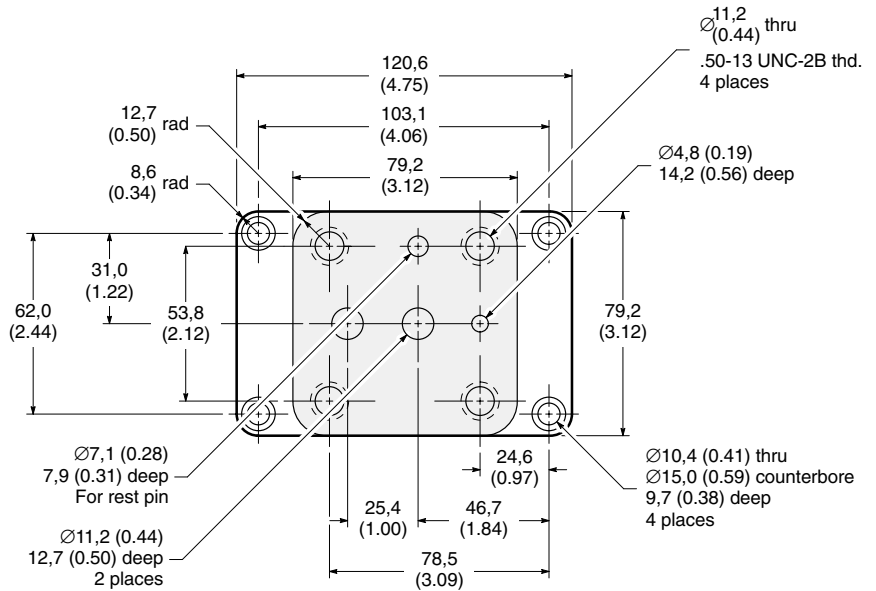

CGMT-03-10

(Pipe thread connections.* All other dimensions same as CGM-10S-03-10.)

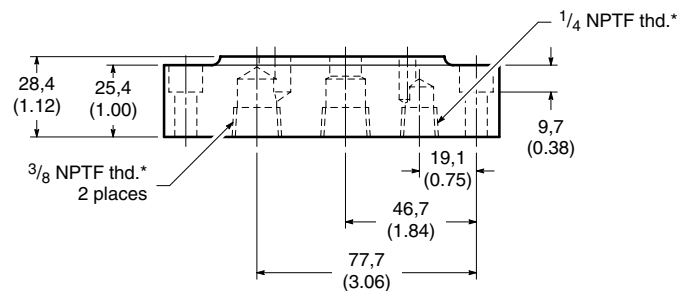

*Not recommended

Series C*-03/06/10 Relief/Sequence Valves

Model Code

C S - (H) 06 - C (V) (Y) - 50

1 Valve Type

C – Relief valve

2 Connections

S – SAE straight thread
T – NPTF thread* (not available in 03 size valve)

*Not recommended

3 High-flow Designation

H – High-flow valve (available in CS models only)
Blank – Omit if not required

4 Valve Size

03 – .8750-14 UNF-2B straight thread (0.625 tubing)
06 – 1.0625-12 UN-2B straight thread (0.750 tubing) or 3/4" pipe
10 – 1.6250-12 UN-2B straight thread (1.250 tubing) or 1 1/4" pipe

5 Pressure Range

B – 8,5 to 70 bar (125 to 1000 psi)
C – 35 to 140 bar (500 to 2000 psi)
F – 100 to 210 bar (1500 to 3000 psi)

6 High Vent Spring

V – Optional high vent spring installed (required in high-flow models)
Blank – Omit if not required

7 Sequence Valve Designation

Y – Configured as sequence valve (not available in 03 size valve)
Blank – Omit for relief valve

8 Design Number

5* – For 03 and 06 size valves
3* – For 10 size valve

Subject to change. Installation dimensions same for designs 30 through 39 and for designs 50 through 59.

General Information

The series C*-03/06/10 valve can be ordered as either a pressure relief valve or a sequence valve.

Inlet and outlet pressure connections can be used interchangeably when the valve is mounted in the pressure line. The valve may also be teed off the pressure line with one of the inlet pressure connections plugged.

Minimum venting pressure (see curves on page 18) designates the pressure at which the valve operates (regardless of adjustment) when the vent connection is open to tank. This action is sometimes required during a part of a cycle. Use only when indicated by circuit.

Relief Valve Configuration

The C*-03/06/10 is designed for use in applications requiring an adjustable pressure relief or regulating valve to limit the pressure in a hydraulic circuit to a desired maximum.

In addition to conventional relief valve operation, two other functional modes can be used: 1) system pressure can be limited to the valve's relatively low venting pressure by directing flow from the vent connection to tank; 2) system pressure can be remotely controlled by directing flow from the vent connection to a remote control pressure relief valve such as the C-175 or CGR-02.

The pressure setting of the relief valve selected should be approximately 10 to 14 bar (150 to 200 psi) above actual system working pressure. A higher setting could waste power and put unnecessary loads on the pump and other system components.

High-Flow Designation

A high vent spring must be included in high-flow models of the C*-06 and C*-10. The high-flow option is not available for the CS-03.

Tank Connection

Flow from the T port should be piped directly to the tank to minimize back pressure. Any pressure in the tank line is additive to the pressure setting.

If tank line back pressure exceeds system pressure by 7 bar (100 psi), a malfunction may occur. Contact your Vickers representative for alternatives.

Sequence Valve Configuration

Type "Y" (pressure sequence) versions of the C*-03/06/10 valve are designed for applications that require an adjustable pressure operated valve to control the sequence of flow to another branch of a circuit.

Sequence Operation

When pressure at the inlet port exceeds the valve setting, flow from the pressure inlet is directed to the secondary outlet port. The secondary outlet receives full pressure, and the valve acts as a tee in the line. Reverse free flow connections (secondary outlet to primary inlet) are not provided in this design.

Select an appropriate pressure range for the valve so that the pump and other equipment are not subjected to excessively high working pressures.

These sequence valves perform the same hydraulic circuit function as RS-06 and RS-10 sequence valves. The C*-03/06/10 models, however, are capable of functioning at higher flows and faster sequencing with less pressure overshoot.

Pressure Range

The available pressure ranges for this valve are from 8,5 to 70 bar (125 to 1000 psi), from 35 to 140 bar (500 to 2000 psi), and from 100 to 210 bar (1500 to 3000 psi). Select the appropriate pressure range that will prevent excessively high working pressures from being imposed on the pump and other equipment.

Pressure Adjustment

Pressure can be adjusted by loosening a jam nut and turning an adjustment knob. Turning clockwise increases pressure, and turning counterclockwise decreases pressure.

Ratings

The C*-03/06/10 is rated for a maximum pressure of 210 bar (3000 psi). The following table lists pressure ranges and rated flows for the CS-03, C*-06, and C*-10 standard and high-flow models.

Model	Pressure Range bar (psi)	Rated Flow l/min (USgpm)	
		Standard	High-Flow
CS-03-B*-50	8,5 to 70 (125 to 1000)	175 (45)	—
CS-03-C*-50	35 to 140 (500 to 2000)		
CS-03-F*-50	10 to 210 (1500 to 3000)		
CS/T-06-B*-50	8,5 to 70 (125 to 1000)	227 (60)	340 (90)
CS/T-06-C*-50	35 to 140 (500 to 2000)		
CS/T-06-F*-50	100 to 210 (1500 to 3000)		
CS/T-10-B*-30	8,5 to 70 (125 to 1000)	454 (120)	680 (180)
CS/T-10-C*-30	35 to 140 (500 to 2000)		
CS/T-10-F*-30	100 to 210 (1500 to 3000)		

Graphical Symbols

Relief Valves

Using Vent Connection

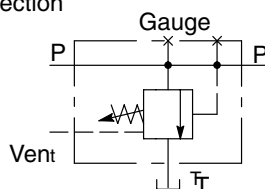
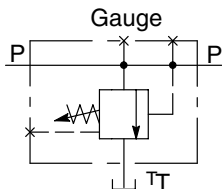

Sequence Valves

Using Vent Connection

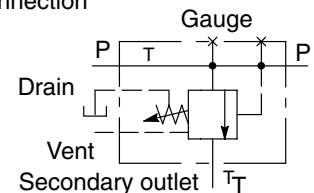
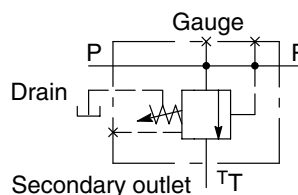

Series C*-03/06/10 Relief/Sequence Valves

Performance Curves

Nominal Override Characteristics

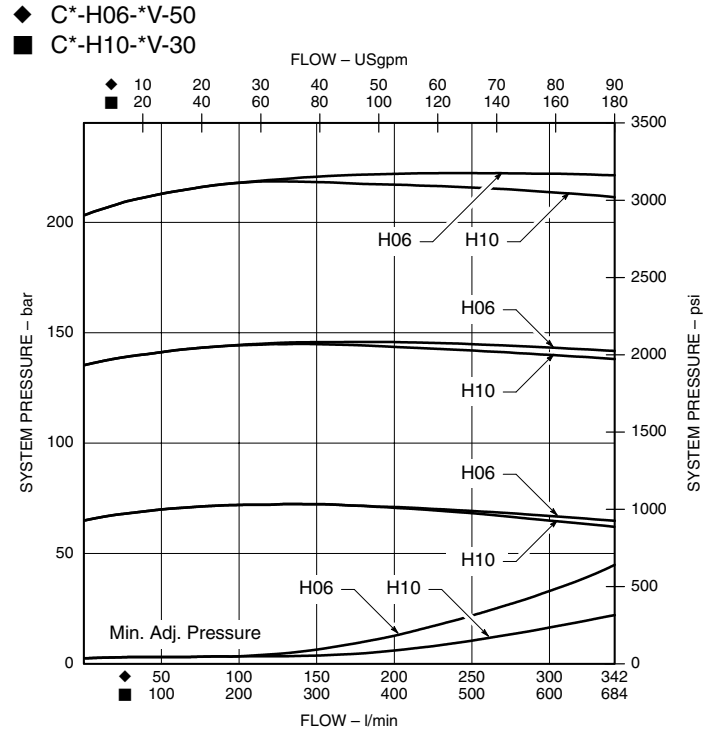
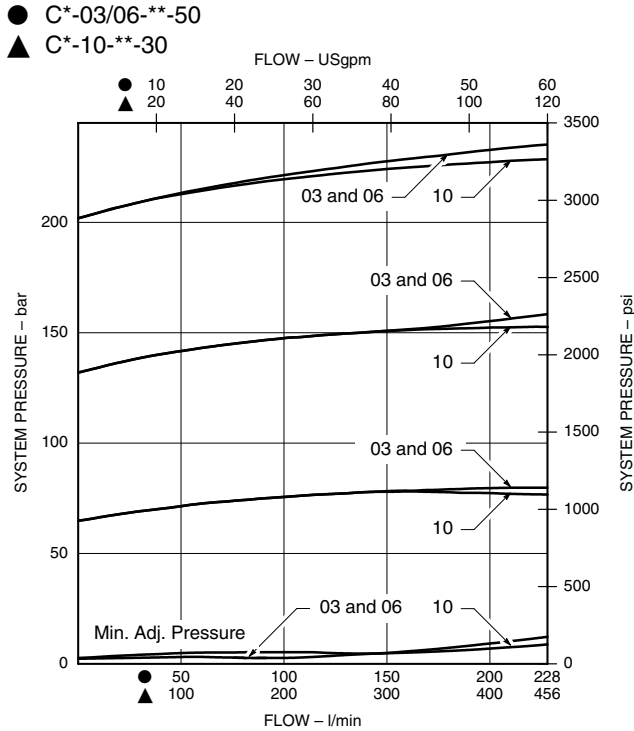

Vent Pressure Versus Flow

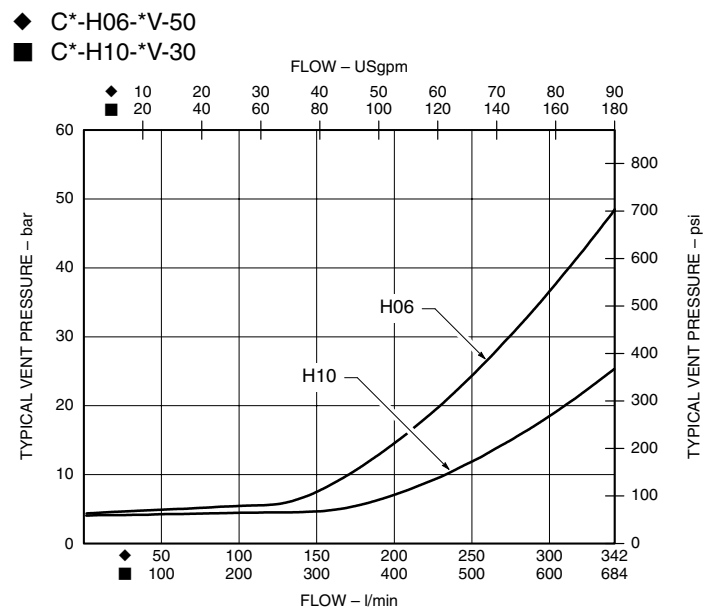
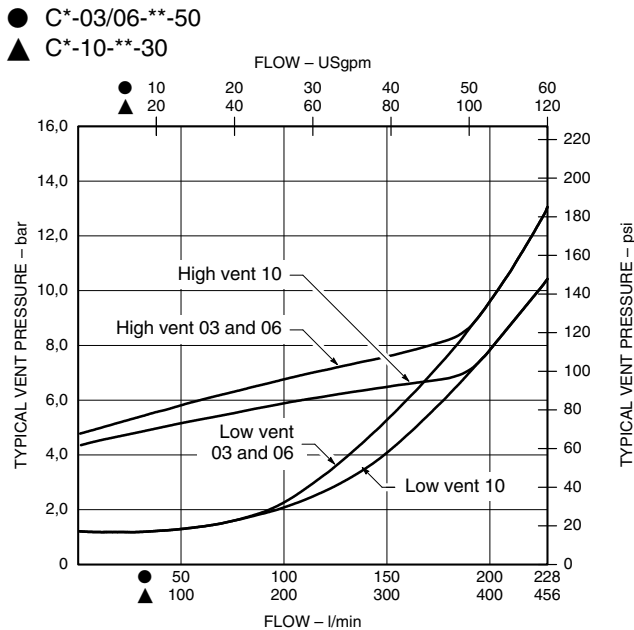

Installation Dimensions

mm (inch)

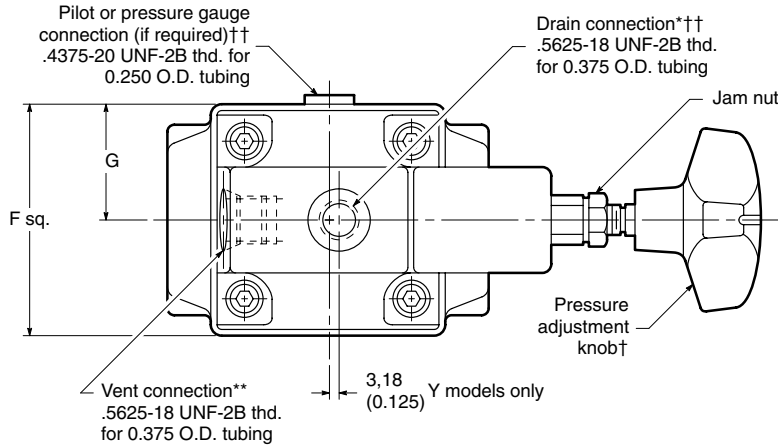

Notes

* Drain connection on Y models only. Not available in 03 size valve. Connect directly to tank. Pressure at drain port is additive to pressure setting.

** Leave plugged except when circuit indicates connection for venting or remotely controlling valve.

† Knob can be backed out beyond minimum pressure stop. Reposition knob (if desired) to any 90° increment by reinstalling cover.

†† Per SAE Standard J-514.

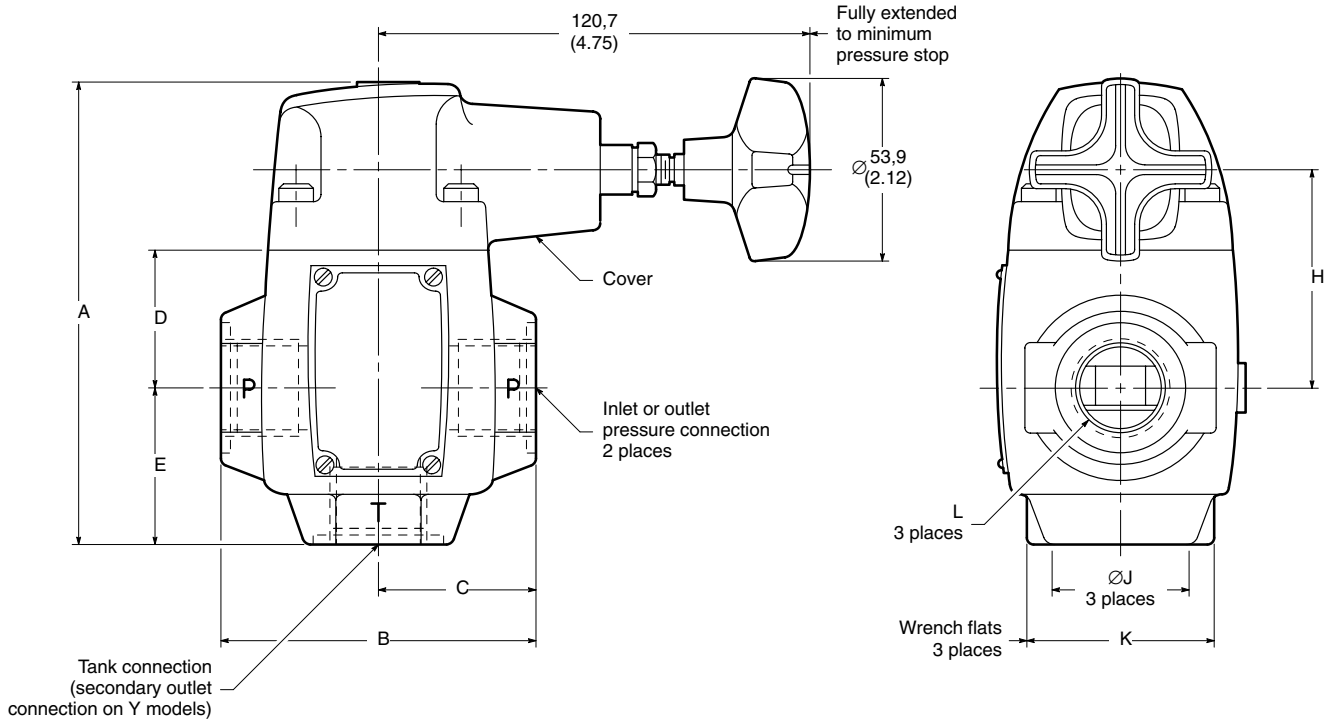

Model	A	B	C	D	E	F	G	H	J	K	L – System Connections	
											CS Models	CT Models††
CS-03	143,3 (5.64)	95,5 (3.76)	47,8 (1.88)	39,9 (1.57)	55,6 (2.19)	65,6 (2.58)	32,8 (1.29)	62,0 (2.45)	45,7 (1.80)	53,9 (2.12)	.875-14 UNF-2B thd. (0.625 O.D. tubing)	Not available in 03 size valve
CS-06 CT-06											1.0625-12 UN-2B thd. (0.750 O.D. tubing)	3/4 NPTF thd.††
CS-10	157,2 (6.18)	124,0 (4.88)	61,9 (2.44)	41,2 (1.62)	61,9 (2.44)	83,3 (3.28)	41,7 (1.64)	66,5 (2.62)	61,9 (2.44)	69,9 (2.75)	1.6250-12 UN-2B thd. (1.250 O.D. tubing)	1 1/4 NPTF thd.††

†† Not recommended

Series CG-06/10 Relief/Sequence Valves

Model Code

(F3) CG - (H) 06 - C (V) (Y) - 50

1 Seals

F3 – For mineral oil and fire resistant fluids
Blank – Omit if not required

2 Model Series

C – Relief valve
G – Subplate mounted

3 High-flow Designation

H – High-flow valve (available in relief valves only)
Blank – Omit if not required (and for sequence valves)

4 Valve Size

06 – 1.0625-12 UN-2B straight thread (0.750 tubing) or 3/4" pipe
10 – 1.6250-12 UN-2B straight thread (1.250 tubing) or 1 1/4" pipe

5 Pressure Range

B – 8,5 to 70 bar (125 to 1000 psi)
C – 35 to 140 bar (500 to 2000 psi)
F – 100 to 210 bar (1500 to 3000 psi)

6 High Vent Spring

V – Optional high vent spring installed (required in high-flow models)
Blank – Omit if not required

7 Sequence Valve Designation

Y – Configured as sequence valve
Blank – Omit for relief valve

8 Design Number

50 – For 06 size valve
30 – For 10 size valve

Subject to change. Installation dimensions same for designs 30 through 39 and for designs 50 through 59.

General Information

The series CG-06/10 valve is designed for manifold or subplate mounting and can be ordered as either a pressure relief valve or a sequence valve.

Minimum venting pressure (see curves on page 22) designates the pressure at which the valve operates (regardless of adjustment) when the vent connection is open to tank. This action is sometimes required during a part of a cycle. Use only when indicated by circuit.

Relief Valve Configuration

The CG-06/10 is designed for use in applications requiring an adjustable pressure relief or regulating valve to limit the pressure in a hydraulic circuit to a desired maximum.

In addition to conventional relief valve operation, two other functional modes can be used: 1) system pressure can be limited to the valve's relatively low venting pressure by directing flow from the vent connection to tank; 2) system pressure can be remotely controlled by directing flow from the vent connection to a remote control pressure relief valve such as the C-175 or CGR-02.

The pressure setting of the relief valve selected should be approximately 10 to 14 bar (150 to 200 psi) above actual system working pressure. A higher setting could waste power and put unnecessary loads on the pump and other system components.

High-Flow Designation

A high vent spring must be included in high-flow models of the CG-06 and CG-10.

Tank Connection

Flow from the T port should be piped directly to the tank to minimize back pressure. Any pressure in the tank line is additive to the pressure setting.

If tank line back pressure exceeds system pressure by 7 bar (100 psi), a malfunction may occur. Contact your Vickers representative for alternatives.

Sequence Valve Configuration

Type "Y" (pressure sequence) versions of the CG-06/10 valve are designed for applications that require an adjustable pressure operated valve to control the sequence of flow to another branch of a circuit.

Sequence Operation

When pressure at the inlet port exceeds the valve setting, flow from the pressure inlet is directed to the secondary outlet port. The secondary outlet receives full pressure. Reverse free flow connections (secondary outlet to primary inlet) are not provided in this design.

Select an appropriate pressure range for the valve so that the pump and other equipment are not subjected to excessively high working pressures.

These sequence valves perform the same hydraulic circuit function as RG-06 and RG-10 sequence valves. The CG-06/10 models, however, are capable of functioning at higher flows and faster sequencing with less pressure overshoot.

Drain Connection

The drain connection should be piped directly to the tank to minimize back pressure. Any pressure in the drain line is additive to the pressure setting.

Pressure Range

The available pressure ranges for this valve are from 8,5 to 70 bar (125 to 1000 psi), from 35 to 140 bar (500 to 2000 psi), and from 100 to 210 bar (1500 to 3000 psi). Select an appropriate pressure range for the valve so that the pump and other equipment are not subjected to excessively high working pressures.

Pressure Adjustment

Pressure can be adjusted by loosening a jam nut and turning an adjustment knob. Turning clockwise increases pressure, and turning counterclockwise decreases pressure.

Mounting Adapter Plates

Two relief valve mounting adapter plates (see page 26) are available to adapt current design relief valves to the -10 design mounting. The CGAM-06-20 adapts a CG-(H)06-*(V)-5* valve to a CG-06-*(V)-10 mounting. The CGAM-10-20 adapts a CG-(H)10-*(V)-3* valve to a CG-06-*(V)-10 mounting.

The following bolt kits are used with mounting adapter plates to mount CG-06/10 valves:

Valve	Bolt Kit
CG-(H)06-*(V)-5*	BKCGAM06608
CG-(H)10-*(V)-3*	BKCGAM10609†

† Holds only adapter plate to mounting pad or subplate. Separate bolt kit needed to mount relief valve to adapter plate.

Ratings

The CG-06/10 is rated for a maximum pressure of 210 bar (3000 psi). The following table lists pressure ranges and rated flows for the CG-06 and CG-10 standard and high-flow models.

Model	Pressure Range bar (psi)	Rated Flow l/min (USgpm)	
		Standard	High-Flow
CG-06-B*-50	8,5 to 70 (125 to 1000)	227 (60)	340 (90)
CG-06-C*-50	35 to 140 (500 to 2000)		
CG-06-F*-50	100 to 210 (1500 to 3000)		
CG-10-B*-30	8,5 to 70 (125 to 1000)	454 (120)	680 (180)
CG-10-C*-30	35 to 140 (500 to 2000)		
CG-10-F*-30	100 to 210 (1500 to 3000)		

Graphical Symbols

Relief Valves

Using Vent Connection

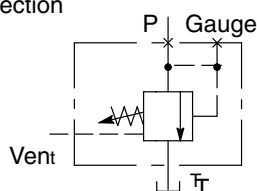
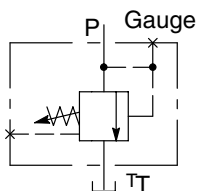

Sequence Valves

Using Vent Connection

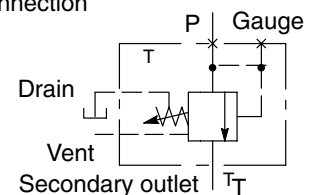
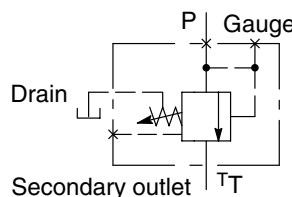

Series CG-06/10 Relief/Sequence Valves

Performance Curves

Nominal Override Characteristics

- CG-06-**-50
- ▲ CG-10-**-30

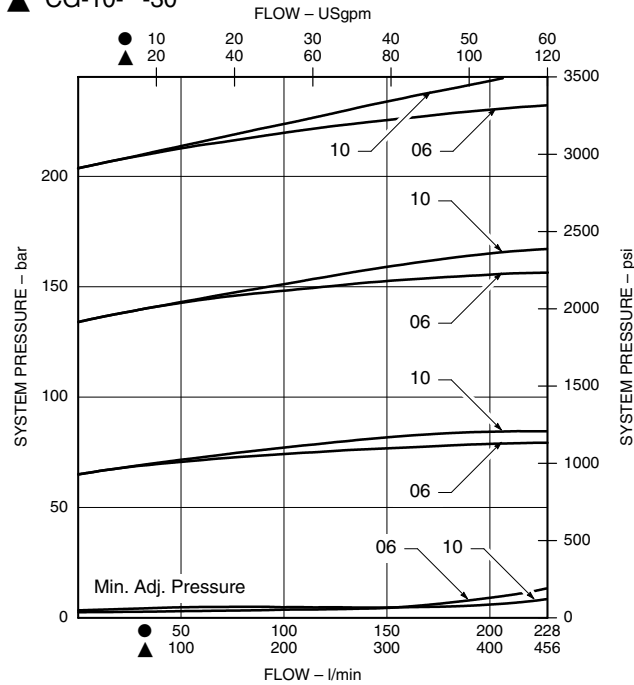

- ◆ CG-H06-*V-50
- CG-H10-*V-30

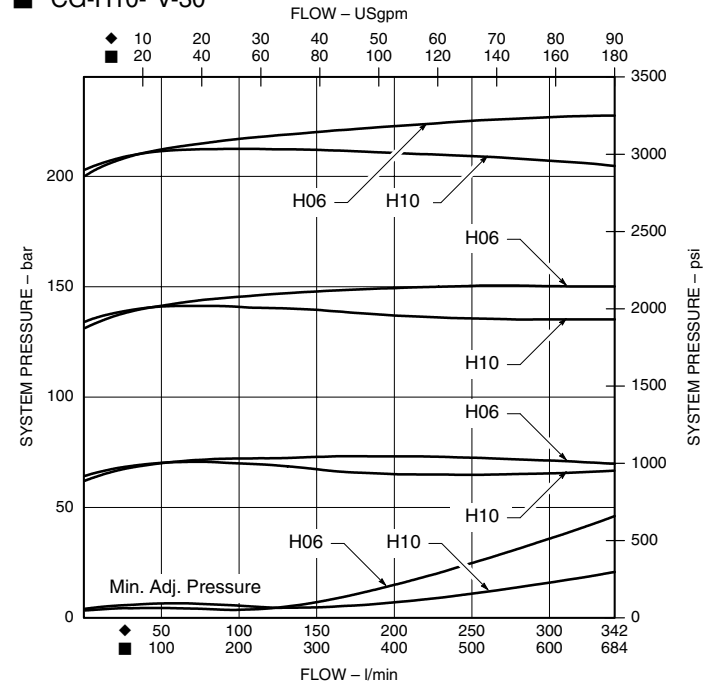

Vent Pressure Versus Flow

- CG-06-**-50
- ▲ CG-10-**-30

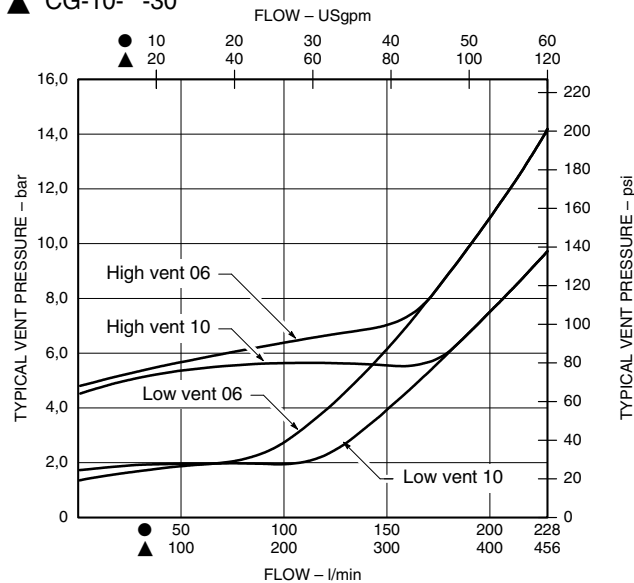

- ◆ CG-H06-*V-50
- CG-H10-*V-30

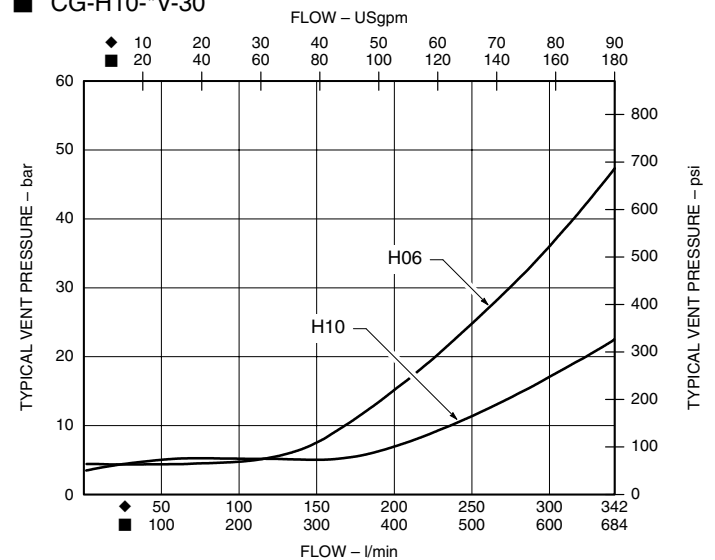

Installation Dimensions

mm (inch)

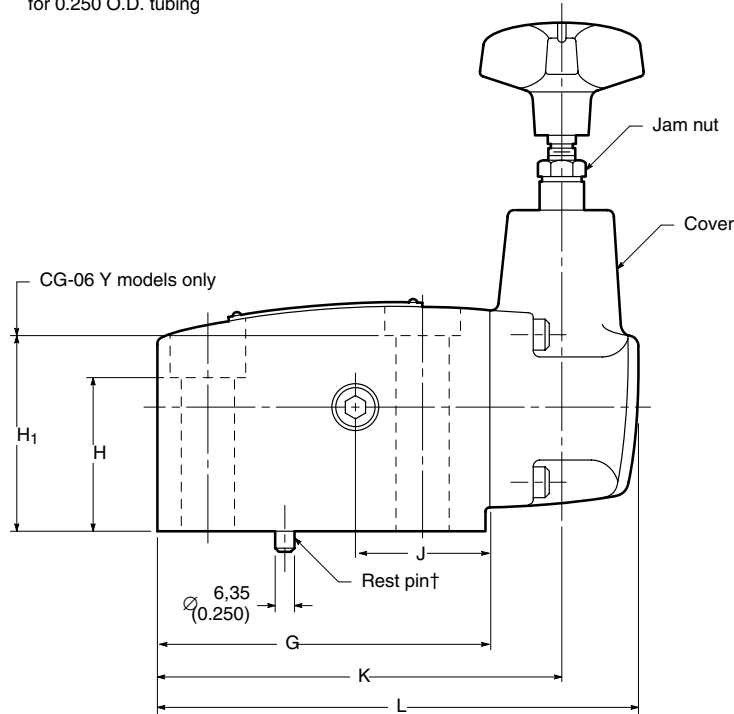
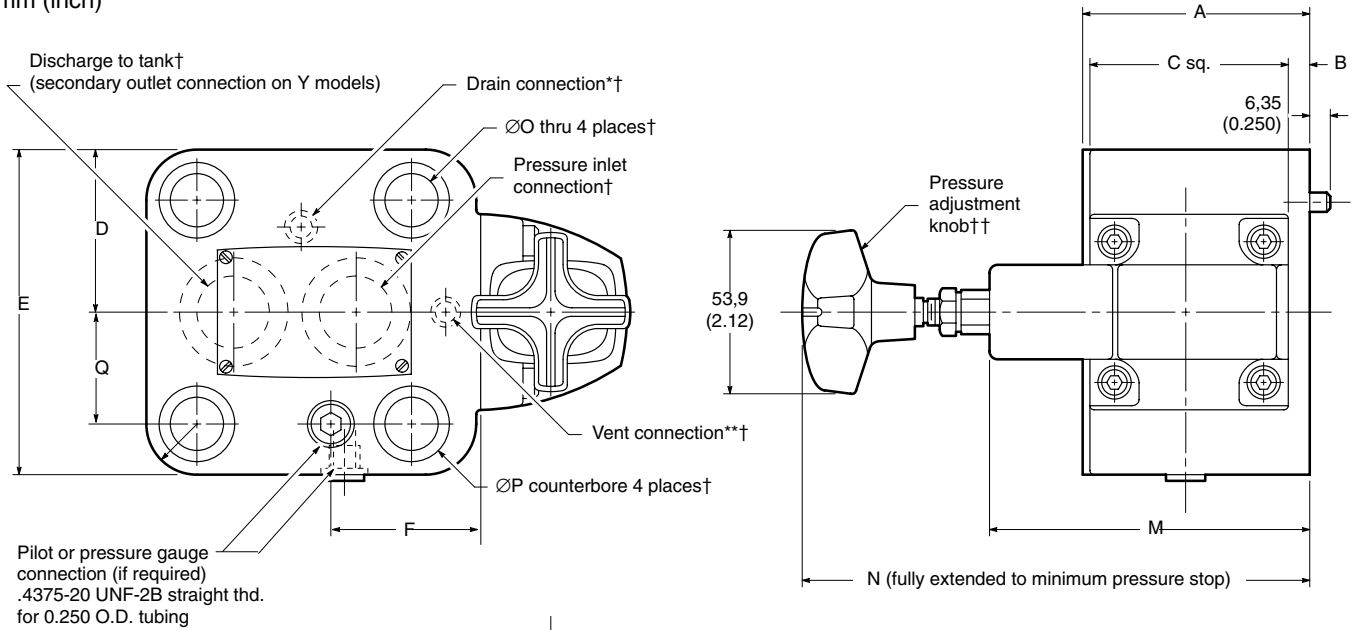

Note

* Drain connection on Y models only. Connect directly to tank. Pressure at drain port is additive to pressure setting.

** Leave plugged except when circuit indicates connection for venting or remotely controlling valve.

† See dimensions of applicable subplate (page 24) for location.

†† Knob can be backed out beyond minimum pressure stop. Reposition knob (if desired) 90° up or down from position shown by reinstalling cover (except on Y models).

Model	A	B	C	D	E	F	G	H	H ₁	J	K	L	M	N
CG-06	71,4 (2.81)	7,9 (0.31)	62,0 (2.44)	53,3 (2.10)	106,4 (4.19)	47,8 (1.88)	107,2 (4.22)	47,8 (1.88)	60,5 (2.38)	42,9 (1.69)	131,1 (5.16)	156,5 (6.16)	100,8 (3.97)	159,5 (6.28)
CG-10	85,9 (2.81)	2,3 (0.31)	81,0 (2.44)	66,8 (2.63)	133,4 (5.25)	55,6 (2.19)	116,1 (4.57)	63,5 (2.50)	N/A	50,8 (2.00)	141,5 (5.57)	164,6 (6.48)	104,7 (4.12)	163,6 (6.44)

Model	O	P	Q
CG-06	16,6 (0.65)	24,5 (0.96)	35,1 (1.38)
CG-10	19,8 (0.78)	29,3 (1.15)	46,0 (1.81)

Series CG-06/10 Relief/Sequence Valves

Subplates and Bolt Kits

Valves, subplates, and mounting bolts must be ordered separately.

Example:

- (1) CG-06-B-50 valve
- (1) CGM-06S-20 subplate
- (1) BKCG06604 bolt kit (consisting of four bolts, $\frac{5}{8}$ -11 x 2.75")

When a subplate is not used, a machined pad (shaded area) must be provided for mounting. The pad must be flat within 0,013 mm (0.0005 in) and smooth within 1,6 μ m (63 microinch).

If mounting bolts are provided by the customer, they should be SAE grade 7 or better.

The following bolt kits are used to mount CG-06/10 valves:

Valve	Bolt Kit
CG-(H)06-*(V)-5*	BKCG06604
CG-06-*(V)Y-5*	BKCG06605
CG-(H)10-*(V)-3*	BKCG10616
CG-10-*(V)Y-3*	BKCG10616

Mounting Subplates

mm (inch)

CGM-06S-20 (for $\frac{3}{4}$ " O.D. tubing)

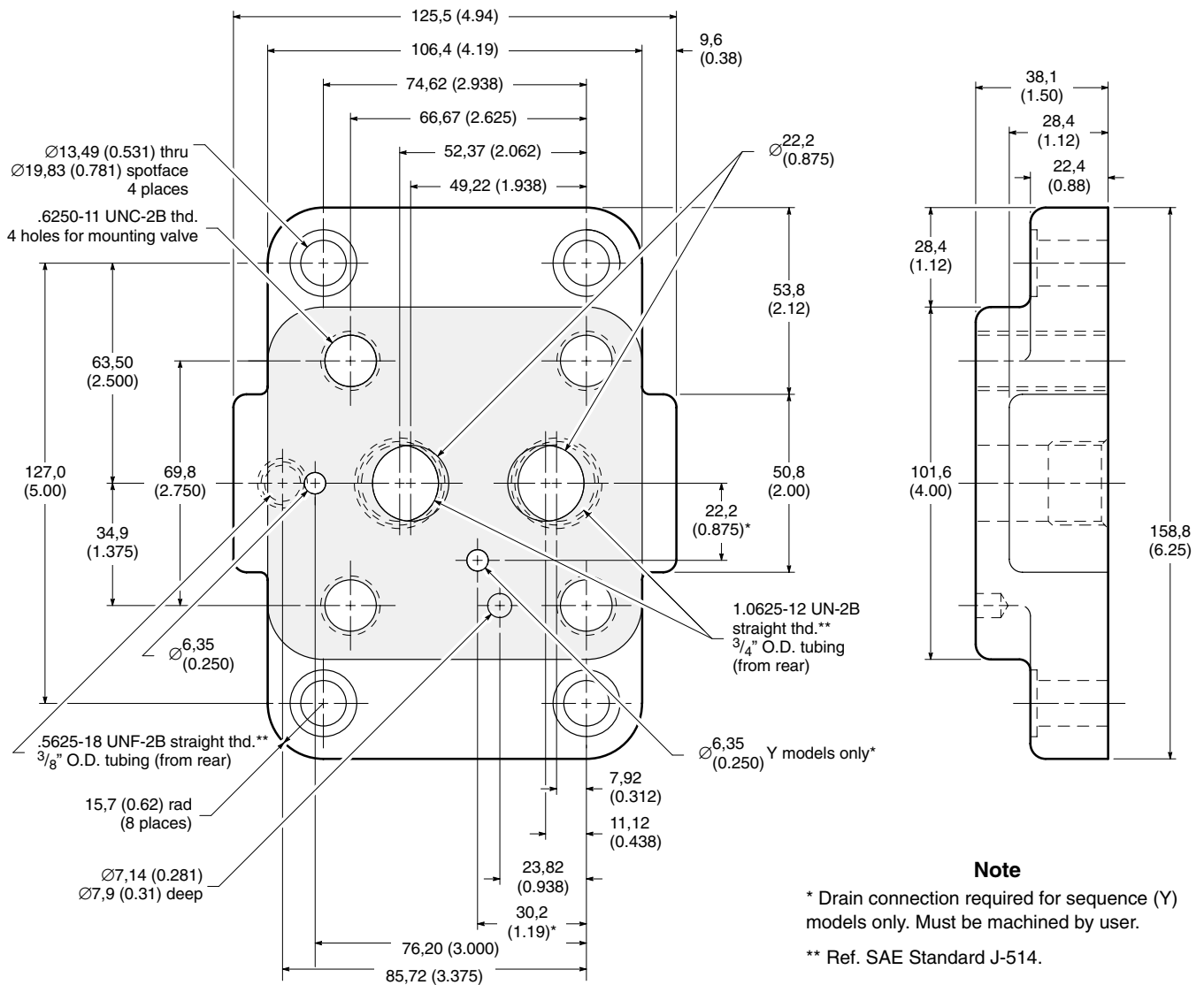

Note

* Drain connection required for sequence (Y) models only. Must be machined by user.

** Ref. SAE Standard J-514.

CGM-10S-20 (for 1 1/4" O.D. tubing)

mm (inch)

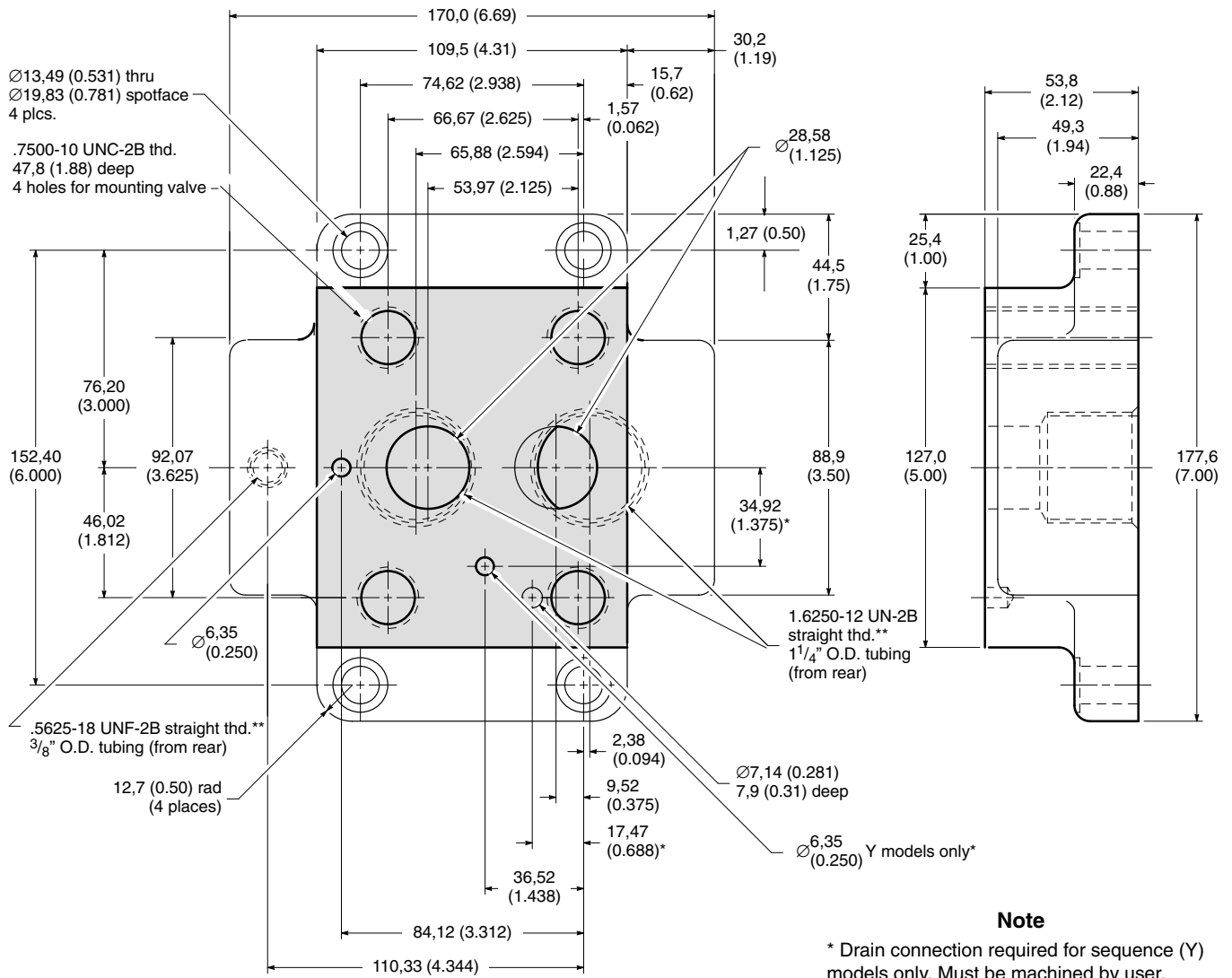

Note

* Drain connection required for sequence (Y) models only. Must be machined by user.

** Ref. SAE Standard J-514.

Series CGAM-06/10 Adapter Mounting Plates

Model Code

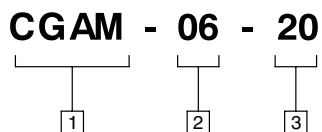

1 Model Series

C – Relief valve
G – Subplate mounted
A – Adapter
M – Mounting plate

2 Compatible Valve Size

06 – 1.0625-12 UN-2B straight thread
 (0.750 tubing) or $\frac{3}{4}$ " pipe
10 – 1.6250-12 UN-2B straight thread
 (1.250 tubing) or $1\frac{1}{4}$ " pipe

3 Design Number

Subject to change. Installation dimensions same for designs 20 through 29.

General Information

CGAM-06/10 adapter mounting plates are designed for adapting new, improved valves to the subplate or machined mounting pad used by a superseded valve.

Adapter Mounting Plate	Superseded Valve	New Valve
CGAM-06-20	CG-06-**-10	CG-06-**-20 and up
	CG5-06**-**-20	CG5-06**-**-30 and up
CGAM-10-20	CG-10-**-10	CG-10-**-20 and up
	CG5-10**-**-20	CG5-10**-**-30 and up

Mounting Bolts

Mounting bolts are not included with adapter plates and must be ordered separately.

Examples:

(1) CGAM-06-20 mounting adapter plate
 (1) BKCGAM06608 bolt kit (consisting of four bolts, $\frac{5}{8}$ -11 × 3.50")

(1) CGAM-10-20 mounting adapter plate
 (1) BKCGAM10609 bolt kit (consisting of four bolts, $\frac{3}{4}$ -10 × 2.50")

Mounting bolts for the CGAM-06-20 hold *both* the relief valve and the adapter plate to a mounting pad or subplate. Mounting bolts for the CGAM-10-20 hold *only* the adapter plate to a mounting pad or subplate. A separate bolt kit is needed to mount the relief valve to the adapter plate.

If mounting bolts are provided by the customer, they should be SAE grade 7 or better.

Installation Dimensions

mm (inch)

CGAM-06-20

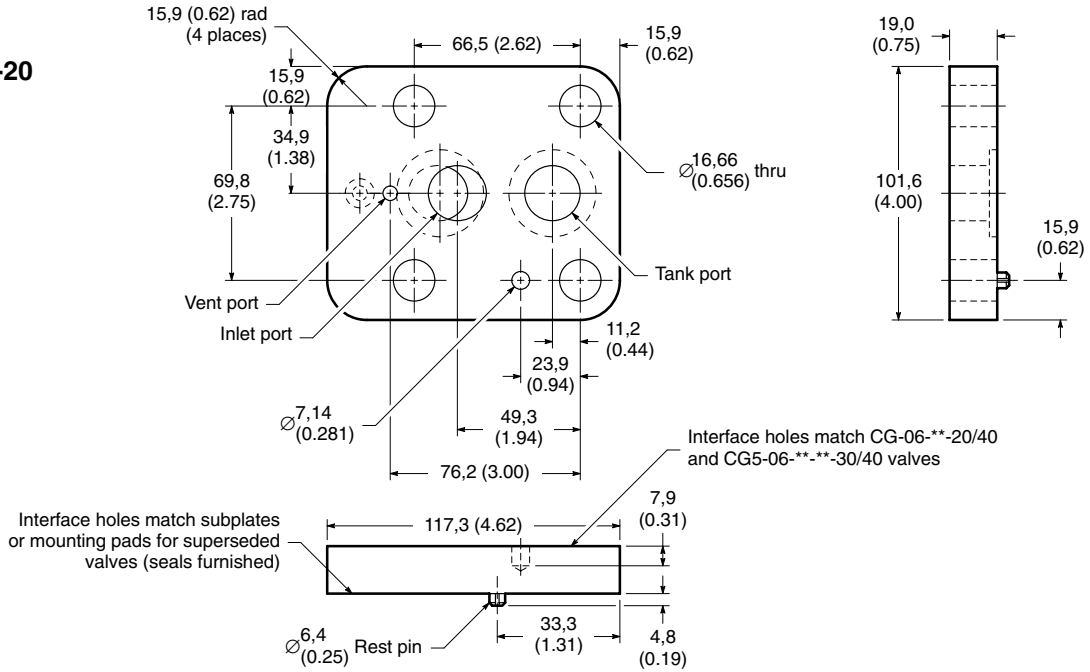

CGAM-10-20

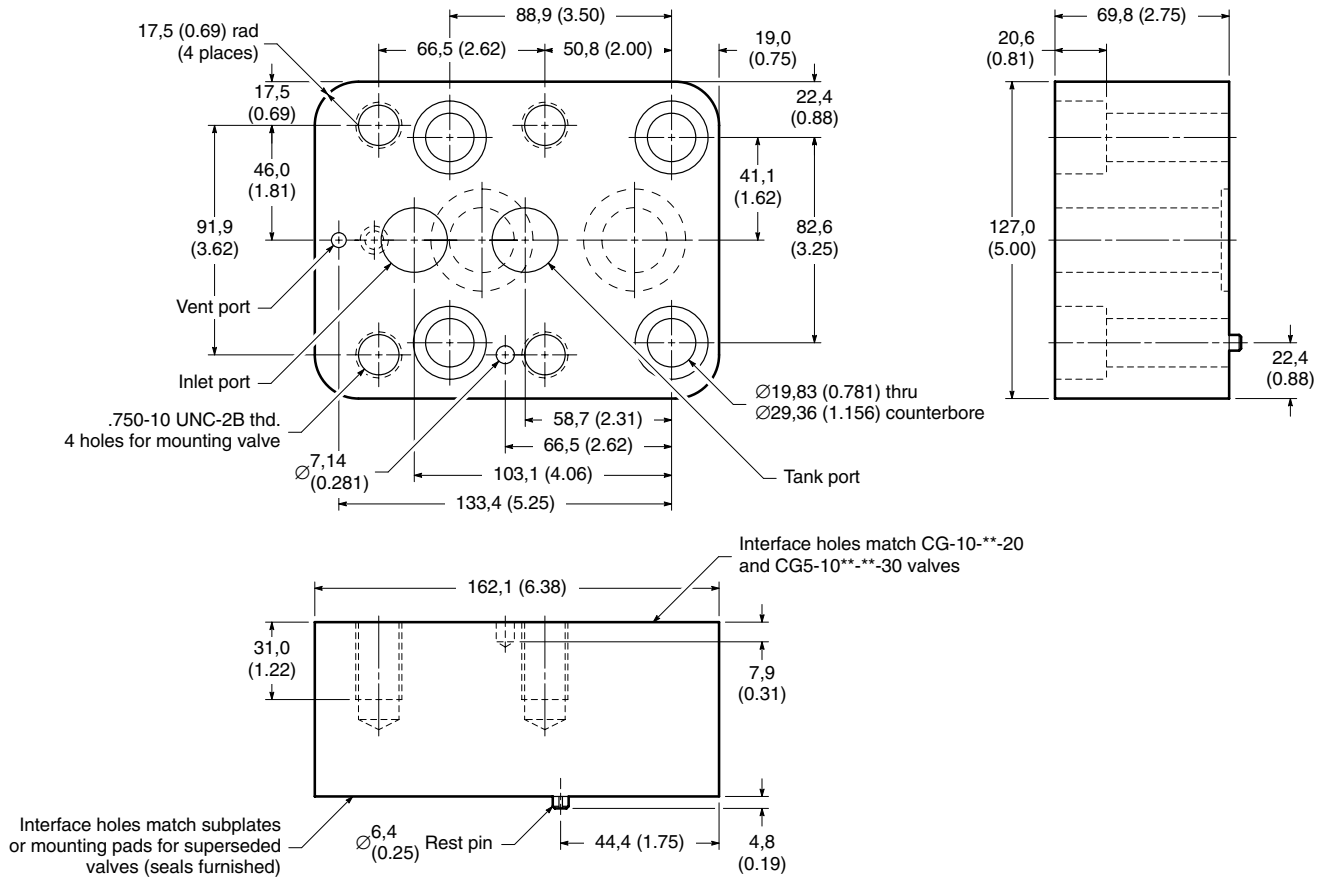

Series C*5-03/06/10 Pilot Operated Relief Valves

Model Code

(F3) C S 5 - (H) 06 2 A (P) C (V) - M (S1) (PA5) - W (L) - B (9) - P08 - 100

1 Seals

F3 – For CG5 all internal seals are F3. Interface seals are Buna-N. Add prefix F3 to model for use with synthetic fluids.
Blank – Omit for CS5 and CT5 (all seals are F3 as standard)

2 Valve Type

C – Relief valve

3 Connections

G – Manifold or subplate mounting (not available in 03 size valve)
S – SAE straight thread
T – NPTF thread* (not available in 03 size valve)

*Not recommended

4 Control Type

5 – Solenoid controlled (pilot operated)

5 High-flow Designation

H – High-flow valve (not available in CT models)
Blank – Omit if not required

6 Valve Size

03 – .8750-14 UNF-2B straight thread (0.625 tubing)
06 – 1.0625-12 UN-2B straight thread (0.750 tubing) or 3/4" pipe
10 – 1.6250-12 UN-2B straight thread (1.250 tubing) or 1 1/4" pipe

7 Pilot Spool Function

0, 1, or 2 – Indicates venting condition. See Graphical Symbols on page 31.

8 Pilot Spool Spring Arrangement

A – Spring offset
C – Spring centered
F – Energize to center

9 Manual Override

P – Plain override in end cap (single solenoid models only)
Blank – Omit if not required

10 Pressure Range

B – 8,5 to 70 bar (125 to 1000 psi)
C – 35 to 140 bar (500 to 2000 psi)
F – 100 to 210 bar (1500 to 3000 psi)

11 High Vent Spring

V – Optional high vent spring installed (required in high-flow models)
Blank – Omit if not required

12 Flag Symbol

M – Electrical options and features

13 Spool Indicator Switch

For spring offset (A) models only. Not available in manual override models.
S – Switch unwired
S1 – Switch wired normally open
S2 – Switch wired normally closed

14 Electrical Connections

PA3 – 3-pin receptacle (single solenoid models only)
PA5 – 5-pin receptacle
PB – "Insta-Plug" with male and female connectors
Blank – Omit if not required

15 Housing

U – ISO 4400 (DIN 43650) connector (For use with indicator lights, contact your Vickers representative.)
W – 1/2" NPT thread wiring housing
WL – 1/2" NPT thread wiring housing with coil indicator lights

16 Coil Voltage Rating

B – 115/120V AC 60 Hz and 110V AC 50 Hz
D – 230V AC 60 Hz and 220/230V AC 50 Hz
F – 6V DC
G – 12V DC
H – 24V DC

17 Coil Wattage

9 – Low wattage coil (B coil only)
Blank – Omit if not required

18 Pilot Valve Port Orifices

***00** – Solid plug
***03** – 0,30 (0.012)
***06** – 0,60 (0.024)
***08** – 0,80 (0.030)
***10** – 1,00 (0.040)
***13** – 1,30 (0.050)
***15** – 1,50 (0.060)
***20** – 2,00 (0.080)
***23** – 2,30 (0.090)
Blank – Omit if not required

* = P, T, A, or B as required

19 Design Number

100 – For CS5 and CT5 models (using DG4V-3S pilot valve)
110 – For CG5 models (using DG4V-3 high performance pilot valve)

Subject to change. Installation dimensions same for designs 100 through 109 and for designs 110 through 119.

General Data

All valves are of the patented Vickers balanced piston type construction. These valves are generally used for applications requiring an electrically controlled adjustable pressure relief or regulating valve to limit the pressure in an oil circuit to the desired maximum.

Pressure Adjustment

Select pressure range so that excessively high working pressures will not be imposed upon pump or other equipment.

Adjustment of pressure is accomplished by loosening jam nut and turning adjusting screw. Clockwise rotation increases pressure; counterclockwise rotation decreases pressure.

Application Guidance High Flow Valve (“H” Model)

“H” series valves require use of a high vent spring (C*5-(H)06/10**-*V-***-1**).

Typical Spool Shift Time

Note

Any sliding spool valve, if held shifted under pressure for long periods of time, may stick and not spring return due to fluid residue formation and, therefore, should be cycled periodically to prevent this from happening.

Following is typical spool shift time* for spring offset and spring centered models (rated flow and pressure):

Solenoid Energized	
AC	12 ms
DC	30 ms
Spring Return	
AC (all spools except 2)	22 ms
AC (type 2) and DC (all models)	45 ms
Offset to Offset on Spring Centered Models	
AC	25 ms
DC	60 ms
Maximum Cycling Rate (all spool positions actuated once/cycle)	
AC	4 Hz
DC	3 Hz

* Shift times apply to solenoid pilot valve only.

Installation Data Tank Connection

The tank connection should be piped directly to tank to minimize back pressure. Any back pressure in the tank line is additive to the valve pressure setting. If tank line back pressure exceeds system pressure by 7,0 bar (100 psi), a malfunction may occur. Transient pressure peaks in the tank line must not exceed 155 bar (2250 psi).

Note

Surges of oil in a common tank line serving these and other valves can be of sufficient magnitude to cause inadvertent shifting of the pilot spool of the valves. Separate tank lines or a vented manifold with a continuous downward path to tank is necessary.

Mounting

Mounting orientation is unrestricted.

Electrical Information

AC solenoids furnished with this valve are dual frequency types (as shown in the table on page 30). They also resist burn-out, which allows time to find and correct problems before solenoid burn-out occurs.

Solenoids

Solenoids are identified by a letter in the model number. Example: CG5-062C-B-M-W-B-110.

Note

Solenoids are designed to function continuously at $\pm 10\%$ of rated voltage.

Note

On all models, when solenoid “A” is energized, flow is always P→A. When solenoid “B” is energized, flow is always P→B. This is in accordance with ANSI-B93.9 standard. Solenoid “A” and “B” are identified on diagram on top of valve. This orientation is reversed for left hand “L” models.

Ratings

Rated Pressure (Maximum)	210 bar (3000 psi)
Rated Capacity (Maximum)	
CS5-03 & C*5-06	227 l/min (60 USgpm)
C*5-H06	340 l/min (90 USgpm)
C*5-10	454 l/min. (120 USgpm)
C*5-H10	680 l/min (180 USgpm)

Series C*5-03/06/10 Pilot Operated Relief Valves

Solenoid Energizing

Spring centered and spring offset types will be spring positioned unless solenoid is energized continuously.

The conduit connection readily adapts to connector receptacle assemblies on the market.

Electrical Connection Note

1/2 NPT thread for C*5(H)****-M-W*-90 models is provided on both ends of the wiring box. the wiring box is a NEMA type 4 enclosure.

Solenoid Indicator Lights

Light is “on” when there is current at the coil. Lights are available for most AC and DC voltages.

Lead wire insulation Class “H” on both AC and DC solenoid lead wires

Wiring

The electrical connections to the valve are made in the electrical wiring housing. Two lead wires for each solenoid, approximately 153,0mm (6.00 in.) long, with M3 (No. 6) size terminals are provided for customer connection. A ground terminal is also provided.

Seals

Threaded Valves:

All seals used in the threaded valves are fluorocarbon as standard and are suitable for use with phosphate ester type fluids or its blends, water glycol, water-in-oil emulsions, and petroleum oil.

Subplate Mounted Valves:

Standard models are furnished with Buna-N seals for the mounting surface and may be used with water glycol, water-in-oil emulsions, and petroleum oil. Internal seals are fluorocarbon. The use of phosphate ester or its blends requires an F3 model. All seals of the F3 models are fluorocarbon, including the mounting surface seals.

Subplates and Bolt Kits

Valves, subplates, and mounting bolts must be ordered separately.

Example:

- (1) CG5-062C-F-M-W- * -110 valve
- (1) CGM-06S-20 subplate
- (1) BKCG06604 bolt kit (consisting of four bolts, 5/8-11 x 2.75”)

CGM-06S-20 and CGM-10S-20 subplate installation dimensions are shown in CG-06/10 section. When a subplate is not used, a machined pad (as indicated by subplate shaded area on pages 24 and 25) must be provided for mounting. The pad must be flat within 0,013 mm (0.0005 in) and smooth within 1,6 μm (63 microinch). Mounting bolts provided by the customer should be SAE grade 7 or better.

Solenoid Voltage Rating	Identification Letter	Inrush amps (R.M.S.)*	Holding amps	Holding watts	Resistance ohms @20°C	Inductance mH
115/120V AC 60 Hz	B	2.0	0.54	31	33.5	185
110V AC 50 Hz			0.64			
230/240V AC 60 Hz	D	1.0	0.27	31	140	731
220V AC 50 Hz			0.32			
24V AC 60 Hz	N	7.8	2.45	27	1.60	57
24V AC 50 Hz		8.4	3.15	35		
115/120V AC 60 Hz	B9 (Low Watt)	1.5	0.31	17	55.0	285
110V AC 50 Hz			0.37	21		
110V AC 60 Hz	T	1.9	0.66	27	23.1	150
110V AC 50 Hz		2.1	0.85	35		
6V DC	F	—	6.8	41	0.88	4.07
12V DC	G	—	3.5	41	3.45	16.3
24V DC	H	—	1.7	41	13.9	64.6
32V DC	DK	—	1.3	41	24.7	114
48V DC	J	—	0.87	41	55.3	258

* Maximum peak inrush amps approximately 1.4 x R.M.S value shown

Graphical Symbols

Model C*5-(H)0C (DG4V-3-0C Pilot)**

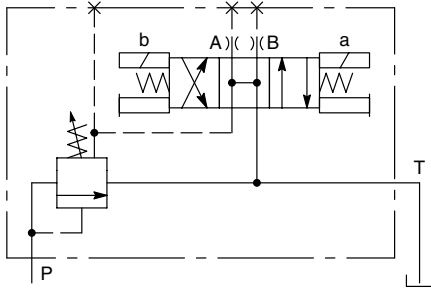

When solenoid “A” is energized, control is at connection “A”. When solenoid “B” is energized, control is at connection “B”. When both solenoids are de-energized, valve is vented.

Model C*5-(H)2C (DG4V-3-2C Pilot)**

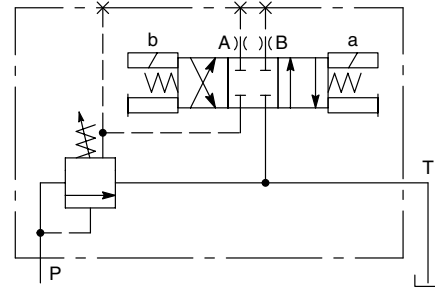

When solenoid “A” is energized, control is at connection “A”. When solenoid “B” is energized, control is at connection “B”. When both solenoids are de-energized, control is by integral adjustment.

Model C*5-(H)0A (DG4V-3-0BL Pilot)**

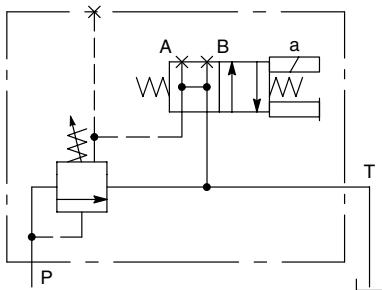

When solenoid “A” is energized, control is by integral adjustment. When solenoid “A” is de-energized, valve is vented.

Model C*5-(H)1A (DG4V-3-2AL Pilot)**

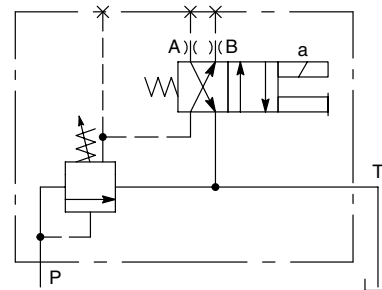

When solenoid “A” is energized, control is at connection “A”. When solenoid “A” is de-energized, control is at connection “B”.

Model C*5-(H)2A (DG4V-3-2BL Pilot)**

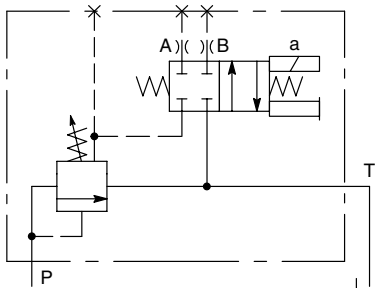

When solenoid “A” is energized, control is at connection “A”. When solenoid “A” is de-energized, control is by integral adjustment.

Model C*5-(H)0E (DG4V-3-0FL Pilot)**

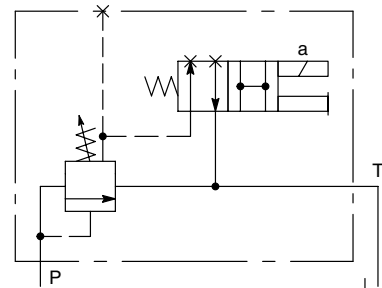

When solenoid “A” is energized, valve is vented. When solenoid “A” is de-energized, control is by integral adjustment.

Series C*5-03/06/10 Pilot Operated Relief Valves

Performance Curves

Subplate or Manifold Mounted Models

Nominal Override Characteristics

- CG5-06
- ▲ CG5-10

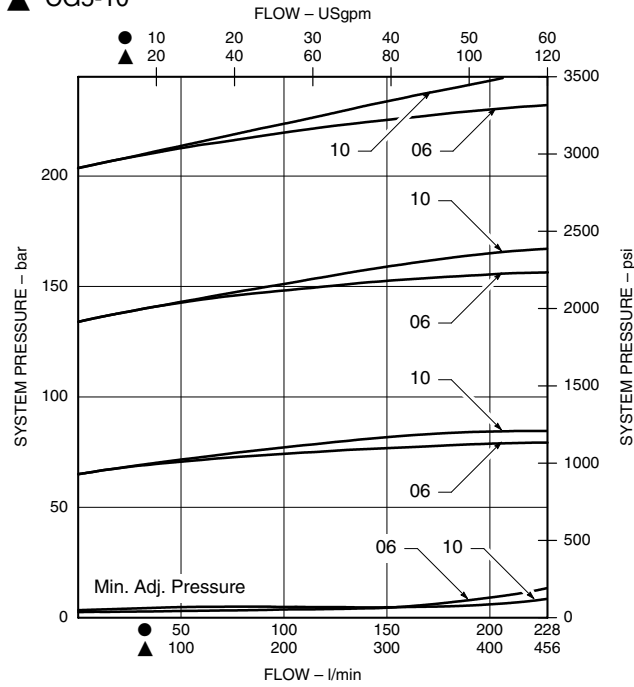

- ◆ CG5-H06
- CG5-H10

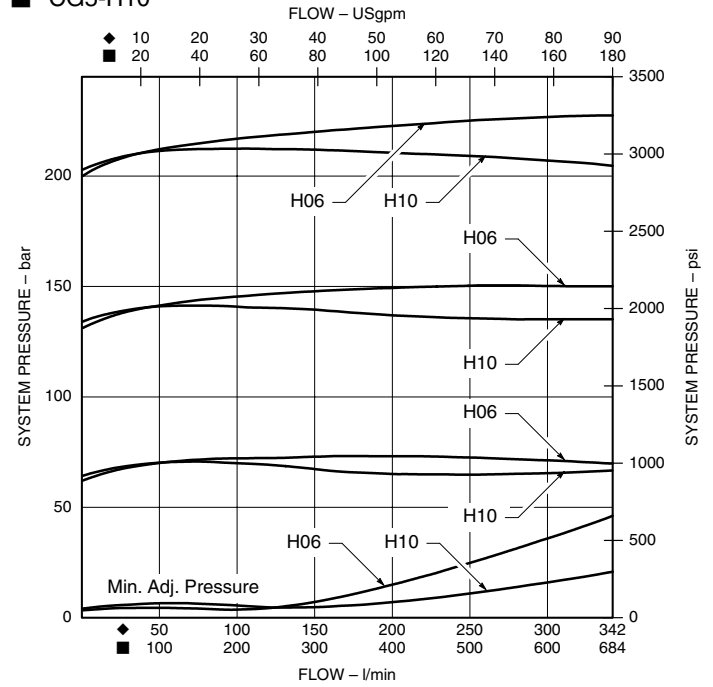

Vent Pressure Versus Flow*

- CG5-06
- ▲ CG5-10

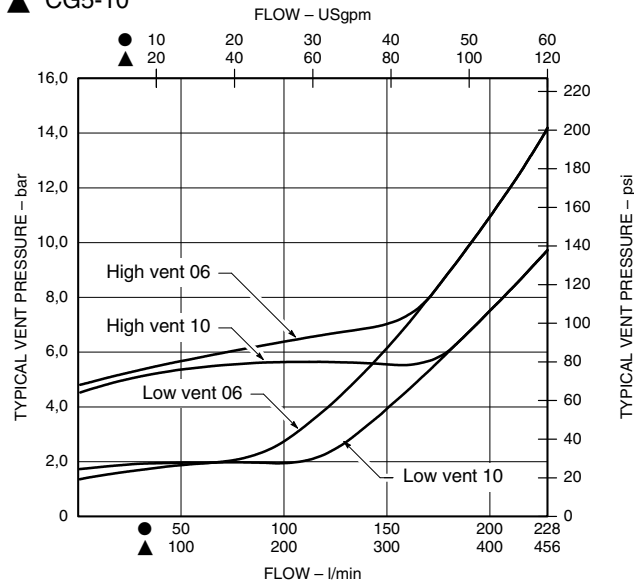

- ◆ CG5-H06
- CG5-H10

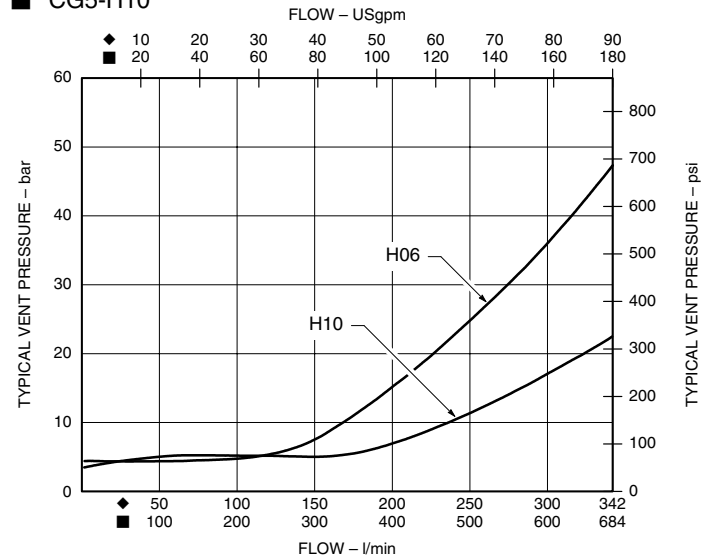

* Valves supplied with external pilot connections (model designation "0C", "2C", "1A", and "2A") have an integral damping orifice. If these models are vented through their pilot connections, the vent pressures will be approximately 1,7 bar (25 psi) higher than shown.

Threaded Port Models

Nominal Override Characteristics

● C*5-03/06

▲ C*5-10

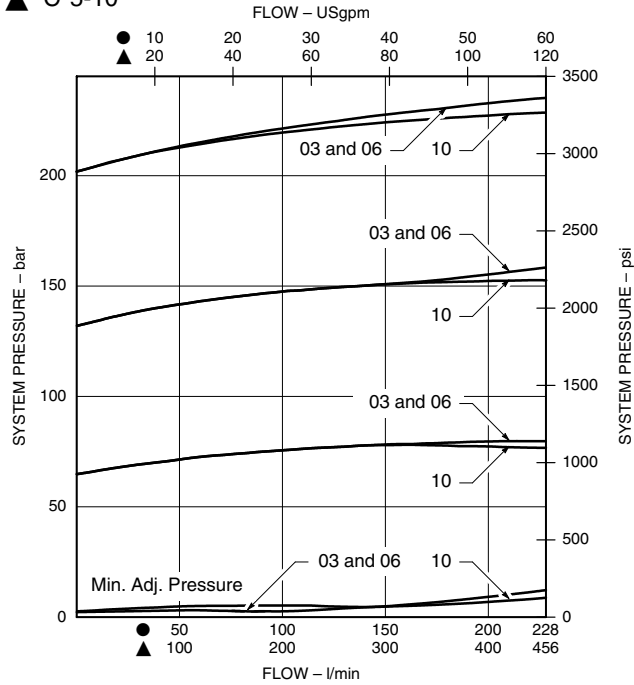

◆ C*5-H06

■ C*5-H10

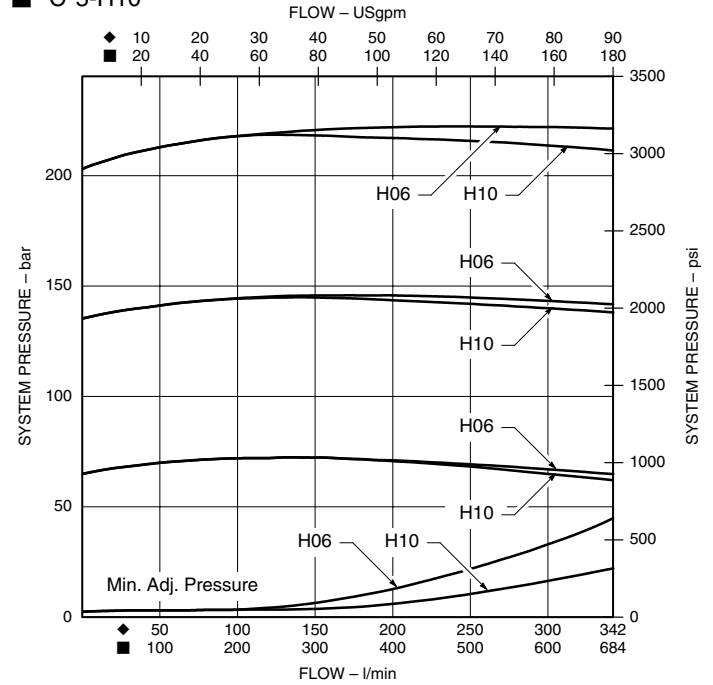

Vent Pressure Versus Flow*

● C*5-03/06

▲ C*5-10

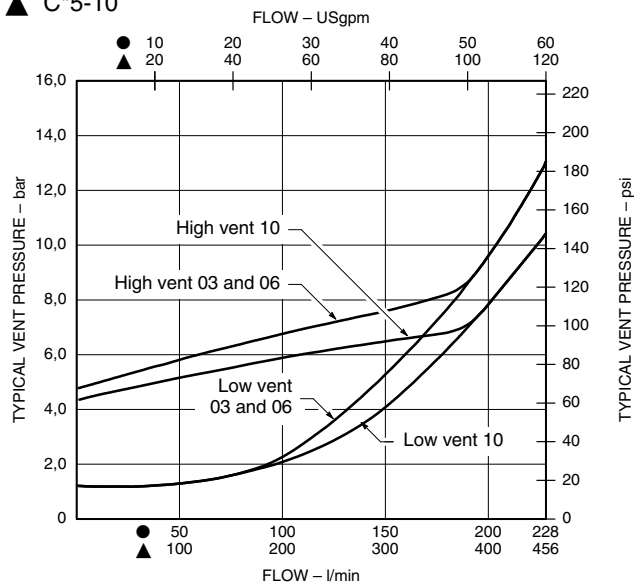

◆ C*5-H06

■ C*5-H10

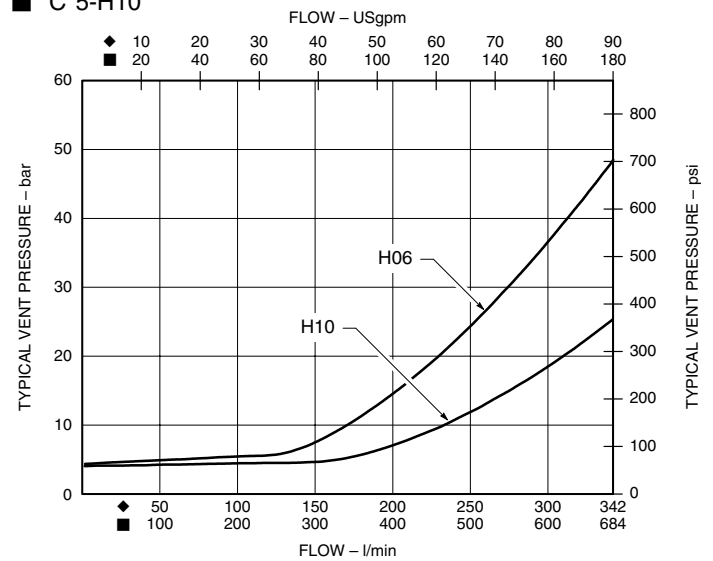

* Valves supplied with external pilot connections (model designation "0C", "2C", "1A", and "2A") have an integral damping orifice. If these models are vented through their pilot connections, the vent pressures will be approximately 1,7 bar (25 psi) higher than shown.

Series C*5-03/06/10 Pilot Operated Relief Valves

Installation Dimensions

mm (inch)

Subplate or Manifold Mounted Models

Double Solenoid Spring Centered Type
CG5-(H)***C-**-M-**-110 Series

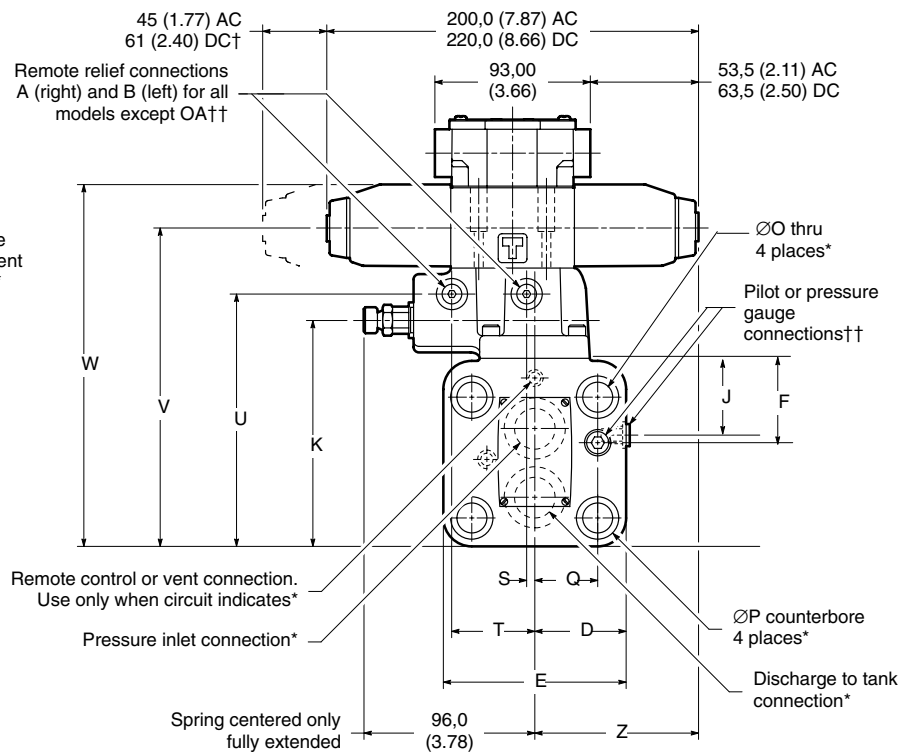
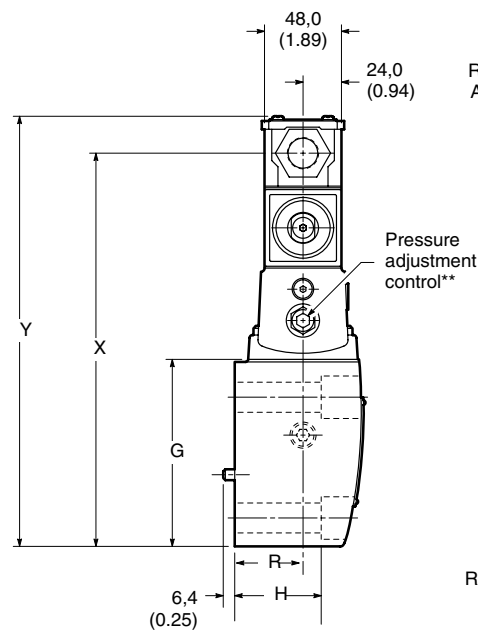
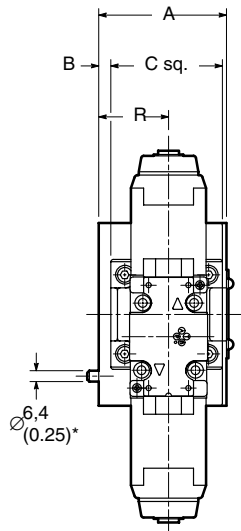

Note

See page 35 for tabulated dimensions.

* See mounting subplates for locating dimensions.

** Use 7,92 (0.312) hex key.

† Clearance for removal of solenoid coil.

†† .4375-20 UNF-2B straight thread for 0.250 O.D. tubing.

**Single Solenoid Spring Offset Type
CG5-(H) *** A- ** -M- * - * -110 Series**

(See page 34 for other details and dimensions)

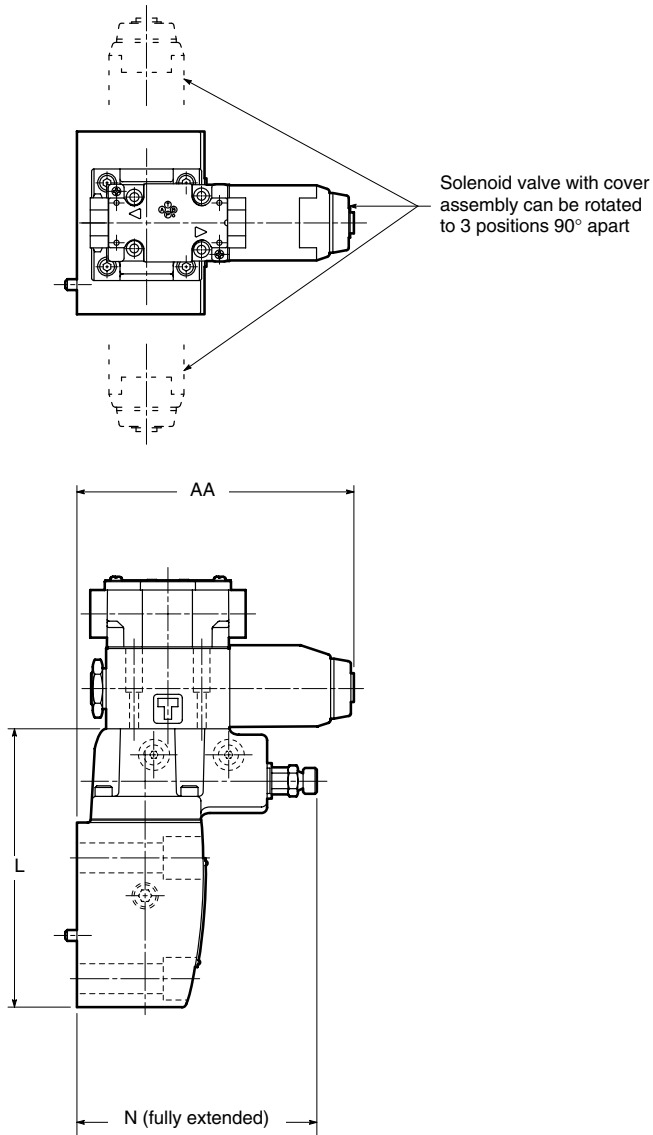

Model	A	B	C	D	E	F	G	H	J	K	L	M	N	O
CG5-06	71,4 (2.81)	7,9 (0.31)	62,0 (2.44)	53,3 (2.10)	106,4 (4.19)	47,8 (1.88)	107,2 (4.22)	47,8 (1.88)	42,9 (1.69)	131,1 (5.10)	156,5 (6.16)	106,7 (4.20)	134,9 (5.31)	16,6 (0.65)
CG5-(H)10	85,9 (3.38)	2,3 (0.09)	81,0 (3.19)	66,8 (2.63)	133,4 (5.25)	55,6 (2.19)	116,1 (4.57)	63,5 (2.50)	50,8 (2.00)	141,5 (5.57)	168,4 (6.63)	110,7 (4.36)	138,9 (5.47)	19,8 (0.78)

Model	P	Q	R	S	T	U	V	W	X	Y (AC)	Y (DC)	Z (AC)	Z (DC)
CG5-06	24,5 (0.96)	35,1 (1.38)	4,0 (0.16)	46,0 (1.81)	143,8 (5.66)	181,4 (7.14)	207,3 (8.16)	225,3 (8.87)	247,1 (9.73)	89,0 (3.50)	98,8 (3.89)	206,4 (8.12)	234,4 (9.22)
CG5-(H)10	29,3 (1.15)	46,0 (1.81)	5,6 (0.22)	48,5 (1.91)	155,7 (6.13)	193,3 (7.61)	219,2 (8.63)	237,2 (9.34)	259,1 (10.2)	85,0 (3.34)	94,8 (3.73)	54,6 (2.14)	68,5 (2.69)

Model	AA	BB
CG5-06	11,4 (0.45)	84,8 (3.34)
CG5-(H)10	17,0 (0.67)	91,2 (3.59)

Series C*5-03/06/10 Pilot Operated Relief Valves

Threaded Port Models

mm (inch)

Double Solenoid Spring Centered Type CS/T5-(H) *** C- ** -M- * - * - 100 Series

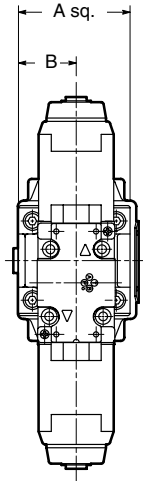

Note

See page 37 for tabulated dimensions.

* Use 7,92 (0.312) hex key.

** .4375-20 UNF-2B straight thread for 0.250 O.D. tubing.

† Clearance for removal of solenoid coil.

†† .7500-16 UNF-2B thread for 0.500 O.D. tubing.

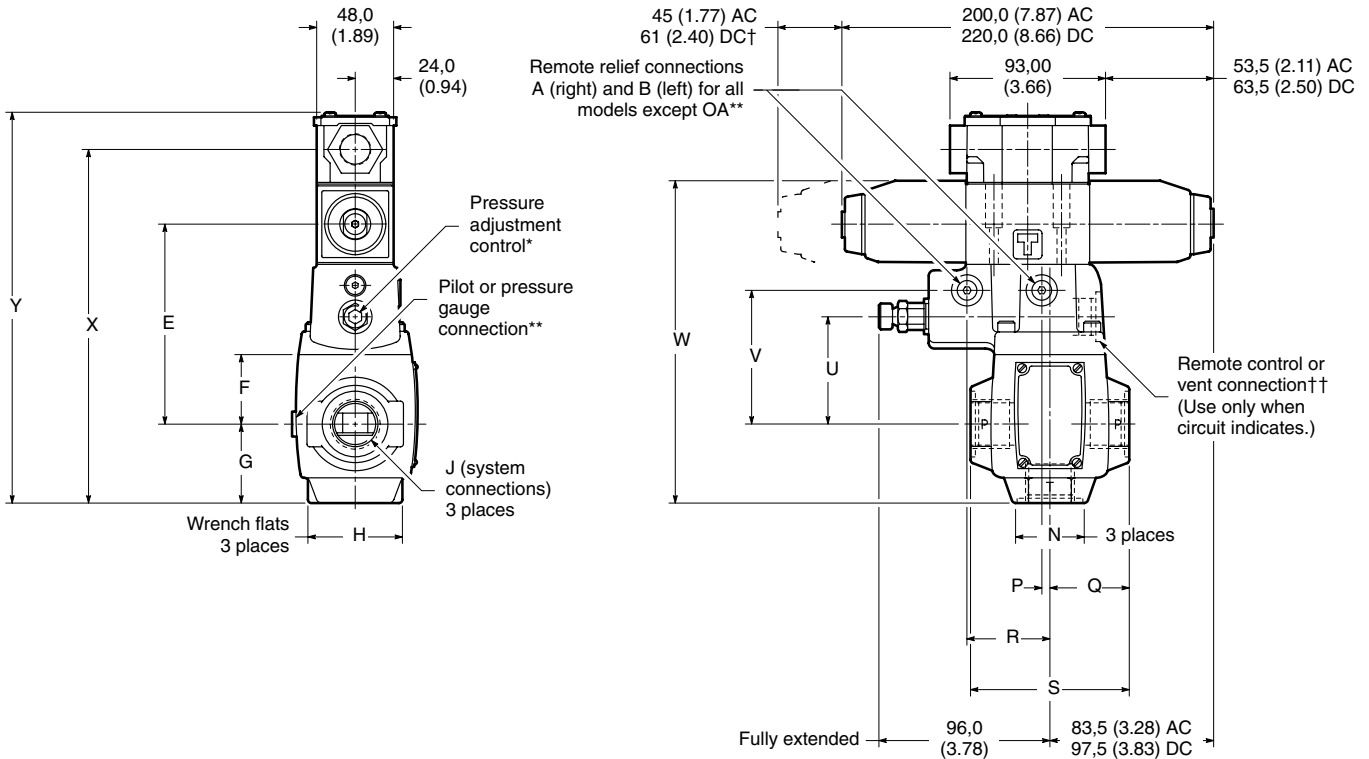

**Single Solenoid Spring Offset Type
CS/T5-(H) *** A- ** -M- * -100 Series**

(See page 36 for other details and dimensions)

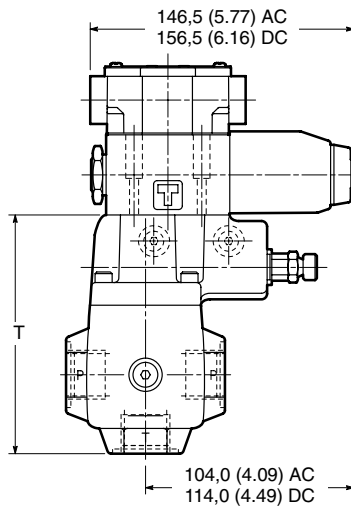
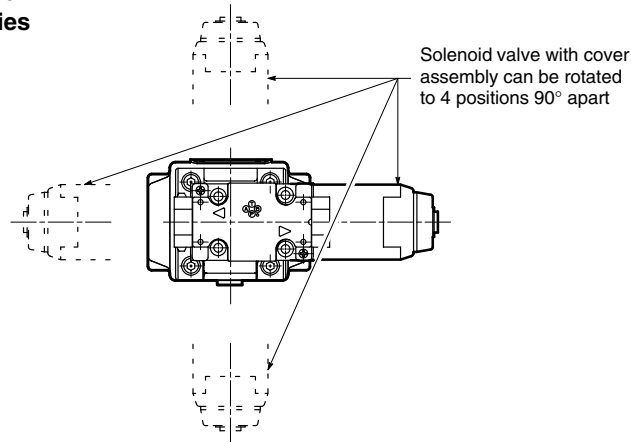

Model	A	B	C	D	E	F	G	H	J
CS/T5-03	65,0 (2.56)	32,5 (1.28)	229,9 (9.05)	213,4 (8.40)	113,8 (4.48)	39,6 (1.56)	55,6 (2.19)	53,8 (2.12)	CS5-03: .8750-14 UNF-2B thd. for 0.625 O.D. tubing
CS/T5-(H)06/10	83,3 (3.28)	41,7 (1.64)	240,9 (9.48)	224,2 (8.83)	118,6 (4.67)	41,1 (1.62)	62,0 (2.44)	69,9 (2.75)	CS5-(H)06: .062-12 UN-2B thd. for 0.750 O.D. tubing CS5-(H)10: 1.6250-12 UN-2B thd. for 1.250 O.D. tubing CT5-06: 3/4" NPTF thd. ■ CTS-10: 1 1/4" NPTF thd. ■

Model	K	L	M	N	P	Q	R	S	T
CS/T5-03	195,5 (7.70)	76,2 (3.00)	62,0 (2.44)	45,7 (1.80)	4,0 (0.16)	47,8 (1.88)	46,0 (1.81)	95,5 (3.76)	144,5 (5.69)
CS/T5-(H)06/10	206,5 (8.13)	81,0 (3.19)	66,5 (2.62)	62,0 (2.44)	5,59 (0.22)	62,0 (2.44)	48,5 (1.91)	124,0 (4.88)	155,5 (6.12)

■ Not recommended

Series C*19-06/10 Air Operated Relief Valves

Model Code

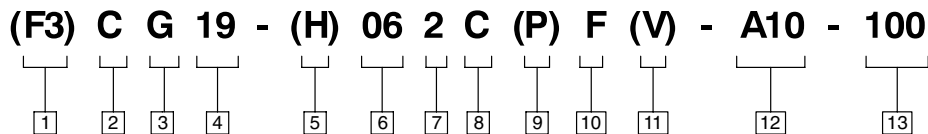

1 Seals

F3 – For CG19 all internal seals are F3. Interface seals are Buna-N. Add prefix F3 to model for use with mineral oil and fire resistant fluids.

Blank – Omit for CS5 and CT5 (all seals are F3 as standard)

2 Valve Type

C – Relief valve

3 Connections

G – Manifold or subplate mounting (not available in 03 size valve)

T – NPTF thread*

*Not recommended

4 Control Type

19 – Air controlled (pilot operated)

5 High-flow Designation

H – High-flow valve (not available in CT models)

Blank – Omit if not required

6 Valve Size

06 – 1.0625-12 UN-2B straight thread (0.750 tubing) or 3/4" pipe

10 – 1.6250-12 UN-2B straight thread (1.250 tubing) or 1 1/4" pipe

7 Pilot Spool Function

0, 1, or 2 – Indicates venting condition. See Graphical Symbols on page 46.

8 Pilot Spool Spring Arrangement

A – Spring offset

C – Spring centered

F – Pressurize to center

9 Manual Override

P – Plain override in end cap (single operator models only)

Blank – Omit if not required

10 Pressure Range

B – 8,5 to 70 bar (125 to 1000 psi)

C – 35 to 140 bar (500 to 2000 psi)

F – 100 to 210 bar (1500 to 3000 psi)

11 High Vent Spring

V – Optional high vent spring installed (required in high-flow models)

Blank – Omit if not required

12 Pilot Valve Port Orifices

***00** – Solid plug

***03** – 0,30 (0.012)

***06** – 0,60 (0.024)

***08** – 0,80 (0.030)

***10** – 1,00 (0.040)

***13** – 1,30 (0.050)

***15** – 1,50 (0.060)

***20** – 2,00 (0.080)

***23** – 2,30 (0.090)

Blank – Omit if not required

* = P, T, A, or B as required

13 Design Number

Subject to change. Installation dimensions same for designs 100 through 109 (using -60 design DG18V-3 pilot valve).

General Data

C*19-06/10 valves are of balanced piston type construction. These valves are generally used for applications requiring an air controlled adjustable pressure relief or regulating valve to limit the pressure in an oil circuit to the desired maximum.

Pressure Adjustment

Select a pressure range such that excessively high working pressures will not be imposed upon the pump or other equipment.

Adjustment of pressure is accomplished by loosening jam nut and turning adjusting screw. Clockwise rotation increases pressure; counterclockwise rotation decreases pressure.

Application Guidance

High Flow Valve ("H" Model)

The "H" series valves require the use of a high vent spring (C*19-(H)06/10**-***V**-**-*-1**).

Installation Data

Tank Connection

The tank connection should be piped directly to tank to minimize back pressure. Any back pressure in the tank line is additive to the valve pressure setting. If tank line back pressure exceeds system pressure by 7 bar (100 psi), a malfunction may occur. Transient pressure peaks in the tank line must not exceed 155 bar (2250 psi).

Note

Surges of oil in a common tank line serving these and other valves can be of sufficient magnitude to cause inadvertent shifting of the pilot spool of the valves. Separate tank lines or a vented manifold with a continuous downward path to tank is necessary.

Mounting

Mounting orientation is unrestricted.

Seals

Threaded Valves:

All seals used in the threaded valves are fluorocarbon as standard and are suitable for use with phosphate ester type fluids or its blends, water glycol, water-in-oil emulsions, and petroleum oil.

Subplate Mounted Valves:

Standard models are furnished with Buna-N seals for the mounting surface and may be used with water glycol, water-in-oil emulsions, and petroleum oil. Internal seals are fluorocarbon. The use of phosphate ester or its blends requires an F3 model. All seals of the F3 models are fluorocarbon, including the mounting surface seals.

Subplates and Bolt Kits

Valves, subplates, and mounting bolts must be ordered separately.

Example:

- (1) CG19-062C-F-10* valve
- (1) CGM-06S-20 subplate
- (1) BKCG06604 bolt kit (consisting of four bolts, $\frac{5}{8}$ -11 x 2.75")

CGM-06S-20 and CGM-10S-20 subplate installation dimensions are shown in CG-06/10 section. When a subplate is not used, a machined pad (as indicated by subplate shaded area on pages 24 and 25) must be provided for mounting. The pad must be flat within 0,013 mm (0.0005 in) and smooth within 1,6 μ m (63 microinch). Mounting bolts provided by the customer should be SAE grade 7 or better.

Graphical Symbols

See page 46 for C*19-06/10 graphical symbols.

Ratings

Rated Pressure (Maximum)	210 bar (3000 psi)
Rated Capacity (Maximum)	
CG/T19-06	227 l/min (60 USgpm)
CG/T19-H06	340 l/min (90 USgpm)
CG/T19-10	454 l/min. (120 USgpm)
CG/T19-H10	680 l/min (180 USgpm)
Maximum Air Pilot Pressure	10 bar (150 psi)
Minimum Air Pilot Pressure	1,0 bar (15.0 psi)

Series C*19-06/10 Air Operated Relief Valves

Performance Curves

Subplate or Manifold Mounted Models

Nominal Override Characteristics

- CG19-06
- ▲ CG19-10

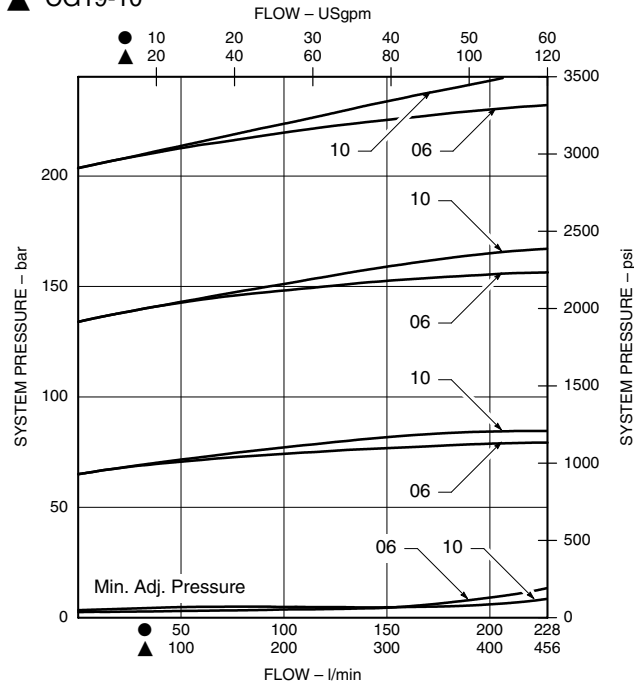

- ◆ CG19-H06
- CG19-H10

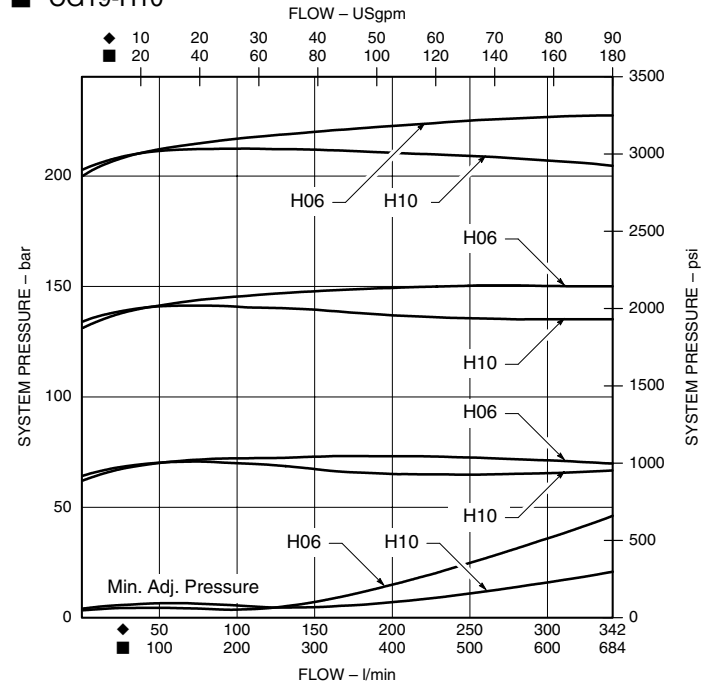

Vent Pressure Versus Flow*

- CG19-06
- ▲ CG19-10

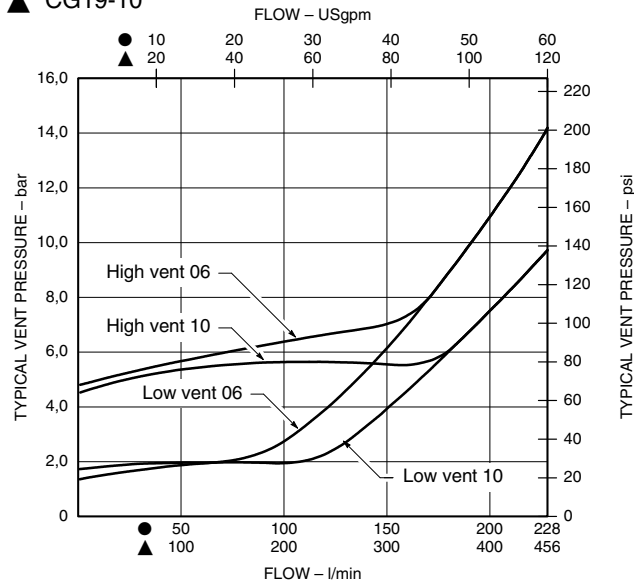

- ◆ CG19-H06
- CG19-H10

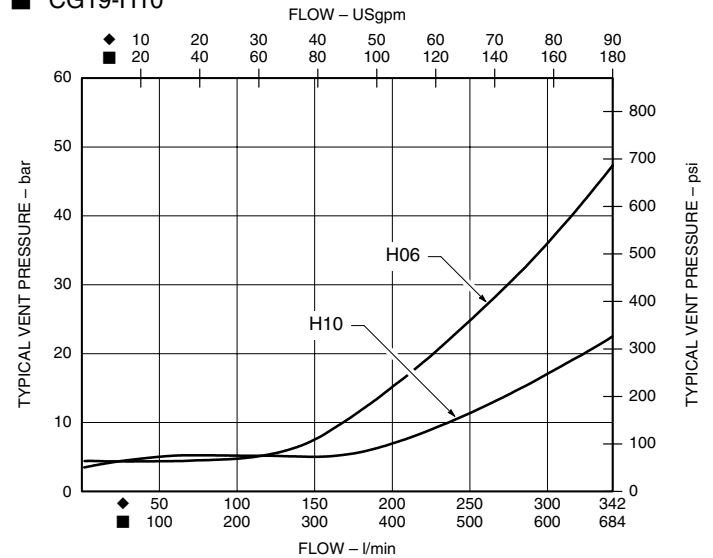

* Valves supplied with external pilot connections (model designation "0C", "2C", "1A", and "2A") have an integral damping orifice. If these models are vented through their pilot connections, the vent pressures will be approximately 1,7 bar (25 psi) higher than shown.

Threaded Port Models

Nominal Override Characteristics

- CT19-06
- ▲ CT19-10

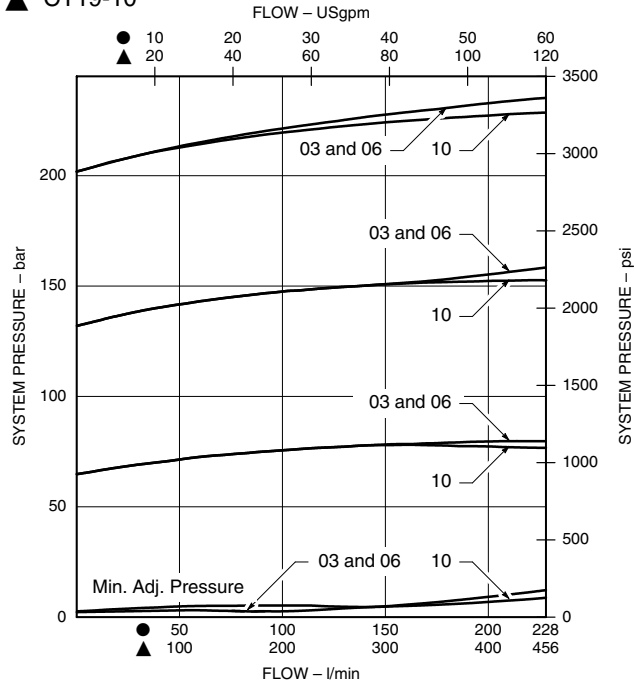

- ◆ CT19-H06
- CT19-H10

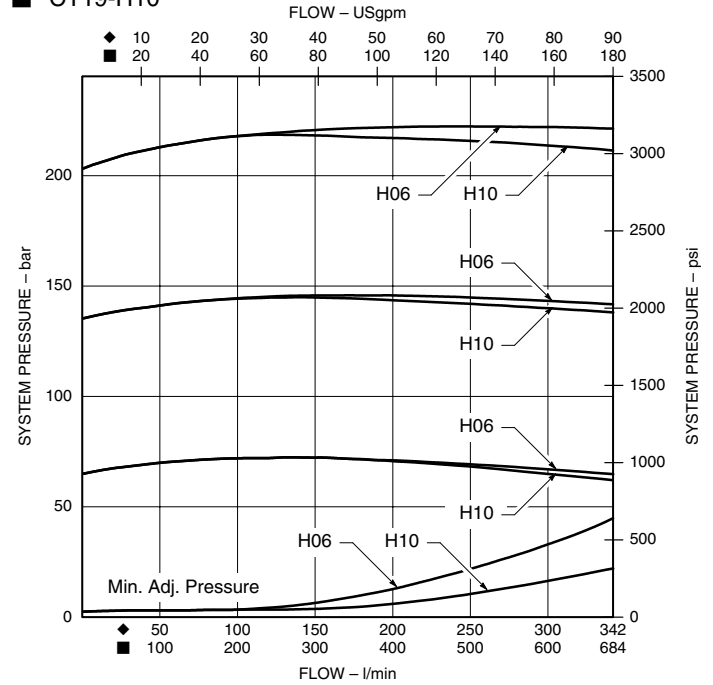

Vent Pressure Versus Flow*

- CT19-06
- ▲ CT19-10

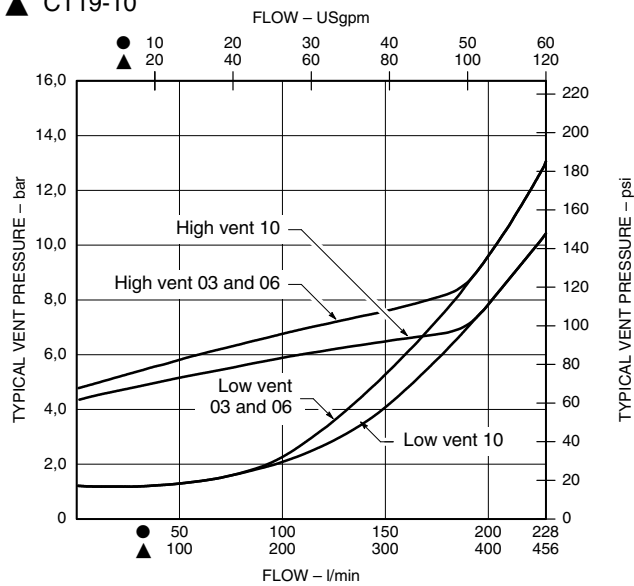

- ◆ CT19-H06
- CT19-H10

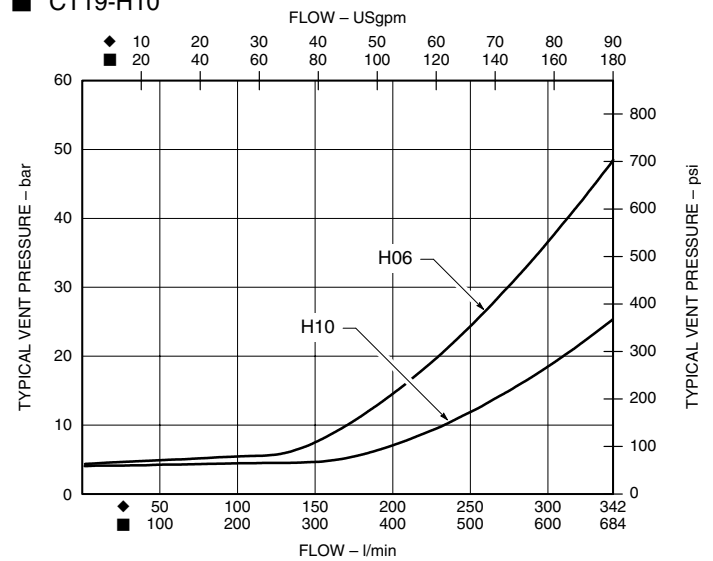

* Valves supplied with external pilot connections (model designation "0C", "2C", "1A", and "2A") have an integral damping orifice. If these models are vented through their pilot connections, the vent pressures will be approximately 1,7 bar (25 psi) higher than shown.

Series C*19-06/10 Air Operated Relief Valves

Installation Dimensions

mm (inch)

Subplate or Manifold Mounted Models

Double Operator Spring Centered Type
CG19-(H) *** C- * * * - * * - 100 Series

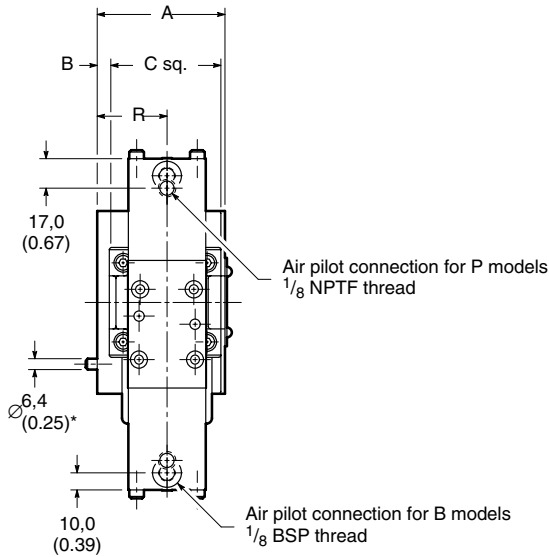

Note

See page 43 for tabulated dimensions.

* See mounting subplates for locating dimensions.

** Use 7,92 (0.312) hex key.

† .4375-20 UNF-2B straight thread for 0.250 O.D. tubing.

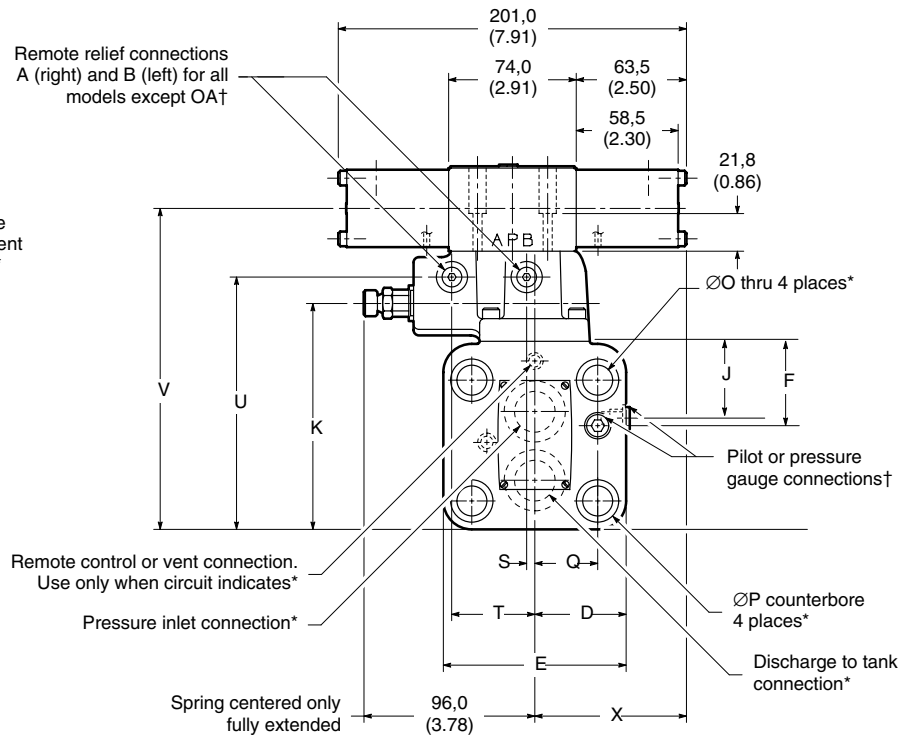
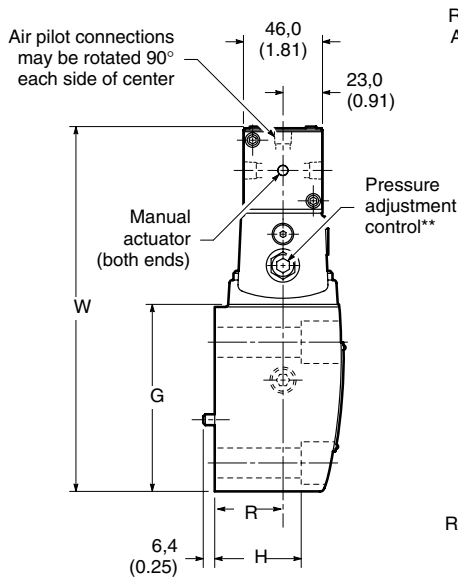

**Single Operator Spring Offset Type
CG19-(H) *** A- ** - * - * - 100 Series**

(See page 42 for other details and dimensions)

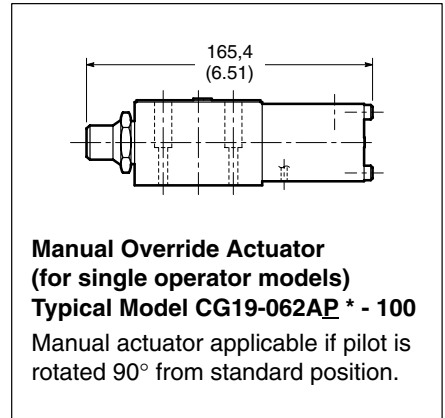
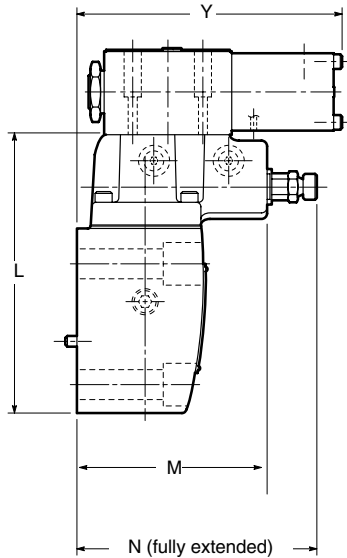
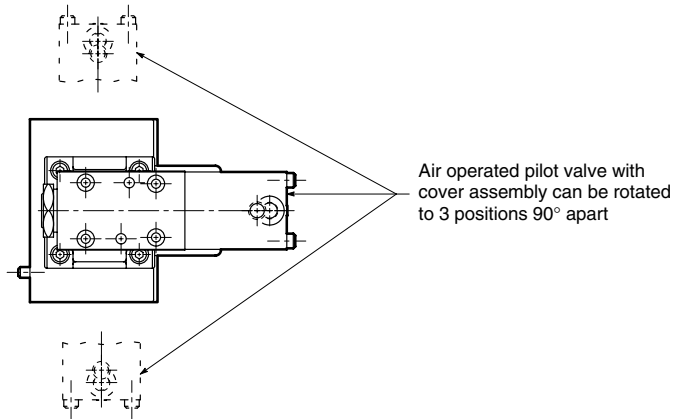

Model	A	B	C	D	E	F	G	H	J	K	L	M
CG19-06	71,4 (2.81)	7,9 (0.31)	62,0 (2.44)	53,3 (2.10)	106,4 (4.19)	47,8 (1.88)	107,2 (4.22)	63,5 (2.50)	50,8 (2.00)	129,5 (5.10)	156,5 (6.16)	100,8 (3.97)
CG19-(H)10	85,9 (3.38)	2,3 (0.09)	81,0 (3.19)	66,8 (1.69)	133,4 (8.59)	55,6 (7.59)	116,1 (4.57)	63,5 (2.50)	50,8 (2.00)	141,5 (5.57)	164,6 (0.22)	104,7 (1.81)

Model	N	O	P	Q	R	S	T	U	V	W	X	Y
CG19-06	159,5 (6.28)	16,6 (0.65)	24,5 (0.96)	35,1 (1.38)	38,9 (1.53)	4,0 (0.16)	46,0 (1.81)	143,8 (5.66)	180,8 (7.12)	206,2 (8.12)	85,1 (3.35)	153,4 (6.04)
CG19-(H)10	163,6 (1.91)	19,8 (0.78)	29,3 (1.15)	46,0 (1.81)	42,9 (1.69)	4,0 (0.16)	48,5 (1.91)	155,7 (6.13)	192,8 (7.59)	218,2 (8.59)	85,0 (3.35)	159,0 (6.26)

Series C*19-06/10 Air Operated Relief Valves

Threaded Port Models

mm (inch)

Double Operator Spring Centered Type

CT19-***C-**-M-**-100 Series

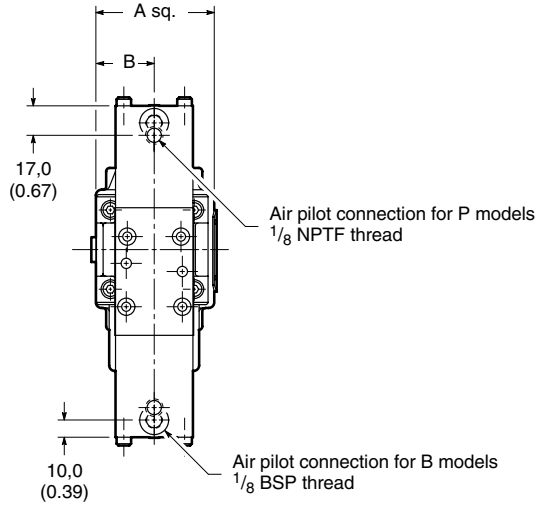

Note

See page 45 for tabulated dimensions.

* Use 7,92 (0.312) hex key.

** .4375-20 UNF-2B straight thread for 0.250 O.D. tubing.

† .7500-16 UNF-2B thread for 0.500 O.D. tubing.

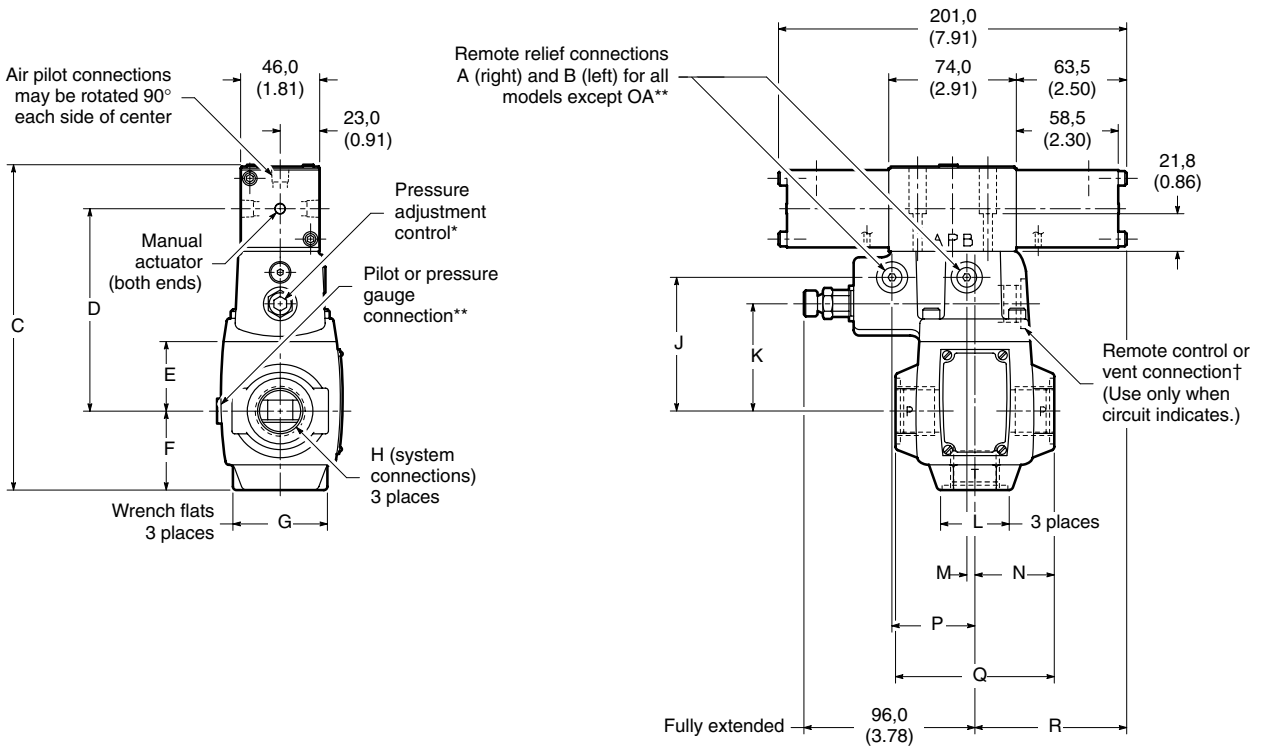

**Single Operator Spring Offset Type
CT19-***A-**-M-**-100 Series**

(See page 44 for other details and dimensions)

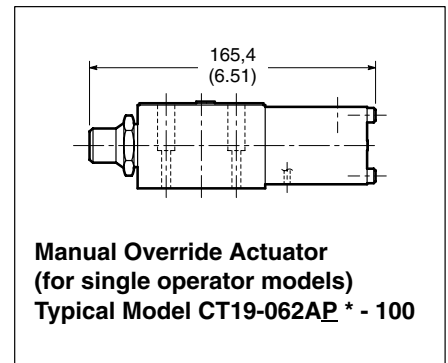
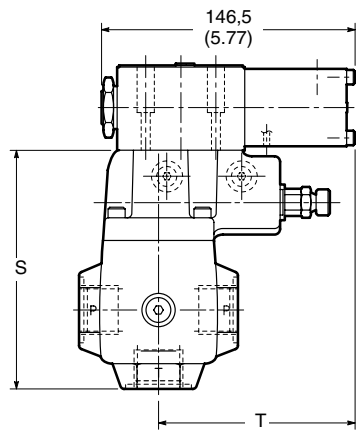
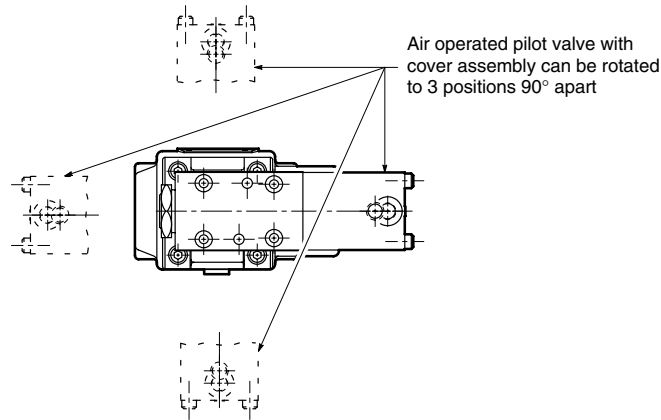

Model	A	B	C	D	E	F	G	H	J
CT19-06	65,0 (2.56)	32,5 (1.28)	194,3 (7.65)	113,3 (4.46)	39,6 (1.56)	55,6 (2.19)	53,8 (2.12)	3/4" NPTF thd.■	76,2 (3.00)
CT19-(H)10	83,3 (3.28)	41,7 (1.64)	205,3 (8.08)	118,1 (4.65)	41,1 (1.62)	62,0 (2.44)	69,9 (2.75)	1 1/4" NPTF thd.■	81,0 (3.19)

Model	K	L	M	N	P	Q	R	S	T
CT19-06	62,0 (2.44)	45,7 (1.80)	4,0 (0.16)	47,8 (1.88)	46,0 (1.81)	95,5 (3.76)	79,4 (3.12)	144,5 (5.69)	106,0 (4.17)
CT19-(H)10	66,5 (2.62)	62,0 (2.44)	5,59 (0.22)	62,0 (2.44)	48,5 (1.91)	124,0 (4.88)	77,7 (3.06)	155,5 (6.12)	108,0 (4.25)

■ Not recommended

Series C*19-06/10 Air Operated Relief Valves

Graphical Symbols

Model C*19-(H)0C (DG18V-3-0C Pilot)**

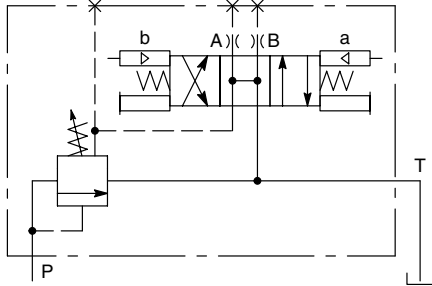

When operator "A" is pressurized, control is at connection "A". When operator "B" is pressurized, control is at connection "B". When both operators are de-pressurized, valve is vented.

Model C*19-(H)2C (DG18V-3-2C Pilot)**

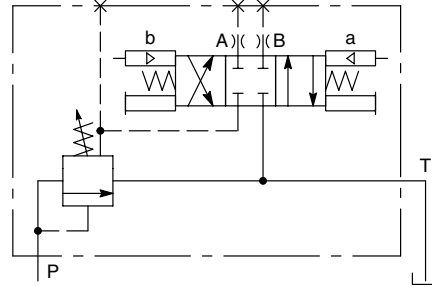

When operator "A" is pressurized, control is at connection "A". When operator "B" is pressurized, control is at connection "B". When both operators are de-pressurized, control is by integral adjustment.

Model C*19-(H)0A (DG18V-3-0BL Pilot)**

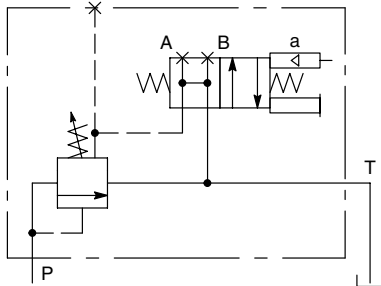

When operator "A" is pressurized, control is by integral adjustment. When operator "A" is de-pressurized, valve is vented.

Model C*19-(H)1A (DG18V-3-2AL Pilot)**

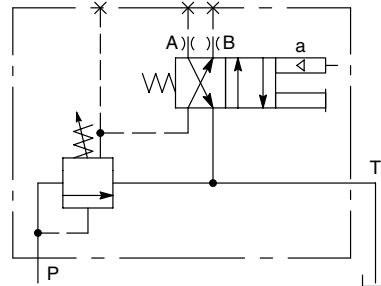

When operator "A" is pressurized, control is at connection "A". When operator "A" is de-pressurized, control is at connection "B".

Model C*19-(H)2A (DG18V-3-2BL Pilot)**

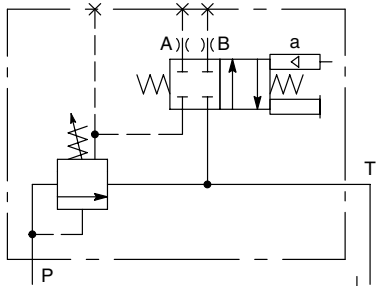

When operator "A" is pressurized, control is at connection "A". When operator "A" is de-pressurized, control is by integral adjustment.

Model C*19-(H)0E (DG18V-3-0FL Pilot)**

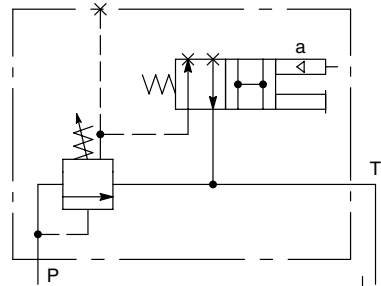

When operator "A" is pressurized, valve is vented. When operator "A" is de-pressurized, control is by integral adjustment.

Series C*-06/10-DG Bi/Tri-Pressure Relief Valves

Model Code

(F3) C G - (H) 10 - C (E) F (V) - (PA3) - DG (L) (W) - 8C - (230AC) - 20

1 2 3 4 5 6 7 8 9 10 11 12 13 14 15 16

1 Seals

F3 – For mineral oil and fire resistant fluids. Mounting face seals of CG model relief and all pilot valves have standard Buna-N seals unless specified as F3.
Blank – Omit for standard models

2 Valve Type

C – Relief valve

3 Connections

G – Manifold or subplate mounting
S – SAE straight thread
T – NPTF thread*

*Not recommended

4 High-flow Designation

H – High-flow valve (not available in CT models)
Blank – Omit if not required

5 Valve Size

06 – 1.0625-12 UN-2B straight thread (0.750 tubing) or 3/4" pipe
10 – 1.6250-12 UN-2B straight thread (1.250 tubing) or 1 1/4" pipe (not available in CS or CT models)

6 Head No. 1 Pressure range

B – 8,5 to 70 bar (125 to 1000 psi)
C – 35 to 140 bar (500 to 2000 psi)
F – 100 to 210 bar (1500 to 3000 psi)
E – Vent (tri-pressure models only)

7 Head No. 2 Pressure Range

B – 8,5 to 70 bar (125 to 1000 psi)
C – 35 to 140 bar (500 to 2000 psi)
F – 100 to 210 bar (1500 to 3000 psi)
E – Vent (tri-pressure models only)
Blank – Omit for bi-pressure models

8 Head No. 3 Pressure Range

B – 8,5 to 70 bar (125 to 1000 psi)
C – 35 to 140 bar (500 to 2000 psi)
F – 100 to 210 bar (1500 to 3000 psi)
E – Vent (tri-pressure models only)

9 High Vent Spring

V – Optional high vent spring installed (required in high-flow models)
Blank – Omit if not required

10 Electrical Connections

PA3 – 3-pin receptacle (single solenoid models only)
PA5 – 5-pin receptacle
PB – "Insta-Plug" with male and female connectors
S – Spool indicator switch (bi-pressure models only). Also available with PA3 and PA5 models.
Blank – Omit if not required

11 Pilot Valve (DG4S4-01)

DG – Solenoid operated, sliding spool, four-way directional valve

12 Solenoid Indicator Light(s)

L – Lights available for use with 100V AC through 125V AC solenoids only
Blank – Omit if not required

13 Housing

W – 1/2" NPT thread wiring housing (required for PA3 and PA5 models)
Blank – Omit if not required

14 Pilot Spool Function and Spring Arrangement

0A – Spring offset open center spool (bi-pressure models only)
8C – Spring centered tandem center spool with open center crossover (tri-pressure models only)



WARNING

Tandem center spool (8) must be used only with spring centered pilot valve (C). Open center spool (0) must be used only with spring offset pilot valve (A). Use of any other spools could be hazardous.

15 Solenoid Coil Voltage Rating

230AC – 230V AC 60 Hz coils
460AC – 460V AC 60 Hz coils
115AC-50/60 – 115V AC 50/60 Hz coils
6DC – 6V DC coils
12DC – 12V DC coils
24DC – 24V DC coils
Blank – Omit for standard 115V AC 60 Hz coils

16 Design Number

Subject to change. Installation dimensions same for designs 20 through 29 (using -50 design DG4S4-01 pilot valve).

Series C*-06/10-DG Bi/Tri-Pressure Relief Valves

General Data

The tri-pressure relief valve is a pressure control unit which can be used to electrically select any one of three preset pressures, or two pressures and vent. The bi-pressure relief valve can be used to electrically select either of two preset pressures, or one pressure and vent.

The main stage is a balanced piston type relief valve, and the intermediate stages are of the poppet spring type. The pilot stage uses a standard DG4S4-01 (NFPA-D05) valve (see Vickers publication 671 for more details).

Pressure Adjustment

Any head in the intermediate stage can contain a B, C, or F spring. The pressure ranges of these springs are shown in the following table.

Spring	Pressure Range bar (psi)
B	8,5 to 70 (125 to 1000)
C	35 to 140 (500 to 2000)
F	100 to 210 (1500 to 3000)

The minimum pressure as indicated for the "B" spring is a function of flow and is shown on the corresponding Nominal Override Characteristics curves.

If there is an "E" in the model code, the corresponding control head contains no spring. When that head is put into operation, the system is vented. The vent pressure is shown on the Vent Pressure vs. Flow curves.

Pressure for each head can be adjusted by loosening a jam nut and turning an adjustment screw. Turning clockwise increases pressure, and turning counterclockwise decreases pressure.

Application Guidance High Flow Valve ("H" Model)

"H" series valves require the use of a high vent spring (CS-H06-BCV-DG or CG-H10-FCBV-DG).

Installation Data

Tank Connection

The tank connection should be piped directly to tank to minimize back pressure. Any back pressure in the tank line is additive to the valve pressure setting. If tank line back pressure exceeds system pressure by 7 bar (100 psi), a malfunction may occur.

Mounting

Inlet and outlet pressure connections (on straight or NPTF thread models) may be used interchangeably when the valve is mounted in the pressure line, or the valve may be teed off the pressure line with one of the pressure connections plugged. The tank connection should be piped directly to tank to minimize back pressure.

Electrical Information

Solenoids

Solenoids on models listed are for 115V AC 60 Hz service. Solenoids for other voltages and frequencies are available. Specify in the model code if service other than 115V AC 60 Hz is desired.

Note

Solenoids are designed to function continuously at $\pm 10\%$ rated voltage.

All solenoid coil wire insulation is Class "F". Standard solenoid coil lead wire has Class "A" insulation. "F3" solenoid coil lead wire is Class "F".

Solenoids "a" and "b" are identified on the unit by a diagram plate on the side of the pilot valve.

Solenoid Energizing

On tri-pressure models (C*-06/10-****-**DG*-**8C**-*-2*), energizing solenoid "a" causes pilot head No. 3 to control the pressure. Energizing solenoid "b" causes pilot head No. 1 to control the pressure. With both solenoids de-energized, pilot head No. 2 will control the pressure.

Solenoids must be kept energized to maintain a desired action.

On bi-pressure models (C*-06/10-***-**DG*-**0A**-*-2*), de-energizing the solenoid causes pilot head No. 1 to control the pressure. Energizing the solenoid causes pilot head No. 3 to control the pressure. The solenoid must be kept energized to maintain the desired action.



WARNING

DG pilot valve must conform to relief valve type being used. If relief valve is tri-pressure, pilot stage must be DG4S4-01**8C**-*-5*. This valve contains type "8" tandem center open center crossover spool. If relief valve is bi-pressure, pilot stage must be DG4S4-01**0A**-*-5*. This valve contains type "0" open center spool. Use of incorrect spools could be hazardous.

Note

Any sliding spool valve, if held shifted under pressure for long periods of time, may stick and not spring return due to fluid residue formation. The valve should be cycled periodically to prevent this.

Spring centered and spring offset pilot valves are spring positioned unless the solenoid is energized continuously.

Additional Information

Eaton publication 671 contains additional information and dimensions on the pilot portion of the C*-06/10-DG, including solenoids and connections, insta-plug connections, and NFPA electrical connectors.

Subplates and Bolt Kits

Valves, subplates, and mounting bolts must be ordered separately.

Example:

- (1) CG-06-BCF-DG-8C-2* valve
- (1) CGM-06S-20 subplate
- (1) BKCG06604 bolt kit (consisting of four bolts, $\frac{5}{8}$ -11 x 2.75")

CGM-06S-20 and CGM-10S-20 subplate installation dimensions are shown in CG-06/10 section. When a subplate is not used, a machined pad (as indicated by subplate shaded area on pages 24 and 25) must be provided for mounting. The pad must be flat within 0,013 mm (0.0005 in) and smooth within 1,6 μ m (63 microinch). Mounting bolts provided by the customer should be SAE grade 7 or better.

Solenoid Voltage Rating	Inrush amps (R.M.S.)	Holding amps	Holding watts
115V AC 60 Hz	5.1	0.61	—
230V AC 60 Hz	2.55	0.32	—
460V AC 60 Hz	1.27	0.16	—
115V AC 50/60 Hz	50 Hz: 3.25 60 Hz: 4.97	50 Hz: 0.56 60 Hz: 0.59	—
6V DC	—	4.0	24
12V DC	—	2.0	24
24V DC	—	1.0	24

Ratings

Rated Pressure (Maximum)	210 bar (3000 psi)	
Rated Capacity (Maximum)	Standard	"H"
C*-06 and CG/S-H06	227 l/min (60 USgpm)	340 l/min (90 USgpm)
CG-10 and CG-H10	454 l/min (120 USgpm)	680 l/min (180 USgpm)

Graphical Symbols

Tri-pressure Spring Centered Valve, 3-position
C*-*-*-DG-8C-2*

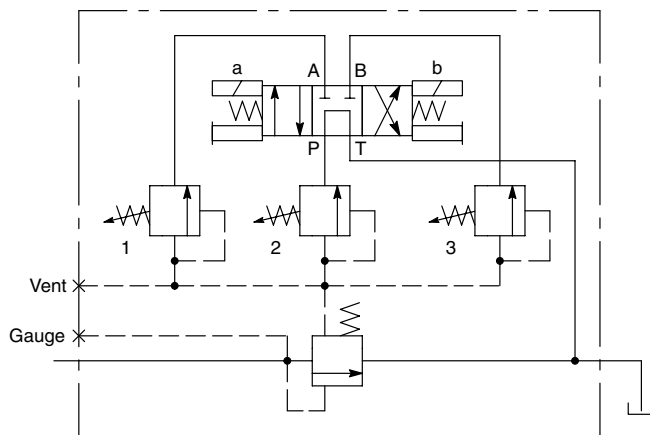

Bi-pressure Spring Offset Valve, 2-position
C*-*-*-DG-0A-2*

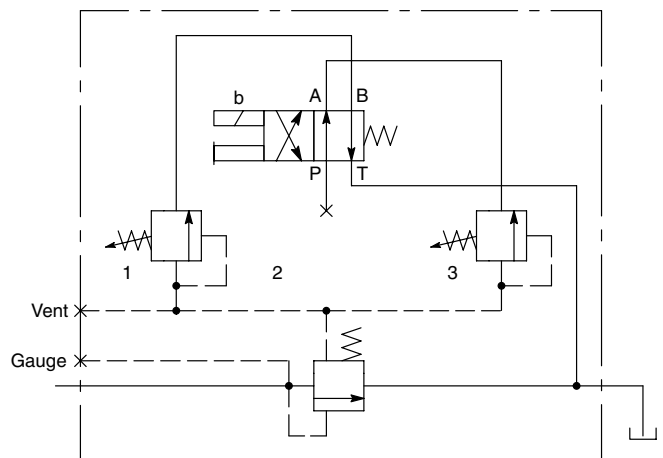

Series C*-06/10-DG Bi/Tri-Pressure Relief Valves

Graphical Symbols (continued)

Internal Vent Tri-pressure Models

On internal vent models, one control head is open and is identified by the letter "E" in the model code. Venting can be set so as to be selected by solenoid "a" or solenoid "b". When control head No. 2 is open, venting takes place when both solenoids are de-energized.

Note

Only the tri-pressure models are recommended for internal venting. If a single solenoid pilot valve is required to select one pressure or vent, consider using a C*5-06/10 model (see page 28).

Tri-pressure Spring Centered Valve, 3-position C*-**-E**-DG-8C-2*

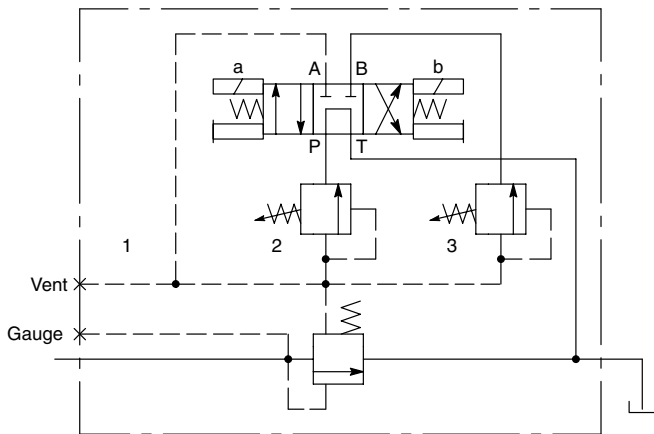

Tri-pressure Spring Centered Valve, 3-position C*-**-E**-DG-8C-2*

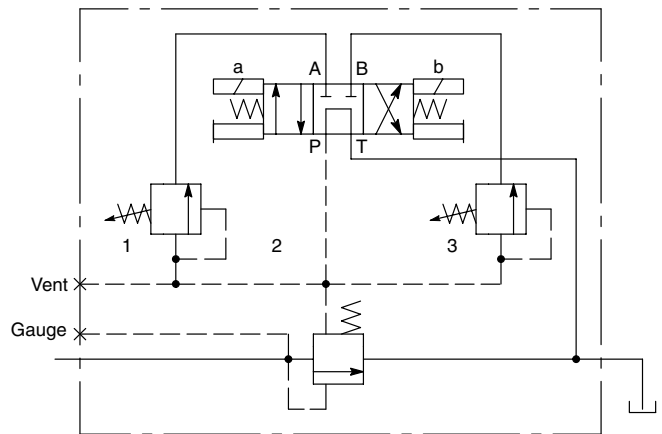

Tri-pressure Spring Centered Valve, 3-position C*-**-E**-DG-8C-2*

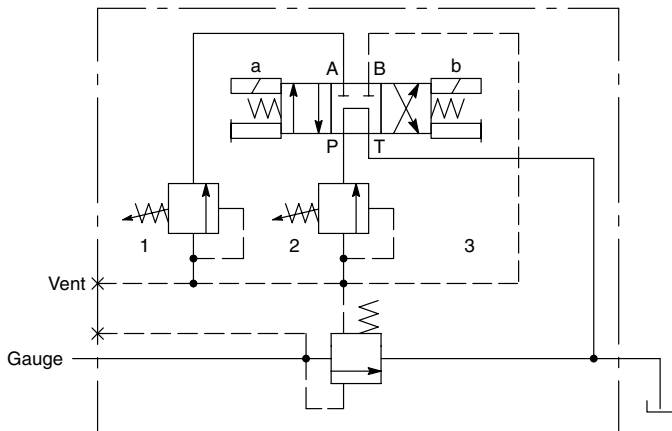

Performance Curves

Nominal Override Characteristics

- C*-06
- ▲ C*-10

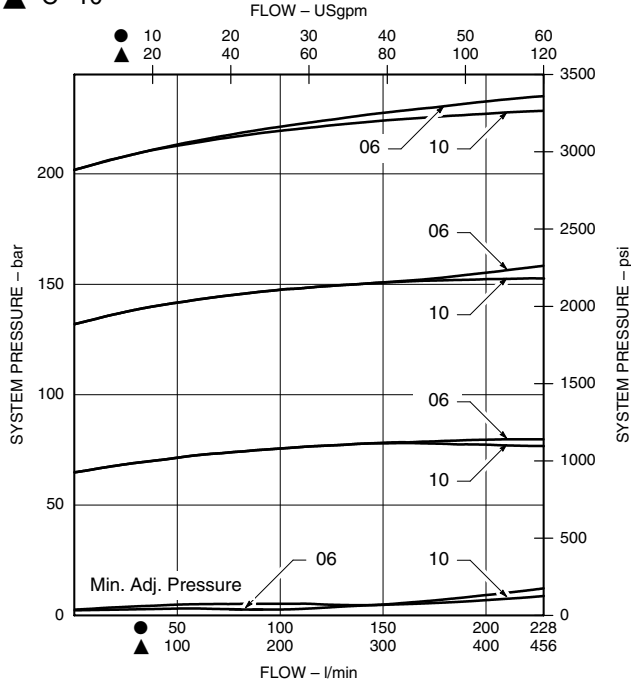

- ◆ C*-H06
- C*-H10

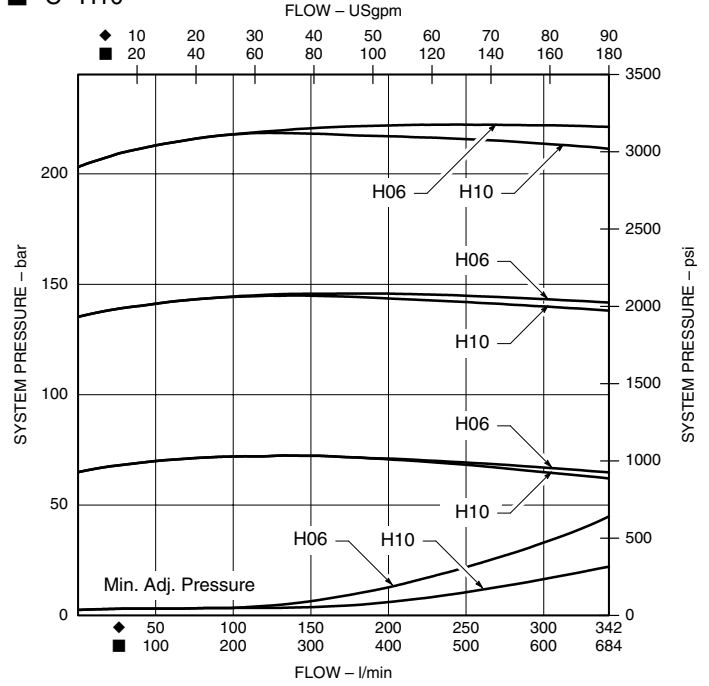

Vent Pressure Versus Flow

- C*-06
- ▲ C*-10

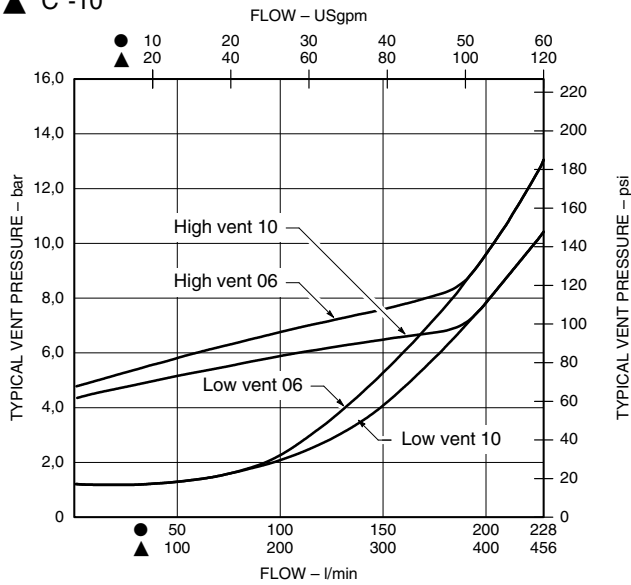

- ◆ C*-H06
- C*-H10

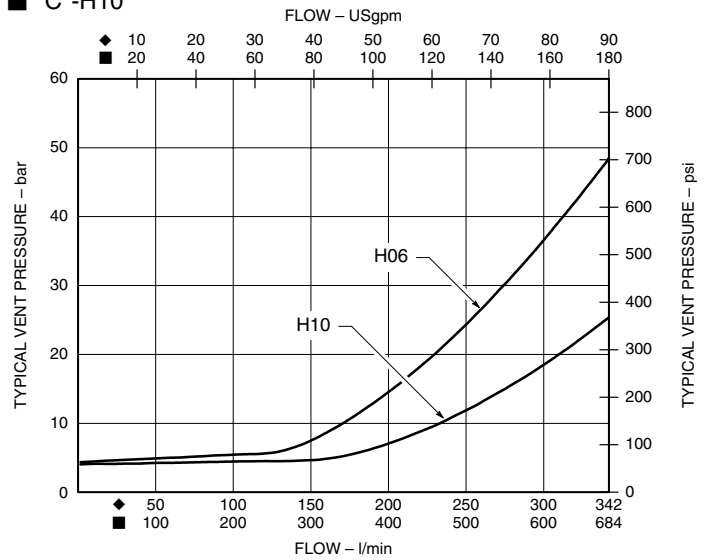

Series C*-06/10-DG Bi/Tri-Pressure Relief Valves

Installation Dimensions

mm (inch)

Subplate or Manifold Mounted Models

Bi-pressure

CG-(H)**-**-***DG*-0A*-2*

and Tri-pressure

CG-(H)**-**-***DG*-8C*-2*

Note

* See mounting subplates for locating dimensions.

** Use 7,92 (0.312) hex key.

† Clearance for removal of solenoid coil.

†† .4375-20 UNF-2B straight thread for 0.250 O.D. tubing.

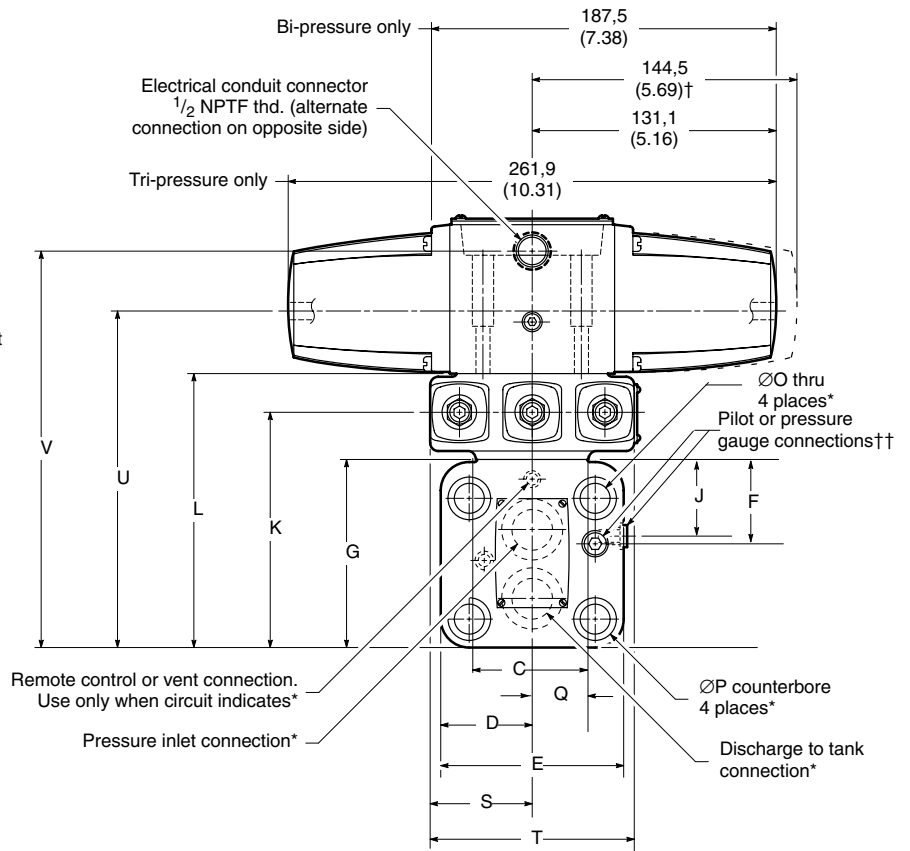
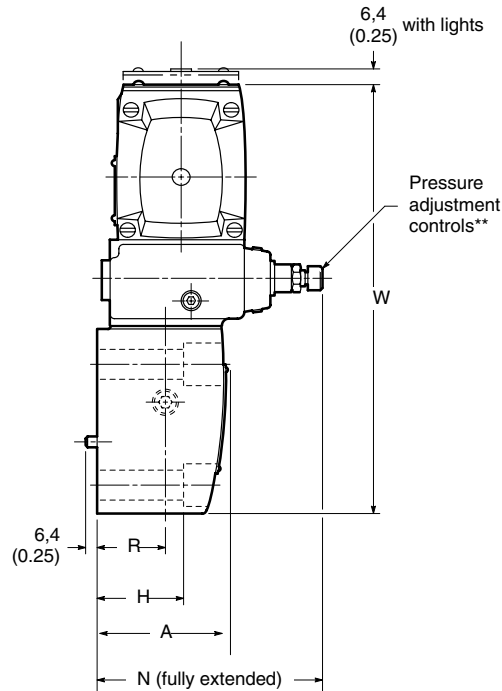
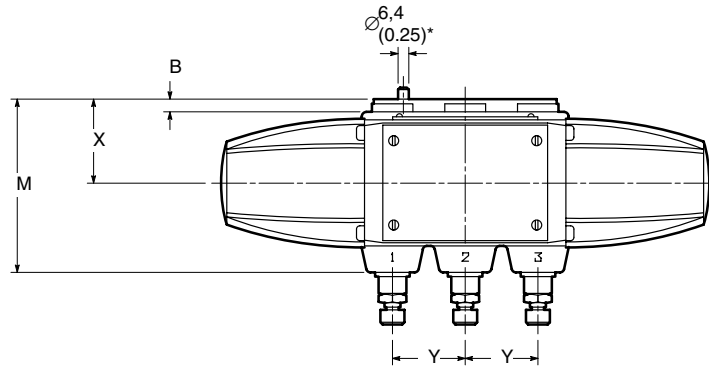

Model	A	B	C	D	E	F	G	H	J	K	L	M	N
CG-(H)06-DG	71,4 (2.81)	7,9 (0.31)	62,0 (2.44)	53,3 (2.10)	106,4 (4.19)	47,8 (1.88)	107,2 (4.22)	47,8 (1.88)	42,9 (1.69)	134,1 (5.28)	155,7 (6.13)	96,8 (3.81)	159,5 (6.28)
CG-(H)10-DG	85,9 (2.81)	2,3 (0.31)	81,0 (2.44)	66,8 (2.63)	133,4 (5.25)	55,6 (2.19)	116,1 (4.57)	63,5 (2.50)	50,8 (2.00)	145,5 (5.73)	166,9 (6.57)	103,1 (4.06)	133,9 (5.27)

Model	O	P	Q	R	S	T	U	V	W	X	Y
CG-(H)06-DG	16,6 (0.65)	24,5 (0.96)	35,1 (1.38)	35,9 (1.53)	55,6 (2.19)	111,3 (4.38)	191,8 (7.55)	225,6 (8.88)	242,8 (9.56)	48,5 (1.91)	39,6 (1.56)
CG-(H)10-DG	19,8 (0.78)	29,3 (1.15)	46,0 (1.81)	42,9 (1.69)	62,7 (2.47)	125,5 (4.94)	202,9 (7.99)	236,7 (9.32)	254,0 (10.00)	60,5 (2.38)	46,7 (1.84)

Threaded Port Models

mm (inch)

Bi-pressure

CS/T-(H)06-**-***DG*-0A-*-2*

and Tri-pressure

CS/T-(H)06-**-***DG*-8C-*-2*

Note

* .7500-16 UNF-2B thread for 0.500 O.D. tubing.

** .4375-20 UNF-2B straight thread for 0.250 O.D. tubing.

† Use 7,92 (0.312) hex key.

†† Clearance for removal of solenoid coil.

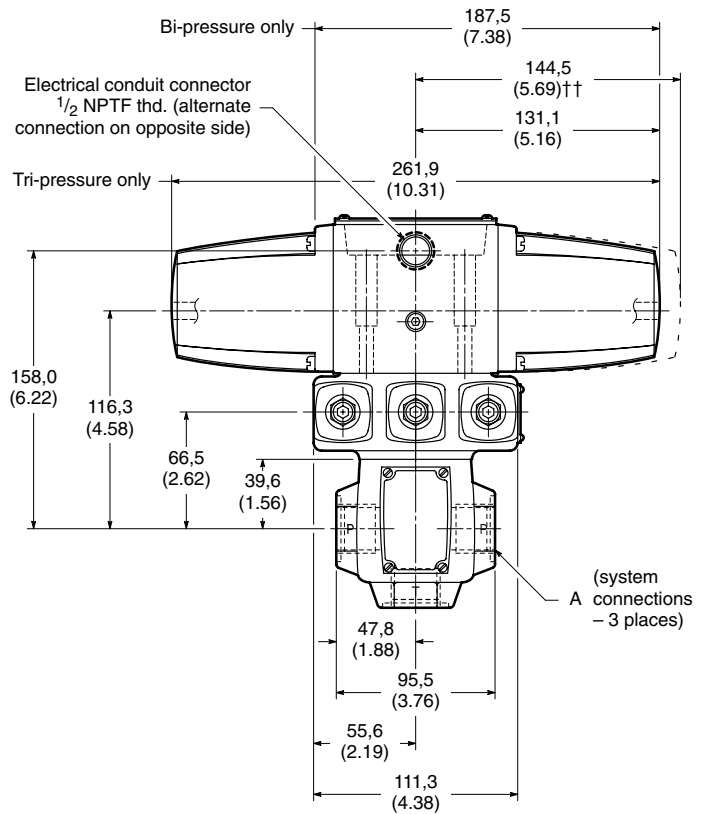
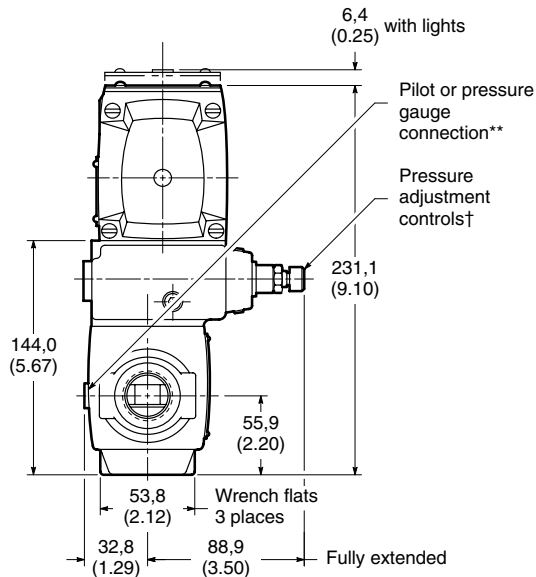
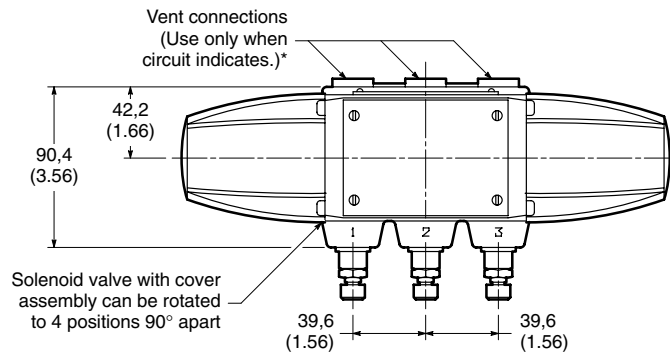

Model	A
CS-(H)06-DG	1.0625-12 UN-2B thd. for 0.750 O.D. tubing
CT-(H)06-DG	3/4" NPTF thd. ■

■ Not recommended

Series C*-06/10-DG Bi/Tri-Pressure Relief Valves

DC Solenoid Models

mm (inch)

Double Solenoid Spring Centered Tri-pressure
C * -(H)06 - * * * - * * * DG-8C-24DC-20

Single Solenoid Spring Offset Bi-pressure
C * -(H)06 - * * - * * * DG-0A-24DC-20

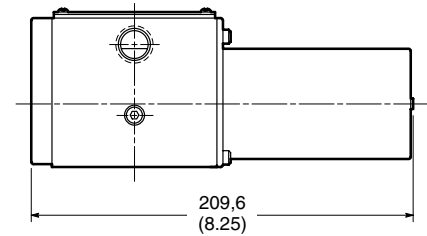
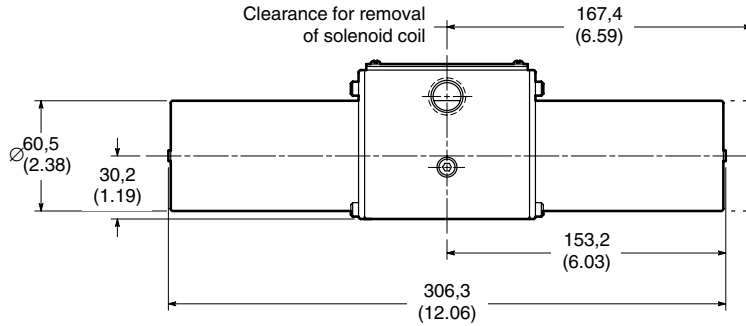

Monitor Switch Models

mm (inch)

Single Solenoid Spring Offset Bi-pressure (only) with Monitor Switch
C * -10- * * -SDG-0A-20

When the solenoid is de-energized, the spool is returned to the offset position.

Internal Monitor Switch

This switch permits electrical interlocking of various hydraulic controlled motions without resorting to external mechanical contrivances. The switch monitors valve spool position and may be wired into the control circuit.

The monitor switch is a plunger type with panel mounting and uses a single pole, double throw contact arrangement. "A" is normally closed, and "B" is normally open.

The housing of the monitor switch does not provide for manual override operation.

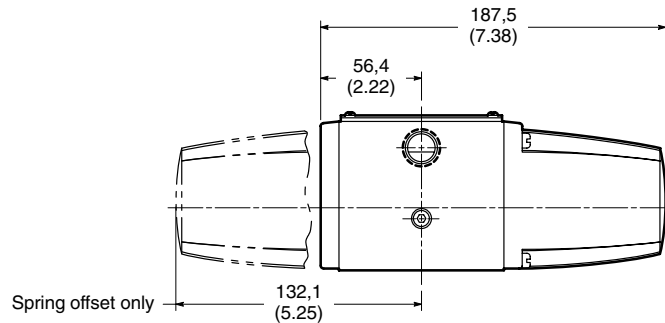

Electrical Ratings

Volts	AC amps	DC amps
28	20	10
125	20	0.5
250	20	0.2
480	20	—
600	5	—

Series C*-06/10-DG-M-M Bi/Tri-Pressure Relief Valves

Model Code

(F3) C G - (H) 10 - F (E) C (V) - DG - 8C (P) - M (S1) (PA5) - M - WL - B(9) - P08 - 50

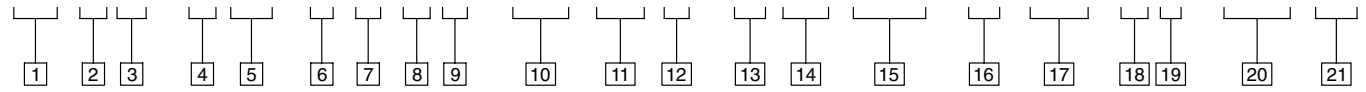

1 Seals

F3 – For mineral oil and fire resistant fluids. Mounting face seals of CG model relief and all pilot valves have standard Buna-N seals unless specified as F3.

Blank – Omit for standard models

2 Valve Type

C – Relief valve

3 Connections

G – Manifold or subplate mounting

S – SAE straight thread

T – NPTF thread*

*Not recommended

4 High-flow Designation

H – High-flow valve (not available in CT models)

Blank – Omit if not required

5 Valve Size

06 – 1.0625-12 UN-2B straight thread (0.750 tubing) or 3/4" pipe

10 – 1.6250-12 UN-2B straight thread (1.250 tubing) or 1 1/4" pipe (not available in CS or CT models)

6 Head No. 1 Pressure Range

B – 8,5 to 70 bar (125 to 1000 psi)

C – 35 to 140 bar (500 to 2000 psi)

F – 100 to 210 bar (1500 to 3000 psi)

E – Vent (tri-pressure models only)

7 Head No. 2 Pressure Range

B – 8,5 to 70 bar (125 to 1000 psi)

C – 35 to 140 bar (500 to 2000 psi)

F – 100 to 210 bar (1500 to 3000 psi)

E – Vent (tri-pressure models only)

Blank – Omit for bi-pressure models

8 Head No. 3 Pressure Range

B – 8,5 to 70 bar (125 to 1000 psi)

C – 35 to 140 bar (500 to 2000 psi)

F – 100 to 210 bar (1500 to 3000 psi)

E – Vent (tri-pressure models only)

9 High Vent Spring

V – Optional high vent spring installed (required in high-flow models)

Blank – Omit if not required

10 Pilot Valve (DG4V-3 or DG4V-3S)

DG – Solenoid operated, sliding spool, four-way directional valve

11 Pilot Spool Function and Spring Arrangement

0A – Spring offset open center spool (bi-pressure models only)

8C – Spring centered tandem center spool with open center crossover (tri-pressure models only)



WARNING

Tandem center spool (8) must be used only with spring centered pilot valve (C). Open center spool (0) must be used only with spring offset pilot valve (A). Use of any other spools could be hazardous.

12 Manual Override

P – Plain override in both ends of single solenoid (bi-pressure models only)

Blank – Omit if not required

13 Flag Symbol

M – Electrical options and features

14 Spool Indicator Switch

For spring offset (A) models only. Not available in manual override models.

S – Switch unwired

S1 – Switch wired normally open

S2 – Switch wired normally closed

Blank – Omit if not required

15 Electrical Connections

PA3 – 3-pin receptacle (single solenoid models only)

PA5 – 5-pin receptacle

PB – "Insta-Plug" with male and female connectors

Blank – Omit if not required

16 Pilot and Adapter

M – DG4V-3(S) pilot valve with adapter plate*

*Refer to catalog GB-C-2015 for pilot and adapter plate mounting information.

17 Housing or Coil Type

(W or WL required for PA3 and PA5 models)

U – ISO 4400 (DIN 43650) connector

W – 1/2" NPT thread wiring housing

WL – 1/2" NPT thread wiring housing with coil indicator lights

18 Solenoid Coil Voltage Rating

A – 110V AC 50 Hz

B – 110V AC 50 Hz/120V AC 60 Hz

C – 220V AC 50 Hz

D – 220V AC 50 Hz/240V AC 60 Hz

G – 12V DC

H – 24V DC

19 Coil Wattage

9 – Low wattage coil*

Blank – Omit if not required

* Available only with B, G, and H voltage coils and only on -40 design models.

20 Pilot Valve Port Orifices

***00** – Solid plug

***03** – 0,30 (0.012)

***06** – 0,60 (0.024)

***08** – 0,80 (0.030)

***10** – 1,00 (0.040)

***13** – 1,30 (0.050)

***15** – 1,50 (0.060)

***20** – 2,00 (0.080)

***23** – 2,30 (0.090)

Blank – Omit if not required

* = P, T, A, or B as required

21 Design Number

40 – Model with DG4V-3S standard performance pilot valve

50 – Model with DG4V-3 high performance pilot valve

Subject to change. Installation dimensions same for designs 40 through 49 and for designs 50 through 59.

Series C*-06/10-DG-M-M Bi/Tri-Pressure Relief Valves

General Data

The -40 and -50 design multi-pressure solenoid operated relief valves are the same as the -20 design shown in the previous section, except for the pilot valve. The DG4S4-10 (NFPA-D05) pilot valve used in the -20 design is replaced by a smaller DG4V3 (NFPA-D03) valve. The -40 design uses a DG4V-3S (standard performance) pilot valve, and the -50 design uses a DG4V-3 (high performance) pilot valve.

Pressure relief performance of the -40 and -50 design valves is the same as for the -20 design valve, but pilot pressures as high as 350 bar (5075 psi) are possible with the -40 and -50 designs. The -50 design provide greater pilot flow capability.

The tri-pressure relief valve is a pressure control unit which can be used to electrically select any one of three preset pressures, or two pressures and vent. The bi-pressure relief valve can be used to electrically select either of two preset pressures, or one pressure and vent.

The main stage is a Vickers balanced piston type relief valve, and the intermediate stages are of the poppet spring type. As explained above, the pilot stage uses either a standard DG4V3S or high performance DG4V3 valve (see Vickers publication GB-C-2015B for more details).

Pressure Adjustment

Any head in the intermediate stage can contain a B, C, or F spring. The pressure ranges of these springs are shown in the following table.

Spring	Pressure Range bar (psi)
B	8,5 to 70 (125 to 1000)
C	35 to 140 (500 to 2000)
F	100 to 210 (1500 to 3000)

The minimum pressure as indicated for the “B” spring is a function of flow and is shown on the corresponding Nominal Override Characteristics curves.

If there is an “E” in the model code, the corresponding control head contains no spring. When that head is put into operation, the system is vented. The vent pressure is shown on the Vent Pressure vs. Flow curves.

Pressure for each head can be adjusted by loosening a jam nut and turning an adjustment screw. Turning clockwise increases pressure, and turning counterclockwise decreases pressure.

Electrical Information

Solenoids

Solenoids “a” and “b” are identified on the unit by a diagram plate on the side of the pilot valve.

Solenoid Energizing

On tri-pressure models (C*-06/10-****-**DG*-**8C**-*-M-M-**-40/50), energizing solenoid “a” causes pilot head No. 3 to control the pressure. Energizing solenoid “b” causes pilot head No. 1 to control the pressure. With both solenoids de-energized, pilot head No. 2 will control the pressure. Solenoids must be kept energized to maintain a desired action.

On bi-pressure models (C*-06/10-****-**DG*-**0A**-*-M-M-**-40/50), de-energizing the solenoid causes pilot head No. 1 to control the pressure. Energizing the solenoid causes pilot head No. 3 to control the pressure. The solenoid must be kept energized to maintain the desired action.



WARNING

DG pilot valve must conform to relief valve type being used. If relief valve is tri-pressure, pilot stage must be DG4V-3(S)-**8C**. This valve contains type “8” tandem center open center crossover spool. If relief valve is bi-pressure, pilot stage must be DG4V-3(S)-**0A**. This valve contains type “0” open center spool. Use of incorrect spools could be hazardous.

Note

Any sliding spool valve, if held shifted under pressure for long periods of time, may stick and not spring return due to fluid residue formation. The valve should be cycled periodically to prevent this.

Spring centered and spring offset pilot valves are spring positioned unless the solenoid is energized continuously.

Application Guidance

High Flow Valve (“H” Model)

“H” series valves require the use of a high vent spring (CS-H06-BCV-DG or CG-H10-FCBV-DG).

Installation Data

Tank Connection

The tank connection should be piped directly to tank to minimize back pressure. Any back pressure in the tank line is additive to the valve pressure setting. If tank line back pressure exceeds system pressure by 7 bar (100 psi), a malfunction may occur.

Mounting

Inlet and outlet pressure connections (on straight or NPTF thread models) may be used interchangeably when the valve is mounted in the pressure line, or the valve may be teed off the pressure line with one of the pressure connections plugged. The tank connection should be piped directly to tank to minimize back pressure.

Subplates and Bolt Kits

Valves, subplates, and mounting bolts must be ordered separately.

Example:

- (1) CG-06-BCF-DG-8C-M-M-**-40 valve
- (1) CGM-06S-20 subplate
- (1) BKCG06604 bolt kit (consisting of four bolts, ⁵/₈-11 x 2.75")

CGM-06S-20 and CGM-10S-20 subplate installation dimensions are shown in CG-06/10 section. When a subplate is not used, a machined pad (as indicated by subplate shaded area on pages 24 and 25) must be provided for mounting. The pad must be flat within 0,013 mm (0.0005 in) and smooth within 1,6 μm (63 microinch). Mounting bolts provided by the customer should be SAE grade 7 or better.

Ratings

Rated Pressure (Maximum)	210 bar (3000 psi)	
Rated Pressure (Maximum)	Standard	“H”
C*-06 and CG/S-H06	227 L/min (60 USgpm)	340 L/min (90 USgpm)
CG-10 and CG-H10	454 L/min (120 USgpm)	680 L/min (180 USgpm)

Internal Vent Tri-pressure Models

On internal vent models, one control head is open and is identified by the letter "E" in the model code. Venting can be set so as to be selected by solenoid "a" or solenoid "b". When control head No. 2 is open, venting takes place when both solenoids are de-energized.

Note

Only the tri-pressure models are recommended for internal venting. If a single solenoid pilot valve is required to select one pressure or vent, consider using a C*5-06/10 model (see page 28).

Graphical Symbols

Tri-pressure Spring Centered Valve, 3-position
C*-*-*-*DG-8C-M-M-*-*40/50

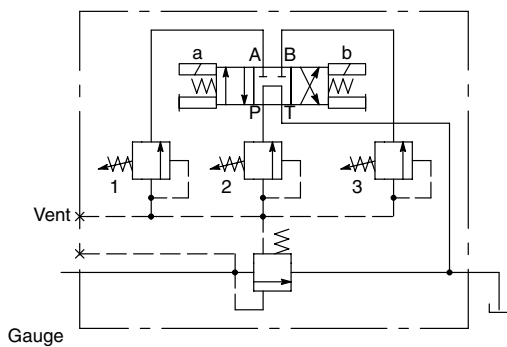

Bi-pressure Spring Offset Valve, 2-position
C*-*-*-*DG-0A-M-M-*-*40/50

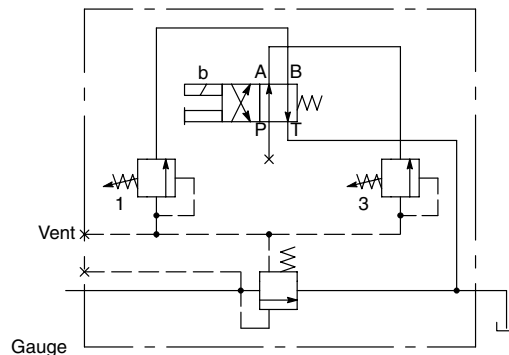

Tri-pressure Spring Centered Valve, 3-position
C*-*-*E**DG-8C-M-M-*-*40/50

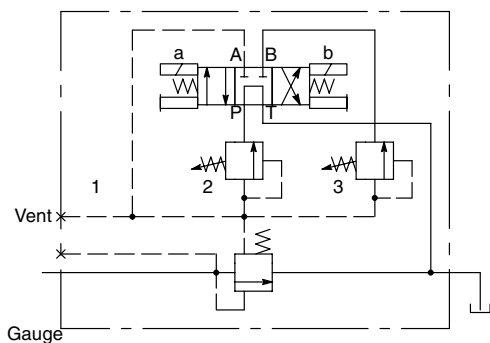

Tri-pressure Spring Centered Valve, 3-position
C*-*-*E*-DG-8C-M-M-*-*40/50

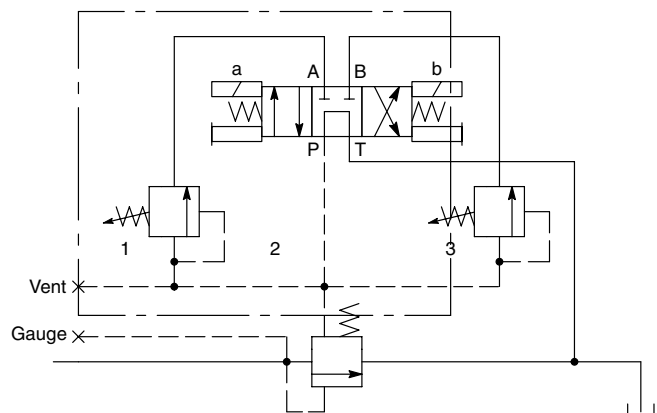

Tri-pressure Spring Centered Valve, 3-position
C*-*-*E-DG-8C-M-M-*-*40/50

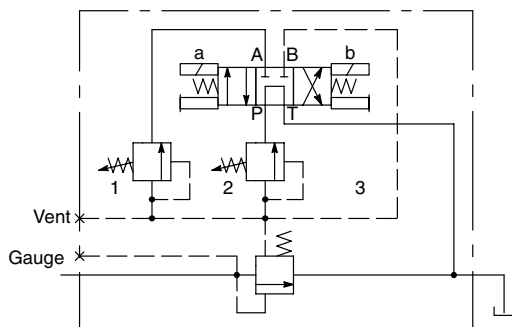

Series C*-06/10-DG-M-M Bi/Tri-Pressure Relief Valves

Performance Curves

Nominal Override Characteristics

- C*-06
- ▲ C*-10

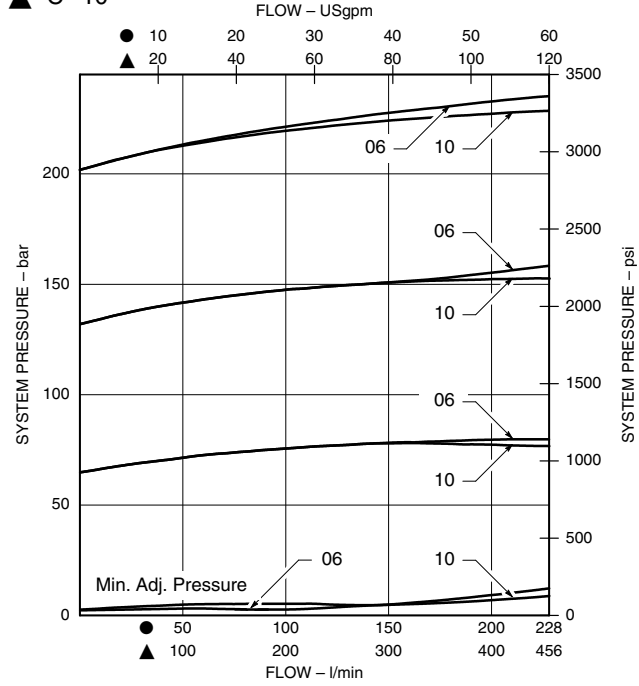

- ◆ C*-H06
- C*-H10

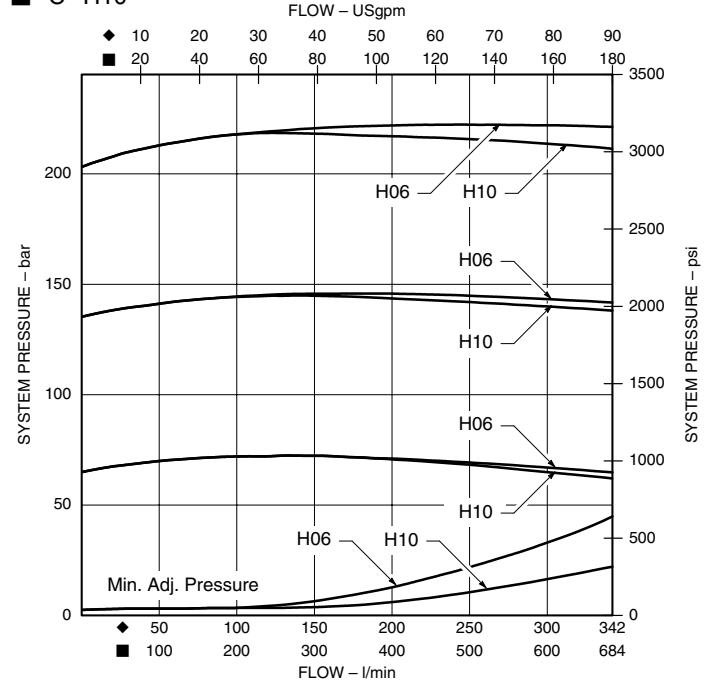

Vent Pressure Versus Flow

- C*-06
- ▲ C*-10

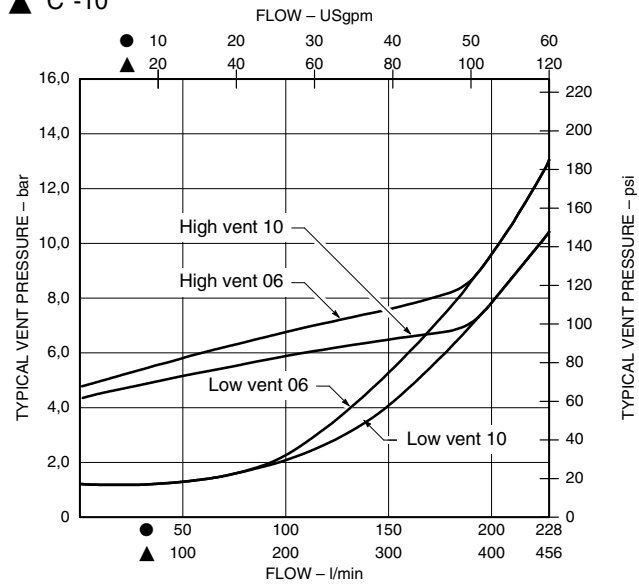

- ◆ C*-H06
- C*-H10

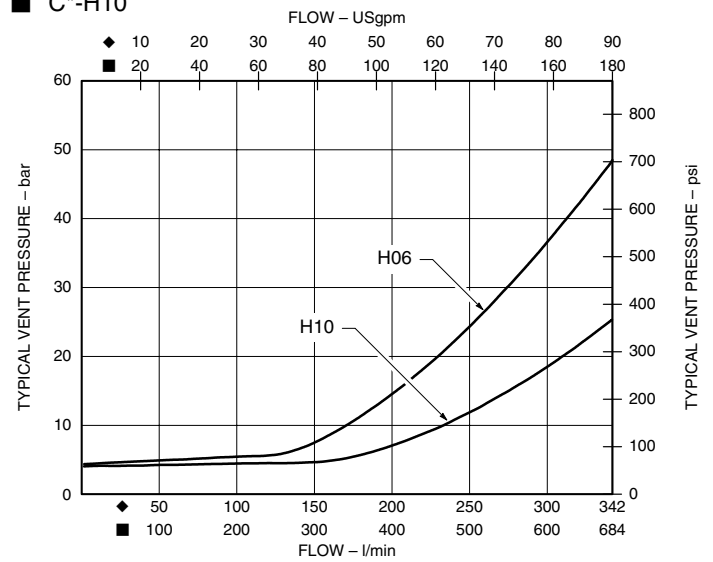

Installation Dimensions

mm (inch)

Subplate or Manifold Mounted Models

Bi-pressure CG-(H)-**DG-0A-M-M-**-40/50 and**

Tri-pressure CG-(H)-**DG-8C-M-M-**-40/50**

Note

* See mounting subplates (page 24) for locating dimensions.

** Use 7,92 (0.312) hex key.

† Clearance for removal of solenoid coil.

†† .4375-20 UNF-2B straight thread for 0.250 O.D. tubing.

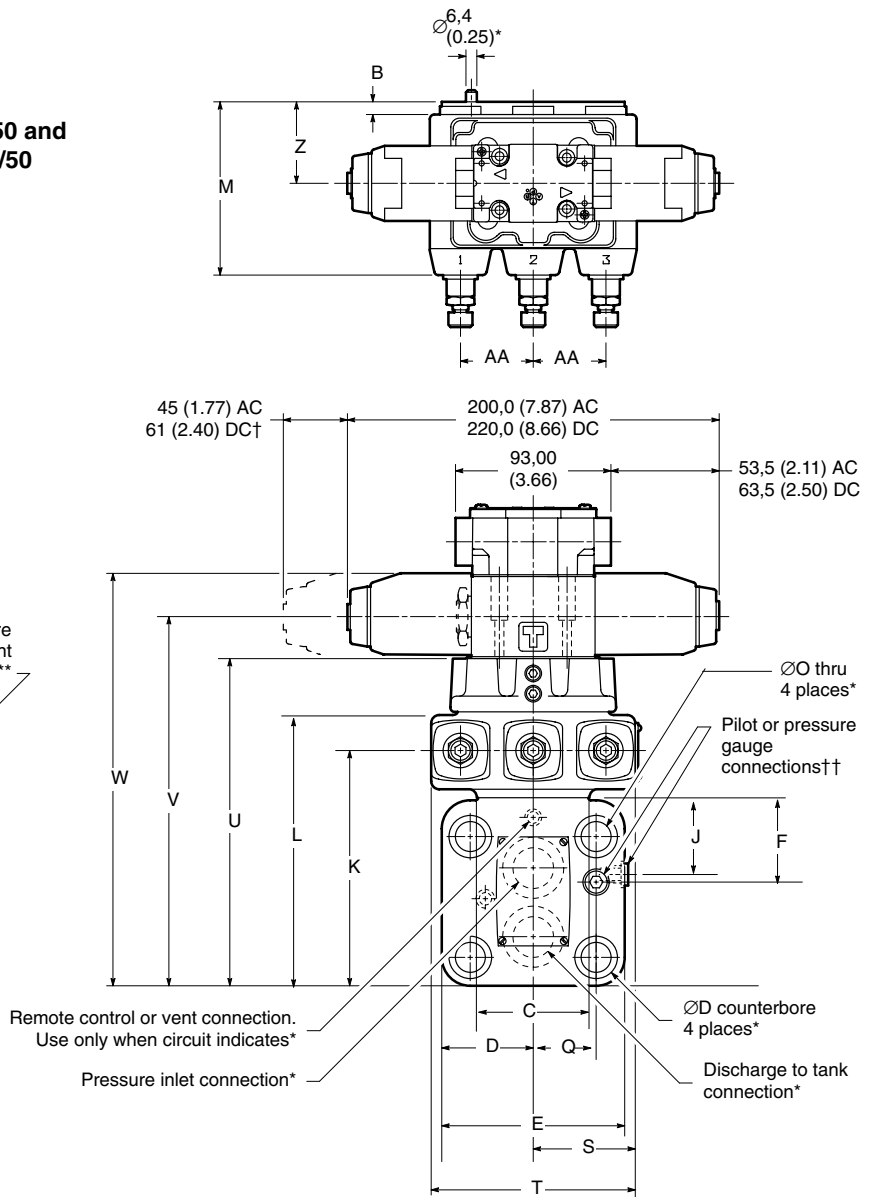
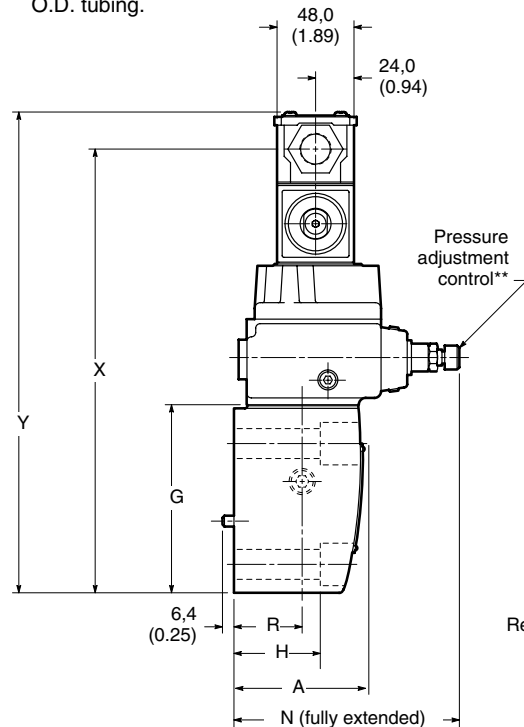

Model	A	B	C	D	E	F	G	H	J	K	L	M	N
CG-(H)06-DG	71,4 (2.81)	7,9 (0.31)	62,0 (2.44)	53,3 (2.10)	106,4 (4.19)	47,8 (1.88)	107,2 (4.22)	47,8 (1.88)	42,9 (1.69)	131,1 (5.16)	156,5 (6.16)	100,8 (3.97)	159,5 (6.28)
CG-(H)10-DG	85,9 (3.38)	2,3 (0.31)	81,0 (2.44)	66,8 (2.63)	133,4 (5.25)	55,6 (2.19)	116,1 (4.57)	63,5 (2.50)	50,8 (2.00)	141,5 (5.57)	164,6 (6.48)	104,7 (4.12)	163,6 (6.44)

Model	O	P	Q	R	S	T	U	V	W	X	Y	Z	AA
CG-(H)06-DG	16,6 (1.38)	24,5 (0.96)	35,1 (1.38)	35,9 (1.53)	55,6 (2.19)	111,3 (4.38)	184,9 (7.28)	209,8 (8.26)	235,7 (9.28)	253,5 (9.98)	275,6 (10.85)	48,5 (1.91)	39,6 (1.56)
CG-(H)10-DG	19,8 (0.78)	29,3 (1.15)	46,0 (1.81)	42,9 (1.69)	62,7 (2.47)	125,5 (4.94)	196,1 (7.72)	221,0 (8.70)	246,9 (9.72)	264,4 (10.41)	286,8 (11.29)	60,5 (2.38)	46,7 (1.84)

Series C*-06/10-DG-M-M Bi/Tri-Pressure Relief Valves

Threaded Port Models

mm (inch)

Bi-pressure

CS/T-(H)06-**DG-0A-M-M-**-40/50

and Tri-pressure

CS/T-(H)06-***DG-8C-M-M-**-40/50

Note

* .7500-16 UNF-2B thread for 0.500 O.D. tubing.

** .4375-20 UNF-2B straight thread for 0.250 O.D. tubing.

† Use 7,92 (0.312) hex key.

†† Clearance for removal of solenoid coil.

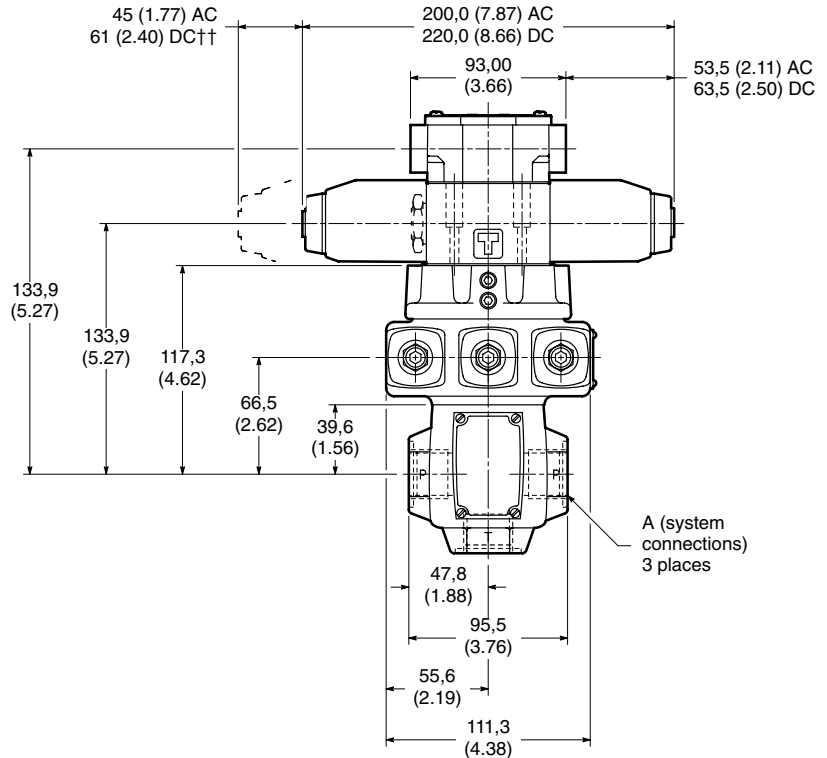
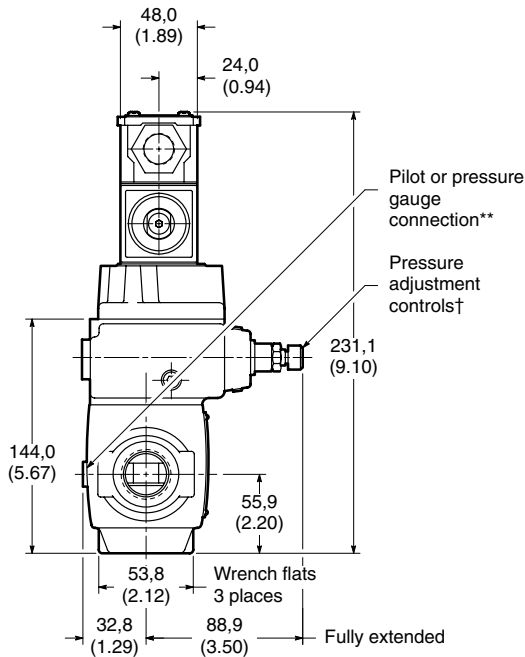
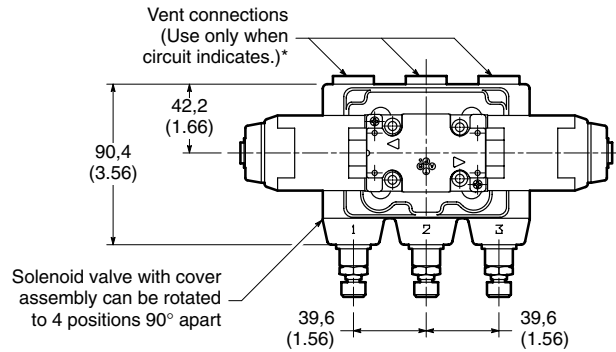

Model	A
CS-(H)06-DG	1.0625-12 UN-2B thd. for 0.750 O.D. tubing
CT-(H)06-DG	3/4" NPTF thd. ■

■ Not recommended

Application Data

Weights

The following table lists the approximate weight of each valve in the catalog:

Valve	Weight kg (lbs)
CGR-02	1,4 (3)
C-175	1,8 (4)
CG-03	3,2 (7)
CS/T-03/06	2,7 (6)
CG-06	5,0 (11)
CG-10	8,6 (19)
CG5-06	8,4 (18.5)
CG5-10	11,1 (24.5)
CS/T-03/06	6,1 (13.5)
CS/T-10	8,6 (19)
CG19-(H)06	7,8 (17.2)
CG19-(H)10	10,5 (23.2)
CT19-06	4,8 (12.9)
CT19-10	7,3 (18.4)
CG-(H)06-DG	11,8 (26)
CG-(H)10-DG	18,1 (40)
CS/T-(H)06-DG	10,0 (22)
CG-(H)06-DG-M-M	11,3 (25)
CG-(H)10-DG-M-M	17,7 (39)
CS/T-(H)06-DG-M-M	10,0 (22)

The following table lists the approximate weight of each subplate in the catalog:

Subplate	Weight kg (lbs)
CGM-10S-03-10	1,6 (3.5)
CGMT-03-10	1,6 (3.5)
CGM-06S-20	3,4 (7.5)
CGM-10S-20	6,8 (15.0)

Fluids and Seals

For best results, oil viscosity should range between 32 cSt and 49 cSt (150 SUS and 225 SUS) at 38°C (100°F). Maximum operating temperature is 66°C (150°F) for the CGR-02 and 68°C (155°F) for all other models. Water glycol, water-in-oil emulsions, and petroleum oil may be used with non-F3 models, which are furnished with Buna-N seals for the mounting surface and fluorocarbon seals internally. Add F3 prefix when phosphate ester type fluids or blends are to be used. All seals of the F3 models are fluorocarbon, including the mounting surface seals.

Subplates and Bolt Kits

Valves, subplates, and mounting bolts must be ordered separately.

Example:

- (1) CG5-062C-F-M-W-*-110 valve
- (1) CGM-06S-20 subplate
- (1) BKCG06604 bolt kit (consisting of four bolts, $\frac{5}{8}$ -11 x 2.75")

The following table lists the appropriate bolt kit for each subplate mounted valve in the catalog:

Valve	Bolt Kit
CG-03-B-10	BKCG03602
CG-(H)06-*(V)-50	BKCG06604
CG-06-*(V)Y-50	BKCG06605
CG-(H)10-*(V)-30	BKCG10616
CG-10-*(V)Y-30	BKCG10616
CG5-06*-110	BKCG06604
CG5-10*-110	BKCG10616
CG19-06*-100	BKCG06604
CG19-10*-100	BKCG10616
CG-(H)06-DG*-20/40/50	BKCG06604
CG-(H)10-DG*-20/40/50	BKCG10616

When a subplate is not used, a machined pad (as indicated by shaded area on subplate installation dimensions pages) must be provided for mounting. The pad must be flat within 0,013 mm (0.0005 in) and smooth within 1,6 μ m (63 microinch). Mounting bolts provided by the customer should be SAE grade 7 or better.

Fluid Cleanliness

Proper fluid condition is essential for long and satisfactory life of hydraulic components and systems. Hydraulic fluid must have the correct balance of cleanliness, materials, and additives for protection against wear of components, elevated viscosity, and inclusion of air.

Essential information on the correct methods for treating hydraulic fluid is included in Vickers publication 561 "Vickers Guide to Systemic Contamination Control" available from your local Vickers distributor or by contacting Vickers, Incorporated. Recommendations on filtration and the selection of products to control fluid condition are included in 561.

The recommended fluid cleanliness level is: **19/17/14**

Алматы (7273)495-231
Ангарск (3955)60-70-56
Архангельск (8182)63-90-72
Астрахань (8512)99-46-04
Барнаул (3852)73-04-60
Белгород (4722)40-23-64
Благовещенск (4162)22-76-07
Брянск (4832)59-03-52
Владивосток (423)249-28-31
Владикавказ (8672)28-90-48
Владимир (4922)49-43-18
Волгоград (844)278-03-48
Вологда (8172)26-41-59
Воронеж (473)204-51-73
Екатеринбург (343)384-55-89

Иваново (4932)77-34-06
Ижевск (3412)26-03-58
Иркутск (395)279-98-46
Казань (843)206-01-48
Калининград (4012)72-03-81
Калуга (4842)92-23-67
Кемерово (3842)65-04-62
Киров (8332)68-02-04
Коломна (4966)23-41-49
Кострома (4942)77-07-48
Краснодар (861)203-40-90
Красноярск (391)204-63-61
Курск (4712)77-13-04
Курган (3522)50-90-47
Липецк (4742)52-20-81

Магнитогорск (3519)55-03-13
Москва (495)268-04-70
Мурманск (8152)59-64-93
Набережные Челны (8552)20-53-41
Нижний Новгород (831)429-08-12
Новокузнецк (3843)20-46-81
Ноябрьск (3496)41-32-12
Новосибирск (383)227-86-73
Омск (3812)21-46-40
Орел (4862)44-53-42
Оренбург (3532)37-68-04
Пенза (8412)22-31-16
Петрозаводск (8142)55-98-37
Псков (8112)59-10-37
Пермь (342)205-81-47

Ростов-на-Дону (863)308-18-15
Рязань (4912)46-61-64
Самара (846)206-03-16
Санкт-Петербург (812)309-46-40
Саратов (845)249-38-78
Севастополь (8692)22-31-93
Саранск (8342)22-96-24
Симферополь (3652)67-13-56
Смоленск (4812)29-41-54
Сочи (862)225-72-31
Ставрополь (8652)20-65-13
Сургут (3462)77-98-35
Сыктывкар (8212)25-95-17
Тамбов (4752)50-40-97
Тверь (4822)63-31-35

Тольятти (8482)63-91-07
Томск (3822)98-41-53
Тула (4872)33-79-87
Тюмень (3452)66-21-18
Ульяновск (8422)24-23-59
Улан-Удэ (3012)59-97-51
Уфа (347)229-48-12
Хабаровск (4212)92-98-04
Чебоксары (8352)28-53-07
Челябинск (351)202-03-61
Череповец (8202)49-02-64
Чита (3022)38-34-83
Якутск (4112)23-90-97
Ярославль (4852)69-52-93

Россия +7(495)268-04-70

Казахстан +7(7172)727-132

Киргизия +996(312)96-26-47

<https://vickers.nt-rt.ru> || vsh@nt-rt.ru