

Алматы (7273)495-231
Ангарск (3955)60-70-56
Архангельск (8182)63-90-72
Астрахань (8512)99-46-04
Барнаул (3852)73-04-60
Белгород (4722)40-23-64
Благовещенск (4162)22-76-07
Брянск (4832)59-03-52
Владивосток (423)249-28-31
Владикавказ (8672)28-90-48
Владимир (4922)49-43-18
Волгоград (844)278-03-48
Вологда (8172)26-41-59
Воронеж (473)204-51-73
Екатеринбург (343)384-55-89

Иваново (4932)77-34-06
Ижевск (3412)26-03-58
Иркутск (395)279-98-46
Казань (843)206-01-48
Калининград (4012)72-03-81
Калуга (4842)92-23-67
Кемерово (3842)65-04-62
Киров (8332)68-02-04
Коломна (4966)23-41-49
Кострома (4942)77-07-48
Краснодар (861)203-40-90
Красноярск (391)204-63-61
Курск (4712)77-13-04
Курган (3522)50-90-47
Липецк (4742)52-20-81

Магнитогорск (3519)55-03-13
Москва (495)268-04-70
Мурманск (8152)59-64-93
Набережные Челны (8552)20-53-41
Нижний Новгород (831)429-08-12
Новокузнецк (3843)20-46-81
Ноябрьск (3496)41-32-12
Новосибирск (383)227-86-73
Омск (3812)21-46-40
Орел (4862)44-53-42
Оренбург (3532)37-68-04
Пенза (8412)22-31-16
Петрозаводск (8142)55-98-37
Псков (8112)59-10-37
Пермь (342)205-81-47

Ростов-на-Дону (863)308-18-15
Рязань (4912)46-61-64
Самара (846)206-03-16
Санкт-Петербург (812)309-46-40
Саратов (845)249-38-78
Севастополь (8692)22-31-93
Саранск (8342)22-96-24
Симферополь (3652)67-13-56
Смоленск (4812)29-41-54
Сочи (862)225-72-31
Ставрополь (8652)20-65-13
Сургут (3462)77-98-35
Сыктывкар (8212)25-95-17
Тамбов (4752)50-40-97
Тверь (4822)63-31-35

Тольятти (8482)63-91-07
Томск (3822)98-41-53
Тула (4872)33-79-87
Тюмень (3452)66-21-18
Ульяновск (8422)24-23-59
Улан-Удэ (3012)59-97-51
Уфа (347)229-48-12
Хабаровск (4212)92-98-04
Чебоксары (8352)28-53-07
Челябинск (351)202-03-61
Череповец (8202)49-02-64
Чита (3022)38-34-83
Якутск (4112)23-90-97
Ярославль (4852)69-52-93

Россия +7(495)268-04-70

Казахстан +7(7172)727-132

Киргизия +996(312)96-26-47

<https://vickers.nt-rt.ru> || vsh@nt-rt.ru

Vickers® Pressure Relief



Sequence, Unloading, Back Pressure,
Counterbalance, and Reducing Valves
“R”, “UR”, and “X” 03/06/10/12 Series
Pressures to 210 bar (3000 psi) – Flows to 284 l/min (75 USgpm)



VICKERS

Released 7/94

686

Introduction

“R” Series Sequence, Unloading, Back Pressure, and Counterbalance Valves

There are several configurations of this basic valve which can be made by changing cover positions. The following outlines each type of function.

Sequence and Unloading

Vickers “Hydrocushion” type pressure control valves are used for the control of unloading and sequence of oil flow in hydraulic systems, induced by a pressure rise, directly or by remote means. They are available in the following types: sequence valve, Type 2—directly operated; sequence valve, Type 3—remotely controlled; unloading valve, Type 4—remotely controlled.

Back Pressure

Back pressure valves are designated as Type 1—internally operated. They are used to provide back pressure on the hydraulic actuator to prevent

overrunning. A remote ‘P’ version is also available for use in braking circuits.

Counterbalance

Vickers “Hydrocushion” type counterbalance valves are used for the control of unloading and sequence of oil flow in hydraulic systems, induced by pressure rise either directly or by remote means. They are available in the following types: counterbalance valve, Type 1—internally operated; counterbalance valve, Type 4—remotely controlled. These valves are usually applied in a system to keep a vertical load from falling. All models provide free reverse flow by means of an integral check valve. (Refer to valves without integral check when reverse free flow is not required.)

“UR” Series Unloading Relief Valves with Integral Check Module

An integral check valve prevents return flow from the accumulator through the unloading valve. In an accumulator

system, the valve cuts out automatically when the accumulator pressure reaches adjusted maximum. At cut-in pressure (approximately 85% of adjusted maximum), the valve directs delivery to the accumulator and the hydraulic system automatically.

In a double pump system, the valve automatically sequences the pumps to deliver a large volume of oil at low pressure and a small volume of oil at high pressure.

Models designated “URT” have threaded ports and require a separate check valve to function as an unloading circuit.

“X” Series Pressure Reducing Valves

These pressure reducing valves maintain a reduced level of outlet pressure regardless of variations in inlet pressure above the pressure setting of the valve. The valves also allow reverse free flow at pressures below the setting of the valve.

Table of Contents

Series R(C)*-03/06/10/12 Sequence, Unloading, Back Pressure, and Counterbalance Valves	3
Series URT*-06/10 Unloading Relief Valves	14
Series URG*-06/10 Unloading Relief Valves	17
Series XSL/XTL-03 Pressure Reducing Valves	21
Series XGL-03 Pressure Reducing Valves	23
Series X(C)*-03/06/10 Pressure Reducing Valves	26
Application Data	35

Series R(C)*-03/06/10/12 Sequence, Unloading, Back Pressure, and Counterbalance Valves

Ratings

Rated Pressure (Maximum)*	210 bar (3000 psi)
Rated Capacity (Maximum)**	
R*-03	45 l/min (12 USgpm)
R*-06	114 l/min (30 USgpm)
R*-10 and R*-12	284 l/min (75 USgpm)

* 140 bar (2000 psi) permitted on the full piston area at the bottom cover ("P" connection), and at the top cover (spring chamber). See tank drain information on page 4.

**Rated capacities are based on using fluid with a specific gravity of 0.865 and a viscosity of 20 cSt (100 SUS).

Model Code

(F3)R(C)S - 06 - B P 1 - 30

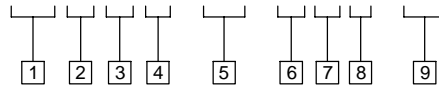

1 Special seals

F3 – For mineral oil and fire resistant fluids. Mounting face seals of RCG model are standard Buna-N unless specified as F3.
Blank – Omit for standard, R(C)S, and R(C)T models.

2 Valve type

R – Pressure control valve

3 Integral check valve

C – Reverse free flow check

4 Connections

G – Manifold or subplate mounting
S – SAE straight thread
T – NPTF thread*

*Not recommended

5 Valve size

03 – 3/8" pipe or 0.7500-16 UNF-2B straight thread (0.500 tubing)
06 – 3/4" pipe or 1.0625-12 UN-2B straight thread (0.750 tubing)
10 – 1 1/4" pipe or 1.6250-12 UN-2B straight thread (1.250 tubing)
12 – 1 1/2" pipe or 1.8750-12 UN-2B straight thread (1.500 tubing) (not available in R(C)G models)

6 Pressure range

X – 0,7 to 2,1 bar (10 to 30 psi)
Y – 2,1 to 4,1 bar (30 to 60 psi)
Z – 4,1 to 8,5 bar (60 to 125 psi)
A – 5,2 to 17,2 bar (80 to 250 psi)
B – 8,5 to 35 bar (125 to 500 psi)
D – 17,2 to 70 bar (250 to 1000 psi)
F – 35 to 140 bar (475 to 2000 psi)

7 Remote control connection

P – Auxiliary remote pressure control connection (not available with X, Y, or Z pressure ranges or in R(C)G-03 models)
Blank – Omit if not required

8 Valve application type

1 – Internal drain directly operated
2 – External drain directly operated
3 – External drain remotely operated
4 – Internal drain remotely operated

9 Design number

Subject to change. Installation dimensions same for designs 30 through 39.

Series R(C)*-03/06/10/12 Sequence, Unloading, Back Pressure, and Counterbalance Valves

General Data

Vickers "hydrocushion" type pressure control valves are used to control the sequencing, unloading, back pressure, and counterbalancing of oil flow in hydraulic systems. Control is initiated by a pressure rise which can be sensed either internally (directly) or remotely. Models are available with or without integral reverse free flow checks.

Pressure Adjustment

Pressure ranges – (see model code page 3) are maximum controllable, and each model selected should be well within the range given to afford fine increments of adjustment. Pressure setting must be at least 17 bar (250 psi) lower than the system relief valve setting.

Pressure can be adjusted by loosening a jam nut and turning an adjustment screw. Turning clockwise increases pressure, and turning counterclockwise decreases pressure.

Installation Data

Mounting

Because all R(C)T and R(C)S models have optional pressure inlets connected by a through passage, the valves may be mounted "in-line". The valves may also be teed to a line by using either one of the pressure inlets and plugging the other.

The remote pressure control connection on type 3 and 4 valves must be connected to an external pilot pressure source sufficient to operate the valve at the desired pressure setting and flow conditions.

Tank Drain

The discharge outlet of valve types 1 and 4 must be piped to tank at atmospheric pressure. The drain connection on types 2 and 3 must be piped directly to tank at atmospheric pressure. Any pressure at the drain port must be added to the pressure setting of the valve.

Auxiliary Remote Pressure Control "P"

All models (except R(C)G -03 and those with an "X", "Y", or "Z" pressure adjustment range in their model code) are available with an auxiliary remote control connection. Required pressure at the auxiliary connection is $1/16$ of the normally required control pressure for the "F" pressure range and $1/8$ of the normally required control pressure for the "A", "B", and "D" pressure ranges. (This applies to -22 design and up.)

Brake Valve

A brake valve is used in the exhaust line of a hydraulic motor to: 1) prevent overspeeding when an overrunning load is applied to the motor shaft; and 2) prevent excessive pressure buildup when decelerating or stopping a load.

When the "RC" valve is used as a brake valve, it has a solid spool (no drain hole through the center), and there is a remote operating pressure connection in the bottom cover directly under the spool. This connection is teed into the supply line to the motor. The internal control connection is also used under the small piston and senses pressure from the primary port of the "RC" valve, which is connected to the motor exhaust port.

When the load is being accelerated, pressure is maximum at the motor inlet and under the large area of the brake valve spool, holding it in the full open position and permitting free flow from the exhaust port of the motor.

When the motor gets up to speed, load pressure still holds the brake valve open unless the load tries to run away. If this happens, the pressure falls off at the motor inlet and in the remote control pressure passage. The spring force tends to close the valve, thus increasing the back pressure on the motor, tending to brake it.

When the directional valve is shifted to neutral, inertia may cause the motor to continue rotating against the brake valve. Until the motor stops turning, it will operate as a pump, drawing fluid from the motor outlet through the directional valve and circulating it back to the motor inlet. Motor leakage oil will be made up by drawing oil into the loop through the tank port of the valve. At this time, pressure at the motor outlet tending to bring it to a stop will be whatever is required under the small piston to overcome the brake valve setting.

Typical Application: Brake Valve

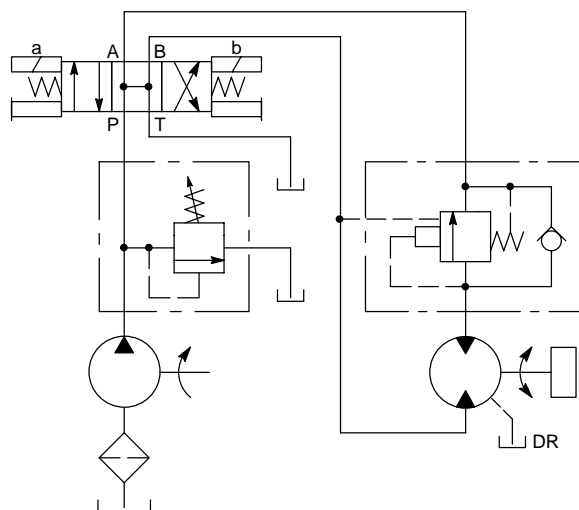

Series R(C)*-03/06/10/12 Sequence, Unloading, Back Pressure, and Counterbalance Valves

Pressure Drop

The following table lists approximate pressure drops (ΔP) when passing flow of fluid with a specific gravity of 0.865 and a viscosity of 20 cSt (100 SUS).

Valve	Reverse Free Flow Pressure Drop	
	Flow l/min (USgpm)	ΔP bar (psi)
RC*-03	45 (12)	5,5 (80)
RC*-06	114 (30)	3,4 (50)
RC*-10	189 (50)	2,8 (40)
RC*-12	189 (50)	2,4 (35)

For any other flow rate (Q_1), the approximate pressure drop (ΔP_1) can be calculated using the following formula:

$$\Delta P_1 = \Delta P (Q_1 / Q_2)^2.$$

For any other viscosity of fluid, the pressure drop will change according to the following table:

Viscosity cSt (SUS)	Approximate % of ΔP
14 (75)	93
27 (150)	111
38 (200)	119
46 (250)	126
56 (300)	132
64 (350)	137
74 (400)	141

For any other specific gravity (G_1), the approximate pressure drop (ΔP_1) can be calculated using the following formula:

$$\Delta P_1 = \Delta P (G_1 / G).$$

The specific gravity of fluid may be obtained from its producer. The value is higher for fire-resistant fluids than for oil.

Maximum Total Leakage vs. Pressure Drop

The following graph shows the relationship between maximum total leakage and pressure drop for fluid with a specific gravity of 0.865 and a viscosity of 20 cSt (100 SUS). Leakage is approximately proportional to viscosity in centistokes.

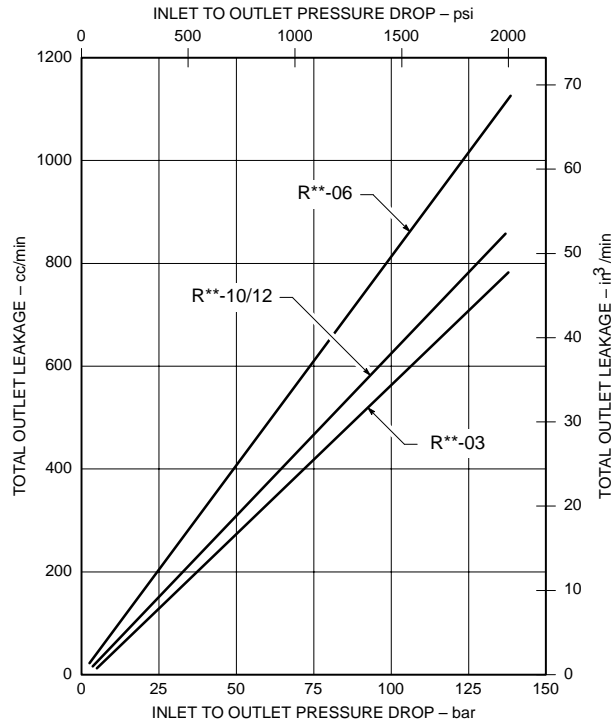

Series R(C)*-03/06/10/12 Sequence, Unloading, Back Pressure, and Counterbalance Valves

Installation Dimensions

Millimeters (inches)

Subplate or Manifold Mounted Models

RG-**-**-30 Without Check

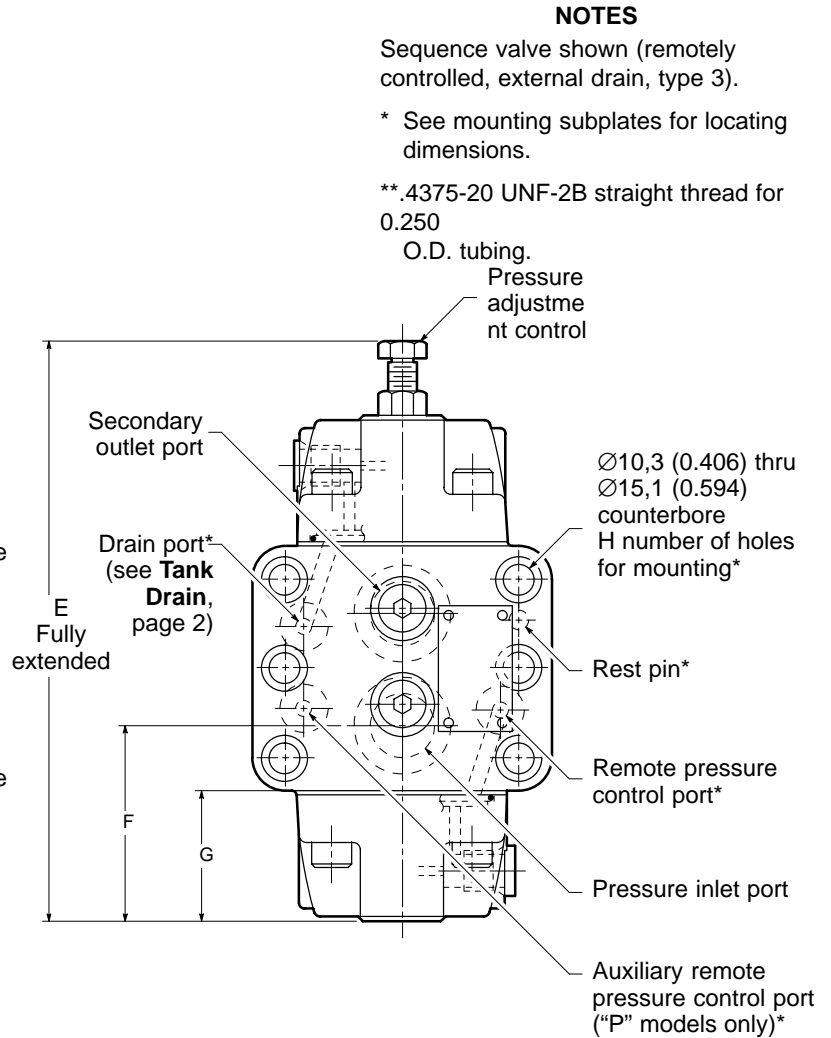
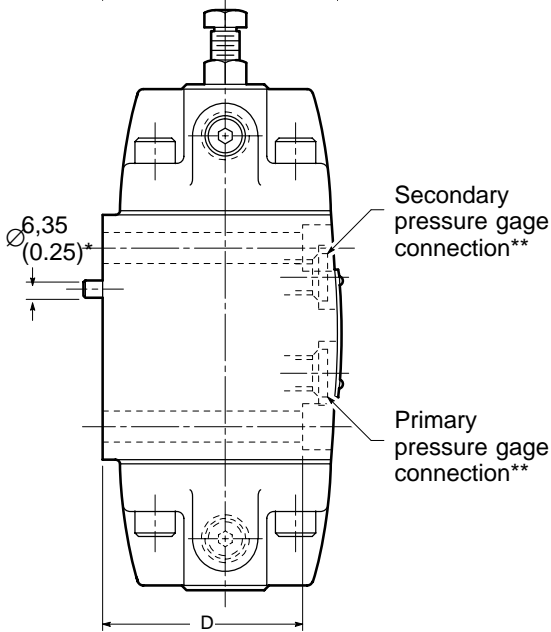
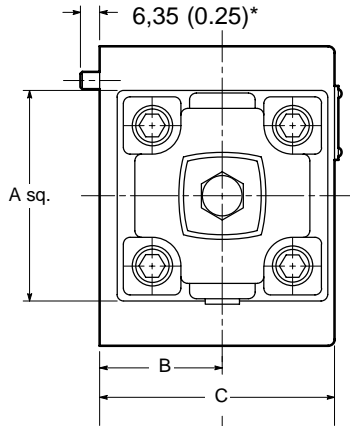

NOTES

Sequence valve shown (remotely controlled, external drain, type 3).

* See mounting subplates for locating dimensions.

** .4375-20 UNF-2B straight thread for 0.250 O.D. tubing.

Model	A	B	C	D	E	F	G	H	J	NFPA Interface
R(C)G-03-**-30	57,2 (2.25)	36,6 (1.44)	68,1 (2.68)	55,9 (2.20)	178,6 (7.03)	47,5 (1.87)	30,0 (1.18)	4	90,4 (3.56)	P03
R(C)G-06-**-30	71,4 (2.81)	41,1 (1.62)	79,2 (3.12)	73,7 (2.90)	201,4 (7.93)	67,6 (2.66)	45,2 (1.78)	4	98,6 (3.88)	P06
R(C)G-10-**-30	95,2 (3.75)	50,8 (2.00)	100,1 (3.94)	90,2 (3.55)	282,2 (11.11)	71,6 (2.82)	44,4 (1.75)	6	130,0 (5.12)	P10

Series R(C)*-03/06/10/12 Sequence, Unloading, Back Pressure, and Counterbalance Valves

RCG- ** - ** -30 With Check

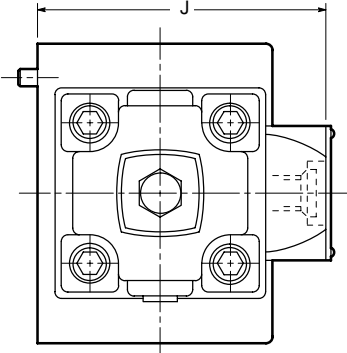

NOTE
Sequence valve shown (remotely controlled, external drain, type 3).

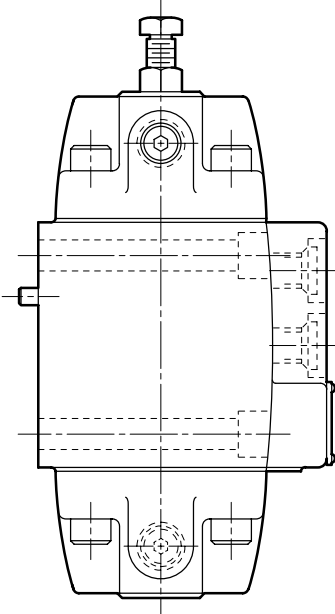

Series R(C)*-03/06/10/12 Sequence, Unloading, Back Pressure, and Counterbalance Valves

Threaded Port Models

RS/T-**-**-30 Without Check

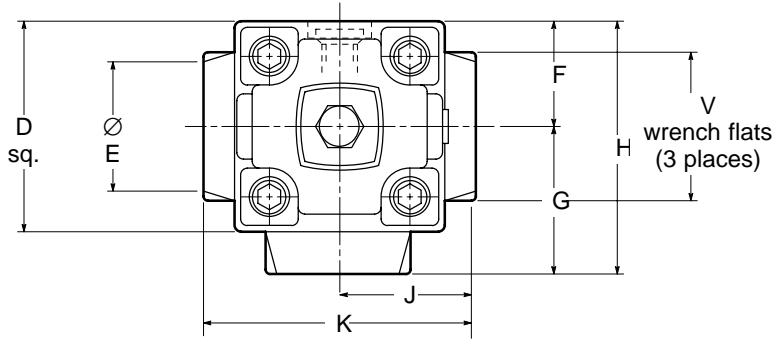

NOTES

Sequence valve shown (directly operated, external drain, type 2).

All external connections are straight thread (except inlet and outlet ports of R(C)T models).

*.4375-20 UNF-2B straight thread for 0.250 O.D. tubing.

** .5627-18 UNF-2B thread

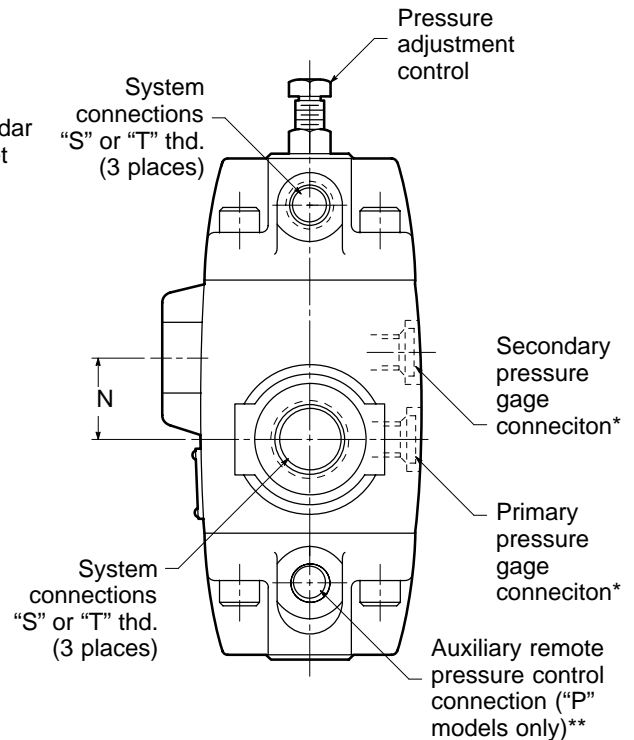
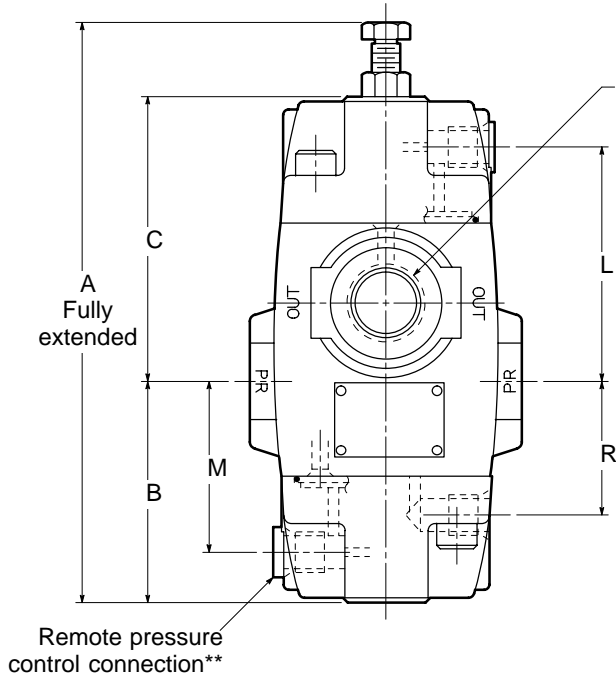

Model	A	B	C	D	E	F	G	H	J	K
R(C)S/T-03-**-30	178,6 (7.03)	53,3 (2.12)	96,8 (3.81)	59,4 (2.34)	35,1 (1.38)	29,7 (1.17)	39,6 (1.56)	70,9 (2.79)	35,1 (1.38)	69,8 (2.75)
R(C)S/T-06-**-30	201,4 (7.93)	75,4 (2.97)	97,8 (3.85)	74,7 (2.94)	47,8 (1.88)	37,3 (1.47)	50,8 (2.00)	88,1 (3.47)	47,8 (1.88)	95,2 (3.75)
R(C)S/T-10-**-30	282,2 (11.11)	84,1 (3.31)	154,2 (6.07)	98,6 (3.88)	82,6 (3.25)	49,3 (1.94)	68,3 (2.69)	117,6 (4.63)	53,8 (2.12)	108,0 (4.25)
R(C)S/T-12-**-30	282,2 (11.11)	84,1 (3.31)	154,2 (6.07)	98,6 (3.88)	82,6 (3.25)	49,3 (1.94)	68,3 (2.69)	117,6 (4.63)	53,8 (2.12)	108,0 (4.25)

Series R(C)*-03/06/10/12 Sequence, Unloading, Back Pressure, and Counterbalance Valves

RCS/T-**-**-30 With Check

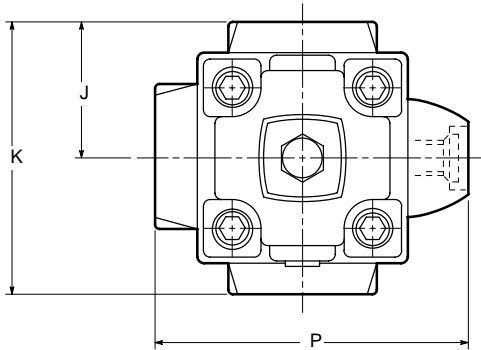

NOTE
Sequence valve shown (remotely controlled, external drain, type 3).

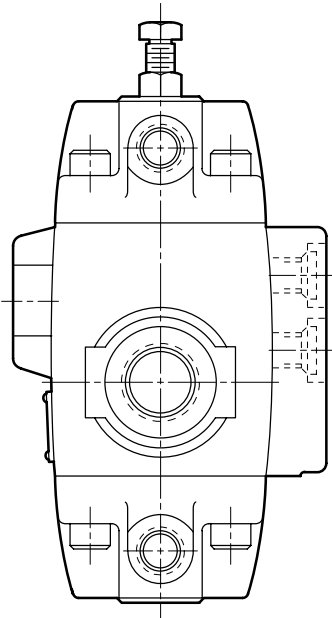

Model	L	M	N	P	R●	“S” Str. Thd. RS and RCS Models	“T” Str. Thd.■ RT and RCT Models	V
R(C)S/T-03-**-30	58,7 (2.31)	42,9 (1.69)	23,1 (0.91)	93,7 (3.69)	38,9 (1.53)	.7500-16 UNF-2B	3/8	35,1 (1.38)
R(C)S/T-06-**-30	79,5 (3.13)	57,2 (2.25)	27,2 (1.07)	108,0 (4.25)	46,7 (1.84)	1.0625-12 UN-2B	3/4	50,8 (2.00)
R(C)S/T-10-**-30	80,3 (3.16)	70,6 (2.78)	28,7 (1.13)	147,6 (5.81)	57,2 (2.25)	1.6250-12 UN-2B	1 1/4	86,4 (3.40)
R(C)S/T-12-**-30	80,3 (3.16)	70,6 (2.78)	28,7 (1.13)	147,6 (5.81)	57,2 (2.25)	1.8750-12 UN-2B	1 1/2	86,4 (3.40)

● For “P” models only. See model code.
■ Not recommended.

Series R(C)*-03/06/10/12 Sequence, Unloading, Back Pressure, and Counterbalance Valves

Mounting Subplates

When a subplate is not used, a machined pad (as indicated by shaded area) must be provided for mounting. The pad must be flat within 0,013 mm (0.0005 in) and smooth within 1,6 μm (63 microinch). Mounting bolts provided by the customer should be SAE grade 7 or better.

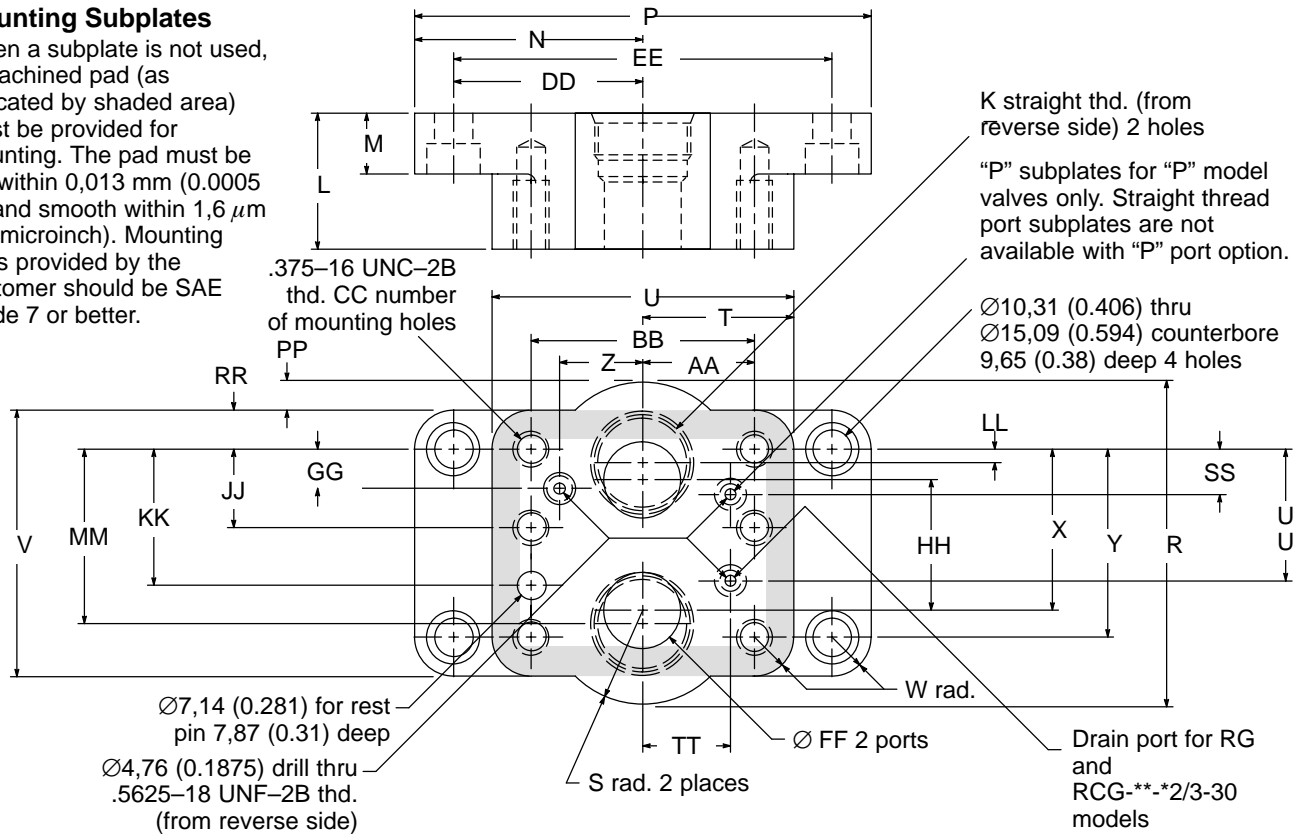

Model	K	Tube O.D.	L	M	N	P	R	S	T	U	V
RXGM-03S-(P)-20	.7500-16 UNF-2B	1/2"	25,4 (1.00)	19,0 (0.75)	63,5 (2.50)	127,0 (5.00)	76,2 (3.00)	23,9 (0.94)	43,7 (1.72)	87,4 (3.44)	63,5 (2.50)
RXGM-06SX-(P)-20	1.3125-1 2 UN-2B	1"	31,8 (1.25)	19,0 (0.75)	73,2 (2.88)	146,0 (5.75)	117,3 (4.62)	39,6 (1.56)	50,8 (2.00)	101,6 (4.00)	82,6 (3.25)
RXGM-10S-(P)-30	1.6250-1 2 UN-2B	1 1/4"	47,8 (1.88)	22,4 (0.88)	79,2 (3.12)	158,8 (6.25)	146,0 (5.75)	47,8 (1.88)	58,7 (2.31)	117,3 (4.62)	104,6 (4.12)

Model	W	X	±0,13 Y (±0.005)	Z	AA	BB	CC	DD	±0,013 EE (±0.005)	FF	GG
RXGM-03S-(P)-20	10,4 (0.41)	35,8 (1.41)	42,87 (1.688)	25,4 (1.00)	33,3 (1.31)	66,5 (2.62)	4	53,1 (2.09)	106,37 (4.188)	14,2 (0.56)	21,3 (0.84)
RXGM-06SX-(P)-20	10,2 (0.44)	49,3 (1.94)	60,32 (2.375)	33,3 (1.31)	39,6 (1.56)	79,2 (3.12)	4	62,0 (2.44)	123,82 (4.875)	23,1 (0.91)	20,6 (0.81)
RXGM-10S-(P)-30	10,4 (0.41)	67,6 (2.66)	84,12 (3.312)	44,4 (1.75)	48,5 (1.91)	96,8 (3.81)	6	69,1 (2.72)	138,12 (5.438)	28,4 (1.12)	24,6 (0.97)

Model	HH	JJ■	KK	LL	MM	PP	RR	SS	TT	UU	NFPA Interface
RXGM-03S-(P)-20	28,4 (1.12)	—	31,8 (1.25)	4,8 (0.19)	38,1 (1.50)	6,4 (0.25)	10,4 (0.41)	—	25,4 (1.00)	21,3 (0.84)	P03
RXGM-06SX-(P)-20	38,1 (1.50)	—	44,4 (1.75)	6,4 (0.25)	53,8 (2.12)	17,5 (0.69)	11,2 (0.44)	16,8 (0.66)	33,3 (1.31)	39,6 (1.56)	P06
RXGM-10S-(P)-30	50,8 (2.00)	42,2 (1.66)	62,7 (2.47)	7,9 (0.31)	76,2 (3.00)	20,6 (0.81)	10,4 (0.41)	24,6 (0.97)	44,4 (1.75)	59,4 (2.34)	P10

■ RXGM-03S/06SX require 4 valve mounting screws. RXGM-10S requires 6 valve mounting screws.

Series R(C)*-03/06/10/12 Sequence, Unloading, Back Pressure, and Counterbalance Valves

Graphical Symbols

Type P Back Pressure and Counterbalance Valves

Auxiliary remote control operated with "P" connection – Internal drain (model "P1" shown)

R(C)G Valves

Back Pressure (RG)

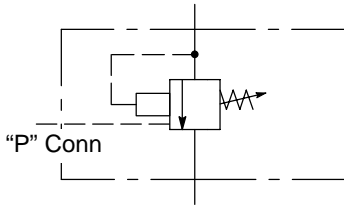

Counterbalance (RCG)

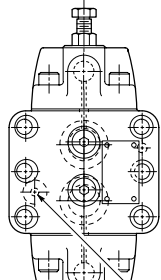
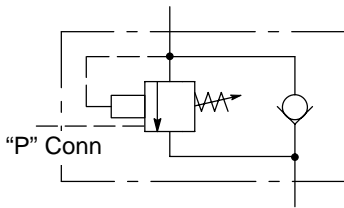

Auxiliary remote pressure control port for "P" models only

R(C)S/T Valves

Back Pressure (RS/T)

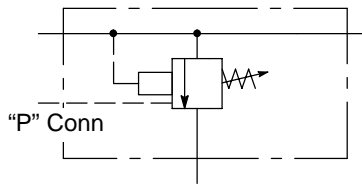

Counterbalance (RCS/T)

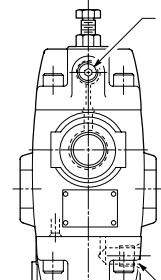
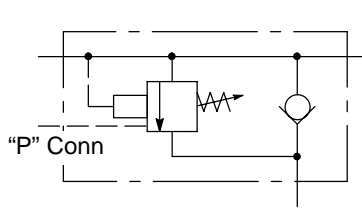

Plug in place

Auxiliary remote pressure control port for "P" models only

Type 1 Back Pressure and Counterbalance Valves

Internally operated – Internal drain

R(C)G Valves

Back Pressure (RG)

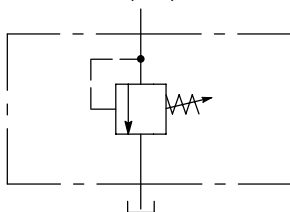

Counterbalance (RCG)

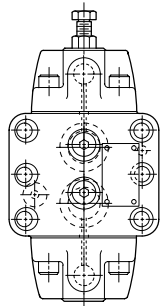
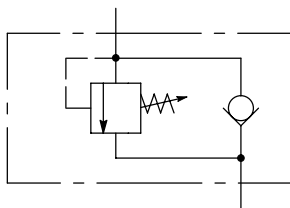

R(C)S/T Valves

Back Pressure (RS/T)

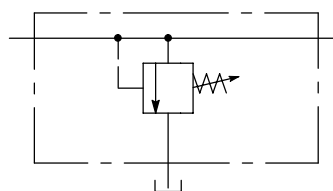

Counterbalance (RCS/T)

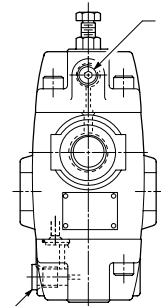
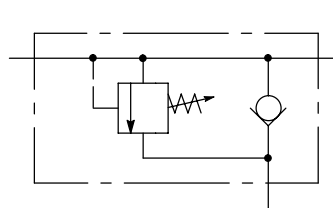

Plug in place

Plug in place

Series R(C)*-03/06/10/12 Sequence, Unloading, Back Pressure, and Counterbalance Valves

Type 2 Sequence Valves

Internally operated – External drain

R(C)G Valves

(RG)

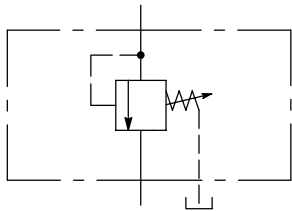

(RCG)

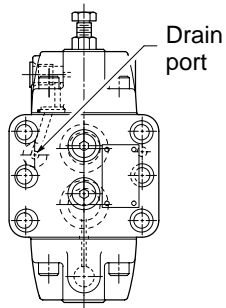
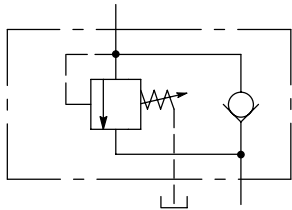

R(C)S/T Valves

(RS/T)

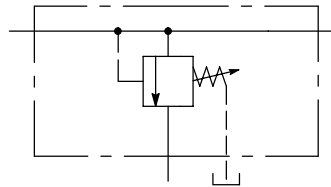

(RCS/T)

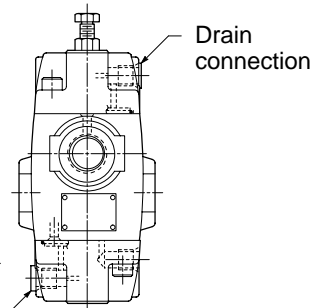
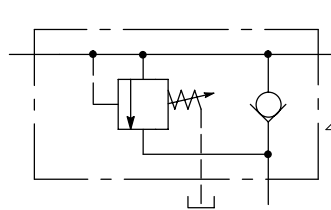

Type 3 Sequence Valves

Remote control operated – External drain

R(C)G Valves

(RG)

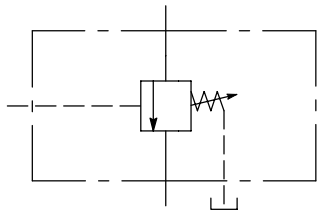

(RCG)

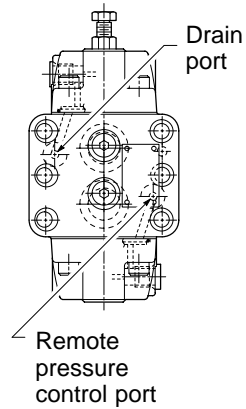
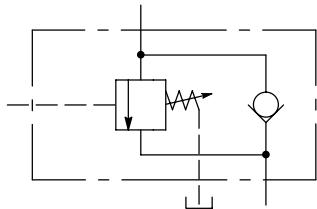

R(C)S/T Valves

(RS/T)

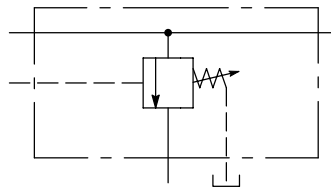

(RCS/T)

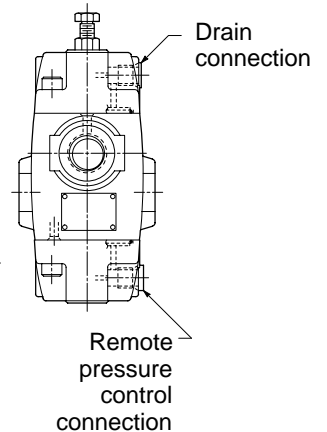
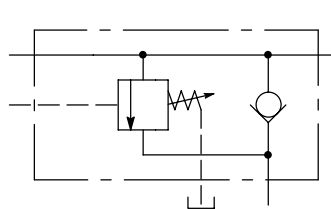

Series R(C)*-03/06/10/12 Sequence, Unloading, Back Pressure, and Counterbalance Valves

Type 4 Unloading and Counterbalance Valves

Remote control operated – Internal drain

R(C)G Valves

Unloading (RG)

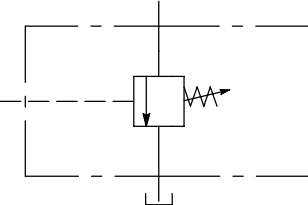

Counterbalance (RCG)

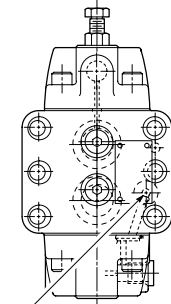
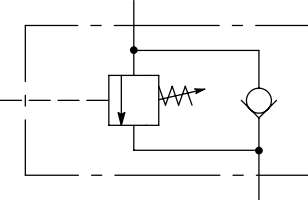

Remote pressure control port

R(C)S/T Valves

Unloading (RS/T)

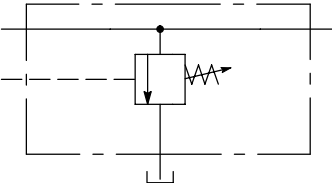

Counterbalance (RCS/T)

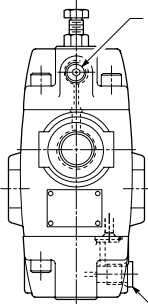
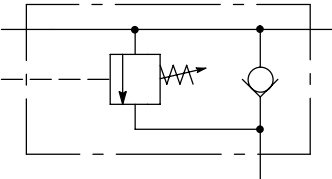

Plug in place

Remote pressure control connection

Series URT*-06/10 Unloading Relief Valves

Ratings

Rated Pressure (Maximum)	210 bar (3000 psi)
Rated Capacity (Maximum)	
URT*-06	76 l/min (20 USgpm)
URT*-10	189 l/min (50 USgpm)

Model Code

(F3)U R T 1 - 06 - C(V) - 10

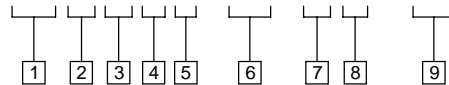

1 Special seals

F3 – For mineral oil and fire resistant fluids
Blank – Omit for standard models

2 Valve function

U – Unloading valve

3 Valve type

R – Pressure control valve

4 Connections

T – NPTF thread*
*Not recommended

5 Drain

1 – Externally drained
2 – Internally drained

6 Valve size

06 – 3/4" pipe
10 – 1 1/4" pipe

7 Cutout pressure range

B – 24 to 70 bar (350 to 1000 psi)
C – 35 to 140 bar (500 to 2000 psi)
F – 103 to 210 bar (1500 to 3000 psi)

8 High vent spring

V – Optional high vent spring installed
Blank – Omit if not required

9 Design number

Subject to change. Installation dimensions same for designs 10 through 19.

General Data

These valves are used in oil hydraulic circuits where a pressure regulator is required to automatically unload the pump by diverting the pump delivery to the reservoir, at low pressure, when the accumulator pressure reaches the desired maximum (or "cut out") pressure. When the accumulator pressure drops to the "cut in" pressure (approximately 85% of the desired maximum), the valve directs pump delivery to the accumulator and

hydraulic system. The valve may also be used with a double pump to deliver a large volume of oil to the system at low pressure and a small volume at high pressure, serving the same function as an unloading valve. A separate right angle check valve, C2-815 (3/4") or C2-825 (1 1/4") must be provided to maintain accumulator hydraulic charge or unloading of high volume pump and prevent back flow when pump is unloaded.

Pressure Adjustment

Pressure can be adjusted by loosening a jam nut and turning an adjustment screw. Turning clockwise increases pressure, and turning counterclockwise decreases pressure.

Series URT*-06/10 Unloading Relief Valves

Installation Data

Tank Drain

Back pressure at the tank discharge port of the URT1 series (externally drained) valves will not effect the operation at up to 85% of the inlet pressure. Back pressure at the tank discharge port of the URT2 series (internally drained) valves must not exceed 5% of the inlet pressure.

CAUTION

For series URT1 only, the drain must be connected to tank through a surge free line so there will be no back pressure at this drain. Failure to connect drain can result in infinite system pressures and machine damage. Series URT2 has internal drain and this port is not used.

Connections

Pressure inlet and outlet connections are connected by a through passage which permits use of either connection as an inlet.

Approximate Minimum Venting Pressures bar (psi) at Various Percentages of Maximum Rated Capacity

Model	25%	50%	75%	100%
URT*-06-*-10	0,7 (10)	0,8 (11)	1,0 (15)	1,6 (23)
URT*-06-*V-10	3,9 (56)	3,9 (57)	4,1 (59)	4,3 (63)
URT*-10-*-10	0,4 (6)	0,7 (10)	1,6 (23)	2,7 (39)
URT*-10-*V-10	3,6 (52)	3,7 (54)	3,9 (57)	4,1 (59)

Typical Applications

Double Pump Circuit

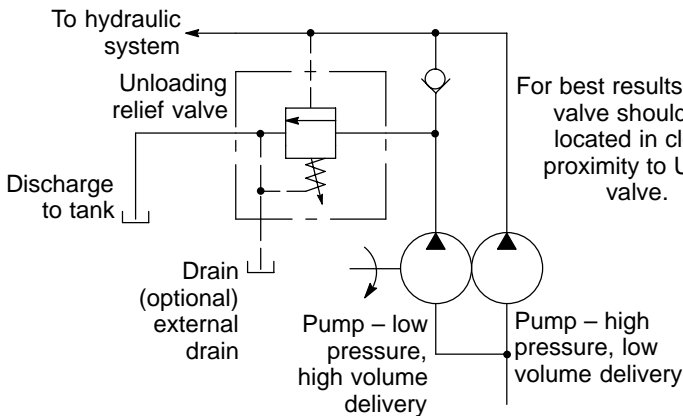

Accumulator Circuit

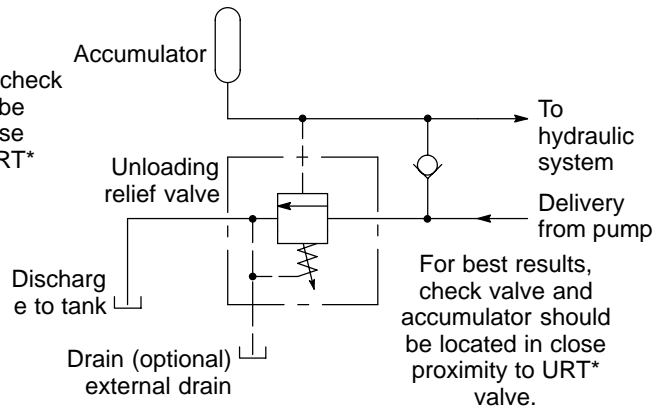

Series URT*-06/10 Unloading Relief Valves

Installation Dimensions

Millimeters (inches)

**URT1 and URT2 with Threaded Connections
for 3/4" and 1 1/4" Piping**

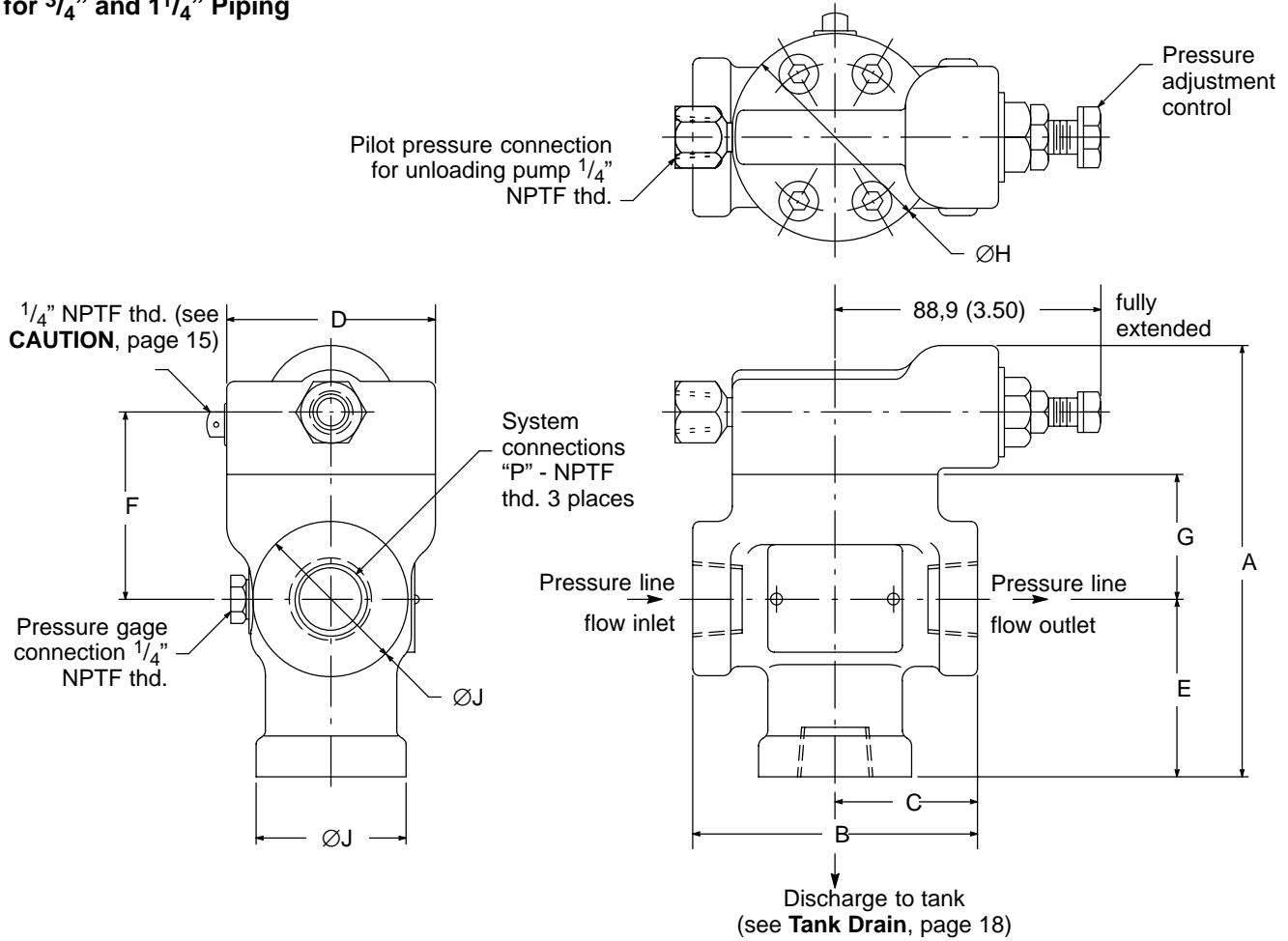

Model	"P" Piping Thd. Size NPTF	Nominal Capacity l/min (USgpm)	A	B	C	D	E	F	G	H	J
URT*-06-*-10	3/4"	76 (20)	158,8 (6.25)	108,0 (4.25)	53,8 (2.12)	77,7 (3.06)	65,0 (2.56)	68,3 (2.69)	46,0 (1.81)	76,2 (3.00)	57,2 (2.25)
URT*-10-*-10	1 1/4"	189 (50)	189,0 (7.44)	127,0 (5.00)	63,5 (2.50)	95,2 (3.75)	77,7 (3.06)	87,4 (3.44)	60,5 (2.38)	95,2 (3.75)	76,2 (3.00)

Series URG*-06/10 Unloading Relief Valves

Ratings

Rated Pressure (Maximum)	210 bar (3000 psi)
Rated Capacity (Maximum)	
URT*-06	95 l/min (25 USgpm)
URT*-10	246 l/min (65 USgpm)

Model Code

(F3)U R G 1 - 06 - C(V) - 10

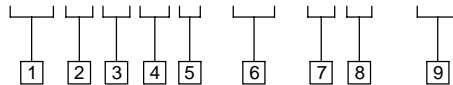

1 Special seals

F3 – For mineral oil and fire resistant fluids
Blank – Omit for standard models

2 Valve function

U – Unloading valve

3 Valve type

R – Pressure control valve

4 Connections

G – Manifold or subplate mounted

5 Drain

1 – Externally drained
2 – Internally drained

6 Valve size

06 – 3/4" pipe
10 – 1 1/4" pipe

7 Cutout pressure range

B – 24 to 70 bar (350 to 1000 psi)
C – 35 to 140 bar (500 to 2000 psi)
F – 103 to 210 bar (1500 to 3000 psi)

8 High vent spring

V – Optional high vent spring installed
Blank – Omit if not required

9 Design number

Subject to change. Installation dimensions same for designs 10 through 19.

General Data

These valves are used in oil hydraulic circuits where a pressure regulator is required to automatically unload the pump by diverting the pump delivery to the reservoir, at low pressure, when the accumulator reaches the desired maximum (or "cut out") pressure. When the accumulator pressure drops to the "cut in" pressure (approximately 85% of the desired maximum), the valve directs pump delivery to the accumulator and hydraulic system. An integral check valve prevents return flow from the accumulator through the unloading valve.

The valve may also be used with a double pump to deliver a large volume of oil to the system at low pressure and a small volume at high pressure, serving the same function as a separate unloading valve and check valve.

Pressure Adjustment

Pressure can be adjusted by loosening a jam nut and turning an adjustment screw. Turning clockwise increases pressure, and turning counterclockwise decreases pressure.

Series URG*-06/10 Unloading Relief Valves

Installation Data

Tank Drain

Back pressure at the tank discharge port of the URG1 series (externally drained) valves will not effect the operation at up to 85% of the inlet pressure. Back pressure at the discharge port of the URG2 series (internally drained) valves must not exceed 5% of the inlet pressure.

CAUTION

For series URG1 only, the drain must be connected to the tank through a surge free line so there will be no back pressure at this drain. Failure to connect drain can result in infinite system pressures and machine damage. Series URG2 has internal drain and this port is not used.

Model	Nominal Capacity l/min (USgpm)	Cut Out Pressure Range bar (psi)	Approximate Pressure Drop bar (psi)	
			Unloading	Via Check To Accumulator
URG*-06-B-10	95 (25)	24 to 70 (350 to 1000)	5,9 (85)	2,4 (35)
URG*-06-C-10		35 to 140 (500 to 2000)		
URG*-06-F-10		103 to 207 (1500 to 3000)		
URG*-10-B-10	246 (65)	24 to 70 (350 to 1000)	2,4 (35)	1,1 (16)
URG*-10-C-10		35 to 140 (500 to 2000)		
URG*-10-F-10		103 to 207 (1500 to 3000)		

Typical Applications

Double Pump Circuit

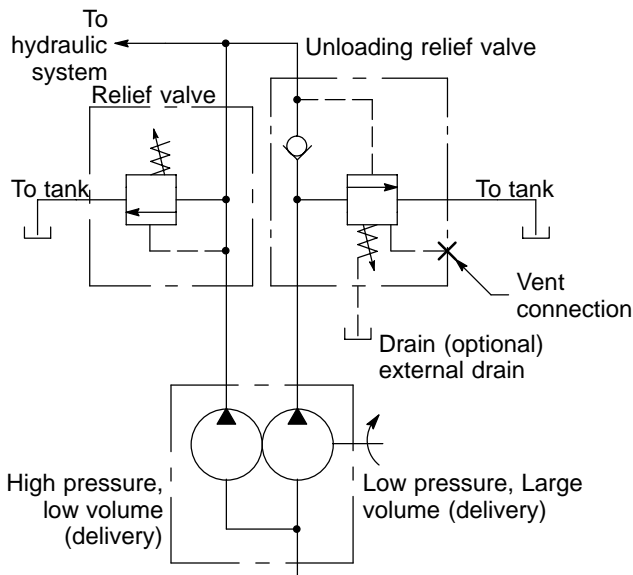

Accumulator Circuit

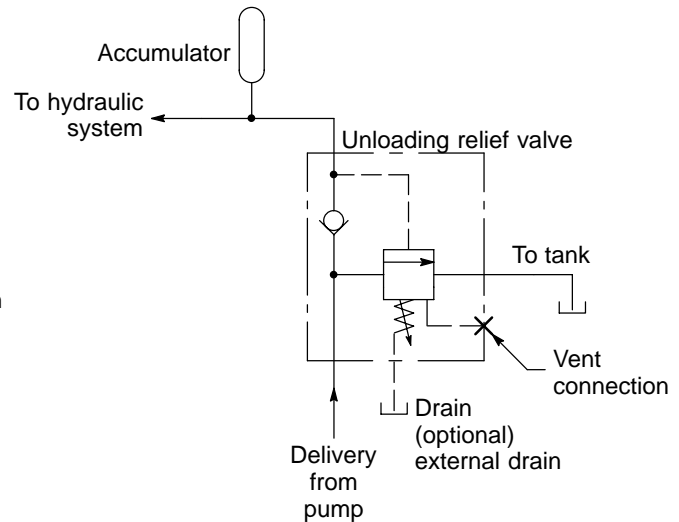

Series URG*-06/10 Unloading Relief Valves

Installation Dimensions

Millimeters (inches)

URG*-06/10 Valve

NOTES

- * See mounting subplates for locating dimensions.
- ** Keep plugged except when circuit indicates connection for venting valve.

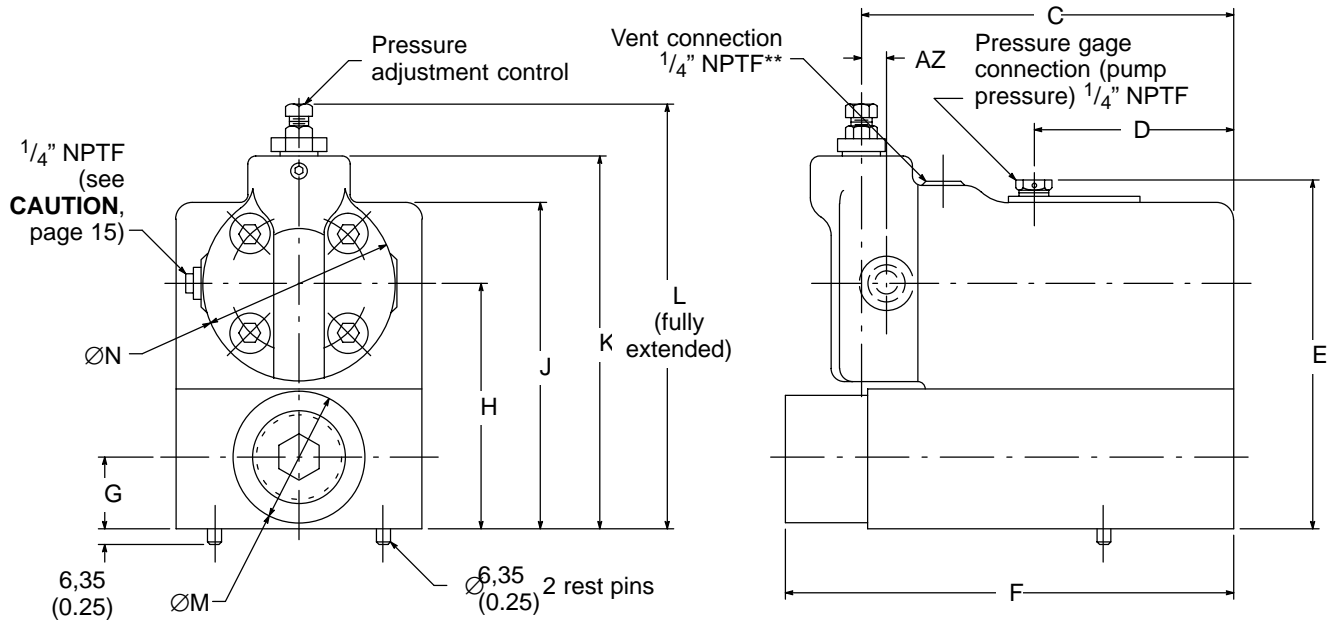
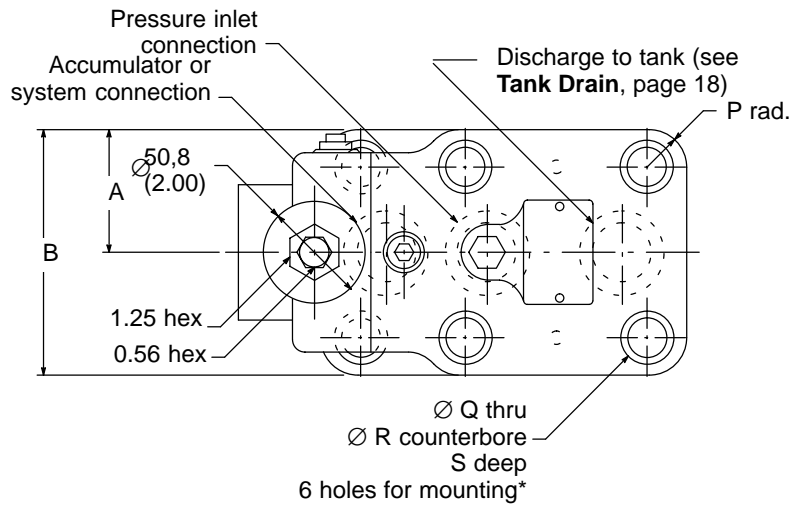

Model	A	B	C	D	E	F	G	H	J
URG*-06*-10	50,8 (2.00)	101,6 (4.00)	139,7 (5.50)	76,2 (3.00)	134,9 (5.31)	160,3 (6.31)	25,4 (1.00)	91,9 (3.62)	124,0 (4.88)
URG*-10*-10	60,5 (2.38)	120,6 (4.75)	179,3 (7.06)	95,2 (3.75)	168,1 (6.62)	217,4 (8.56)	33,3 (1.31)	117,3 (4.62)	157,2 (6.19)

Model	K	L	M	N	P	Q	R	S	AZ
URG*-06*-10	153,9 (6.06)	180,8 (7.12)	44,4 (1.75)	76,2 (3.00)	15,7 (0.62)	16,8 (0.66)	25,4 (1.00)	15,7 (0.62)	3,0 (0.12)
URG*-10*-10	179,3 (7.06)	206,2 (8.12)	63,5 (2.50)	95,2 (3.75)	19,0 (0.75)	17,8 (0.78)	29,5 (1.16)	19,0 (0.75)	1,5 (0.06)

Series URG*-06/10 Unloading Relief Valves

Mounting Subplates

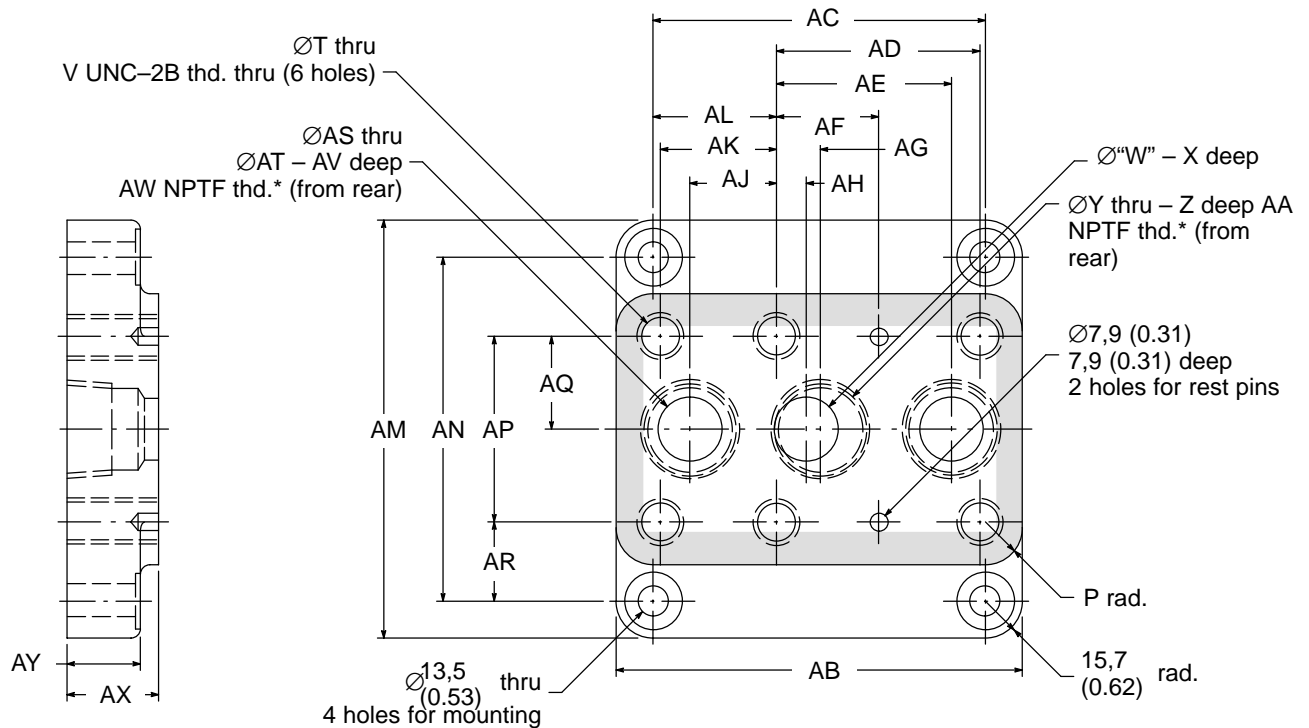

Model	P	T	V	W	X	Y	Z	AA	AB	AC
URG1M-06-10	15,7 (0.62)	14,0 (0.55)	.625-11	23,1 (0.91)	31,8 (1.25)	—	—	3/4"	144,5 (5.69)	112,71 (4.438)
URG1M-10-10	19,0 (0.75)	16,8 (0.66)	.750-10	28,4 (1.12)	11,2 (0.44)	38,1 (1.50)	30,5 (1.12)	1 1/4"	177,8 (7.00)	146,05 (5.750)
Model	AD	AE	AF	AG	AH	AJ	AK	AL	AM	AN
URG1M-06-10	66,5 (2.62)	55,6 (2.19)	33,3 (1.31)	11,2 (0.44)	10,2 (0.44)	33,3 (1.31)	46,0 (1.81)	46,0 (1.81)	162,1 (6.38)	130,18 (5.125)
URG1M-10-10	88,9 (3.50)	76,2 (3.00)	44,4 (1.75)	19,0 (0.75)	12,7 (0.50)	38,1 (1.50)	50,8 (2.00)	53,8 (2.12)	184,1 (7.25)	152,40 (6.000)
Model	AP	AQ	AR	AS	AT	AV	AW	AX	AY	
URG1M-06-10	69,8 (2.75)	35,1 (1.38)	30,2 (1.19)	23,1 (0.91)	—	—	3/4"	31,8 (1.25)	25,4 (1.00)	
URG1M-10-10	82,6 (3.25)	41,1 (1.62)	35,1 (1.38)	28,4 (1.12)	38,1 (1.50)	30,2 (1.19)	1 1/4"	38,1 (1.50)	31,8 (1.25)	

Series XSL/XTL-03 Pressure Reducing Valves

Ratings

Rated Capacity (Maximum)	30 l/min (8 USgpm)
Adjustable Pressure Range	3,4 to 70 bar (50 to 1000 psi)*
Inlet Pressure (Maximum)	140 bar (2000 psi)

* X*L-03-B-10-S21 model has adjustable pressure range of 1,7 to 21 bar (25 to 300 psi) with maximum inlet pressure of 70 bar (1000 psi).

Model Code

(F3)X T L - 03 - B - 10 - S21

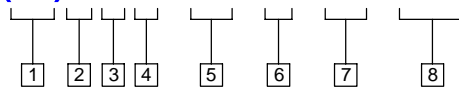

1 Special seals

F3 – For mineral oil and fire resistant fluids
Blank – Omit for standard models

2 Valve type

X – Pressure reducing valve

3 Connections

S – SAE straight thread
T – NPTF thread*

* Not recommended

4 Pressure level

L – Low pressure type

5 Valve size

03 – 3/8" pipe

6 Pressure range

B – 3,4 to 70 bar (50 to 1000 psi)

7 Design number

Subject to change. Installation dimensions same for designs 10 through 19.

8 Special feature suffix

S21 – Adjustable pressure range of 1,7 to 21 bar (25 to 300 psi) with maximum inlet pressure of 70 bar (1000 psi)
Blank – Omit if not required

General Data

The operation of these Vickers reducing valves is such that reduced outlet pressure remains constant regardless of variation of inlet pressure above the selected pressure setting. Reverse free flow is allowable, providing the pressure at the reduced pressure port does not exceed the reduced pressure setting of the valve.

Pressure Adjustment

A differential of at least 1,7 bar (25 psi) between inlet and outlet pressure must be maintained for proper functioning.

Adjustment of reduced outlet pressure is accomplished by loosening jam nut and turning pressure adjustment control. Clockwise rotation increases pressure. Counterclockwise rotation decreases pressure. Control adjustment has stops for minimum and maximum pressures.

Drain Connection

The drain connection must be piped directly to tank. Any pressure at this port must be added to the valve pressure setting.

Series XSL/XTL-03 Pressure Reducing Valves

Installation Dimensions

Millimeters (inches)

XS/TL-03-B-10 Valve

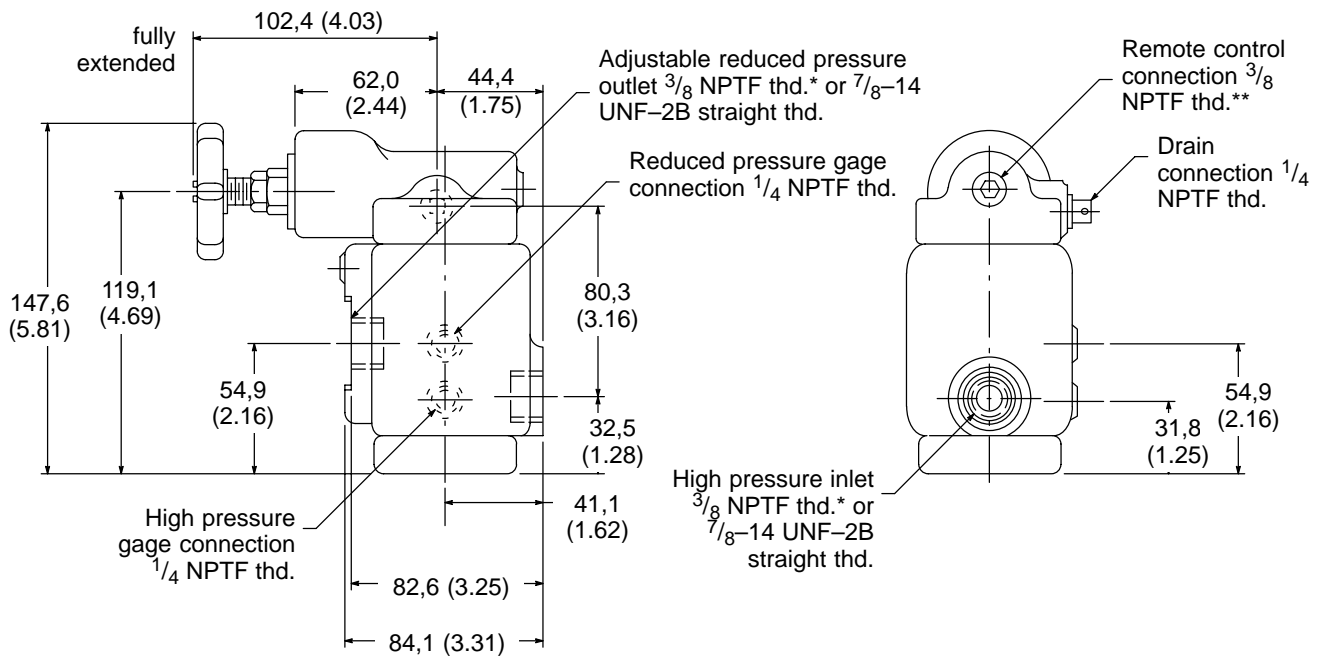
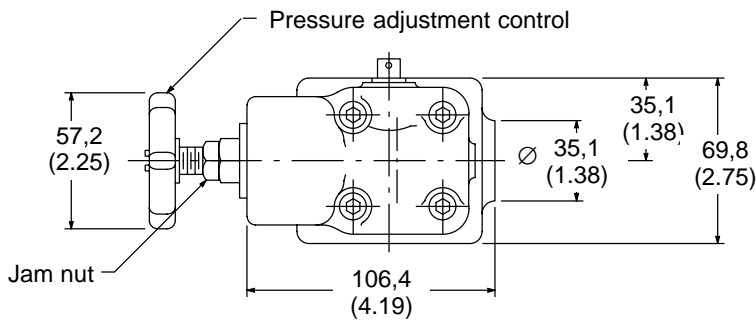
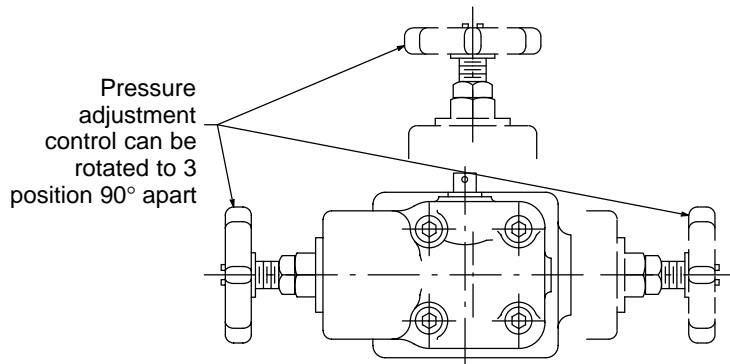

NOTES

Model XSL-03-B-10 is supplied with $\frac{7}{8}$ -14 straight thread system connections and a $\frac{9}{16}$ -18 straight thread drain connection.

X*L-03-B-10-S21 model has adjustable pressure range of 1,7 to 21 bar (25 to 300 psi) with maximum inlet pressure of 70 bar (1000 psi).

* Not recommended.

** Reduced pressure may be adjusted remotely by connecting this port to pressure inlet port of CGR-02-* -20 valve or C-175-* -10 valve. Pressure setting of main valve must be higher than that of remote control.

Series XGL-03 Pressure Reducing Valves

Ratings

Rated Capacity (Maximum)	30 l/min (8 USgpm)
Adjustable Pressure Range	1,7 to 70 bar (25 to 1000 psi)
Inlet Pressure (Maximum)	140 bar (2000 psi)

Model Code

(F3)X G L - 03 - B - 10

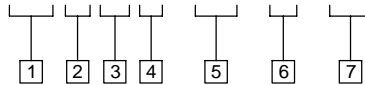

1 Special seals

F3 – For mineral oil and fire resistant fluids
Blank – Omit for standard models

2 Valve type

X – Pressure reducing valve

3 Connections

G – Manifold or subplate mounting

4 Pressure level

L – Low pressure type

5 Valve size

03 – $\frac{3}{8}$ " nominal size

6 Pressure range

B – 1,7 to 70 bar (25 to 1000 psi)

7 Design number

Subject to change. Installation dimensions same for designs 10 through 19.

General Data

The operation of these reducing valves is such that reduced outlet pressure remains constant regardless of variation of inlet pressure above the selected pressure setting. Reverse free flow is allowable, providing the pressure at the reduced pressure port does not exceed the reduced pressure setting of the valve.

Pressure Adjustment

A differential of at least 1,7 bar (25 psi) between inlet and outlet pressure must be maintained for proper functioning.

Adjustment of reduced outlet pressure is accomplished by loosening jam nut and turning pressure adjustment control. Clockwise rotation increases pressure. Counterclockwise rotation decreases pressure. Control adjustment has stops for minimum and maximum pressures.

Drain Connection

The drain connection must be piped directly to tank. Any pressure at this port must be added to the valve pressure setting.

Series XGL-03 Pressure Reducing Valves

Installation Dimensions

Millimeters (inches)

XGL-03-B-10 Valve

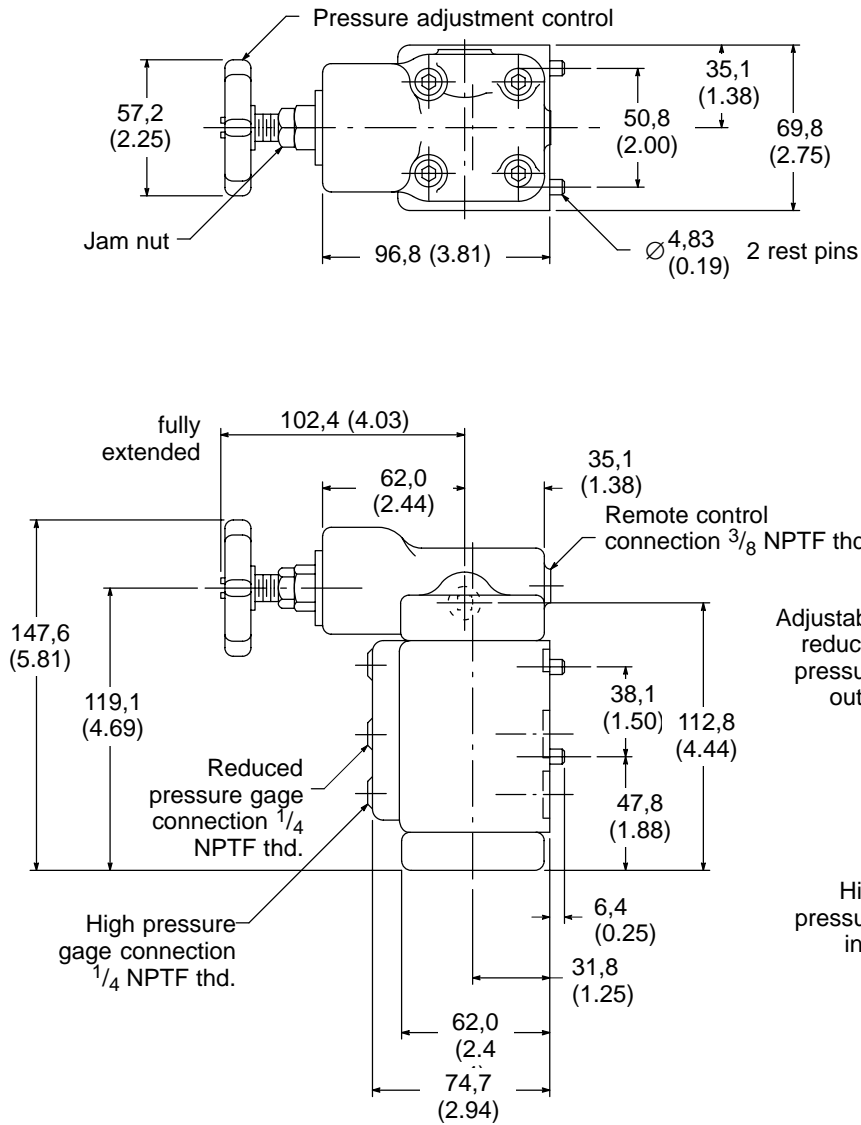

NOTE

* Reduced pressure may be adjusted remotely by connecting this port to pressure inlet port of CGR-02-*-20 valve or C-175-*-10 valve. Pressure setting of main valve must be higher than that of remote control.

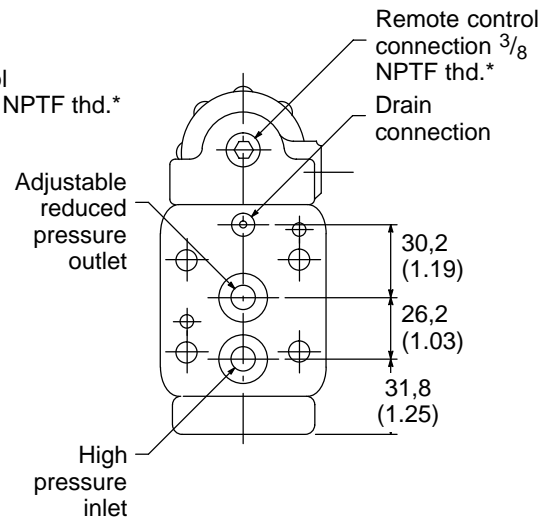

Series XGL-03 Pressure Reducing Valves

Mounting Subplate

Model XGLM-10S-03-10

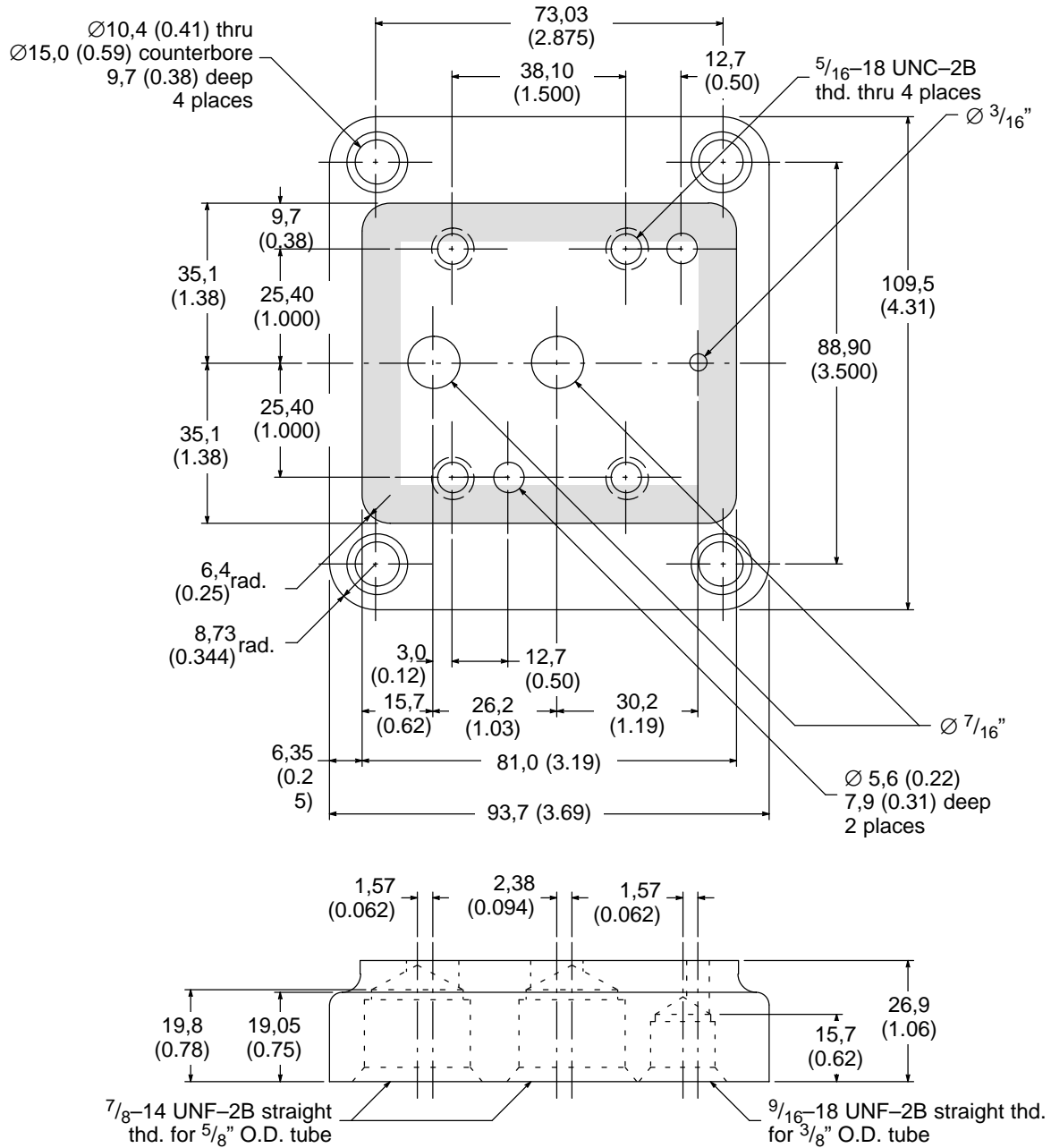

Series X(C)*-03/06/10 Pressure Reducing Valves

Ratings

Rated Capacity (Maximum)	530 l/min (140 USgpm)
Inlet Pressure (Maximum)	210 bar (3000 psi)

Model Code

(F3)X(C) * -(H) 06 - 2 B - 30

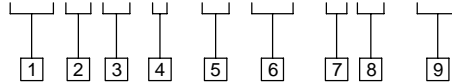

1 Special seals

F3 – For mineral oil and fire resistant fluids
 Blank – Omit for standard models

2 Valve type

X – Pressure reducing valve

3 Integral check valve

C – Reverse free flow check

4 Connections

G – Manifold or subplate mounting
 S – SAE straight thread
 T – NPTF thread*

* Not recommended

5 High-flow designation

H – High-flow valve

Size	Flow l/min (USgpm)
03	114 (30)
06	265 (70)
10	530 (140)

 Blank – Omit for 'B' and 'F' models

6 Valve size

03 – 3/8" pipe or 0.7500-16 UNF-2B straight thread (0.500 tubing)
 06 – 3/4" pipe or 1.0625-12 UN-2B straight thread (0.750 tubing)
 10 – 1 1/4" pipe or 1.6250-12 UN-2B straight thread (1.250 tubing)

7 Maximum adjustable pressure

1 – 70 bar (1000 psi)
 2 – 140 bar (2000 psi)
 3 – 210 bar (3000 psi)*

* 10,3 bar (150 psi) pressure drop across valve minimum recommended. Not available with 'B' flow capacity.

8 Maximum rated flow capacity

B* – **Size** **Flow l/min (USgpm)**

03	26,5 (7)
06	57 (15)
10	189 (50)

 F – **Size** **Flow l/min (USgpm)**

03	53 (14)
06	114 (30)
10	284 (75)

 Blank – Omit for 'H' high-flow models

* Not available with '3' maximum adjustable pressure.

9 Design number

Subject to change. Installation dimensions same for designs 30 through 39.

Series X(C)*-03/06/10 Pressure Reducing Valves

General Data

The operation of these reducing valves is such that reduced outlet pressure remains constant regardless of variation of inlet pressure above the selected pressure setting. Reverse free flow from "reduced pressure outlet" connection to "high pressure inlet" connection is provided by optional integral check valve.

Contact your Vickers representative if maximum inlet pressure is needed with minimum rated reduced pressure.

Adjustment of reduced outlet pressure is accomplished by loosening jam nut and turning pressure adjustment control. Clockwise rotation increases pressure. Counterclockwise rotation decreases

pressure. Control adjustment has stops for minimum and maximum pressures.

Drain Connection

The drain connection must be piped directly to tank through a surge free line. Any continuous drain line pressure must be known and that value added to the valve pressure setting.

Pressure Adjustment

A differential of at least 10,3 bar (150 psi) between inlet and outlet pressure must be maintained for proper functioning.

Graphical Symbols

XS-**-*-30

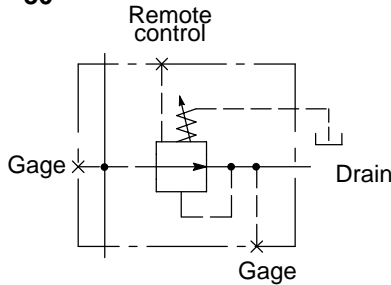

XCS-**-*-30

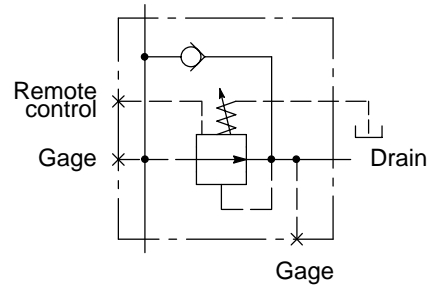

XG-**-*-30

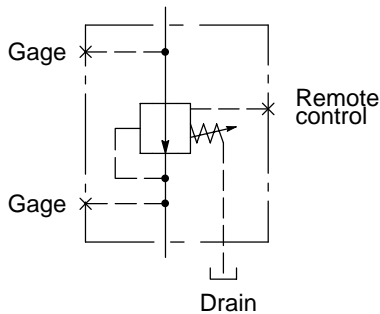

XCG-**-*-30

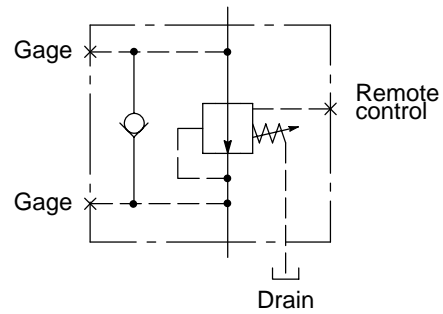

Series X(C)*-03/06/10 Pressure Reducing Valves

Performance Curves

Based on fluid with specific gravity of 0.865 and viscosity of 20 cSt (100 SUS)

Outlet Pressure vs. Flow

210 bar (3000 psi) inlet

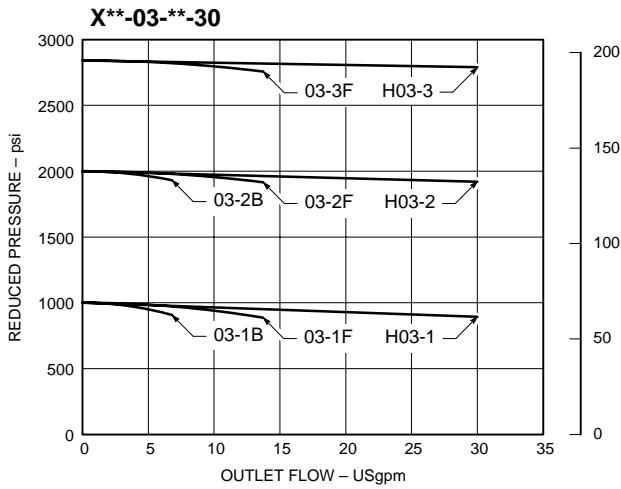

Valve Pressure Drop vs. Flow

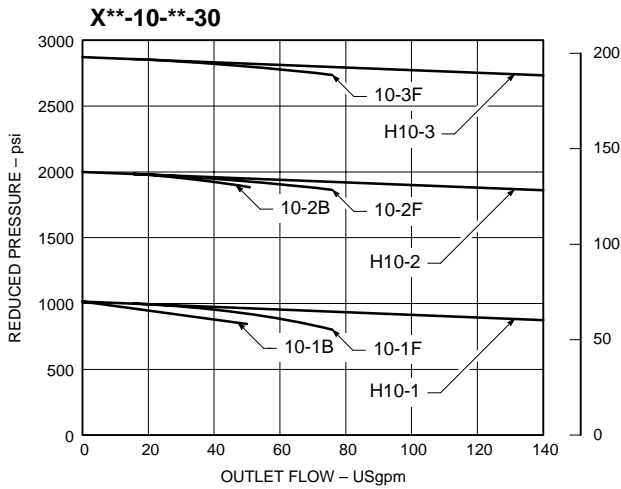
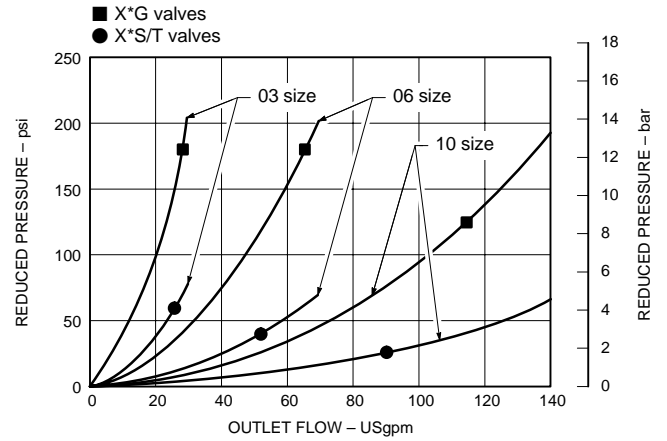

Check Valve Pressure Drop vs. Reverse Free Flow

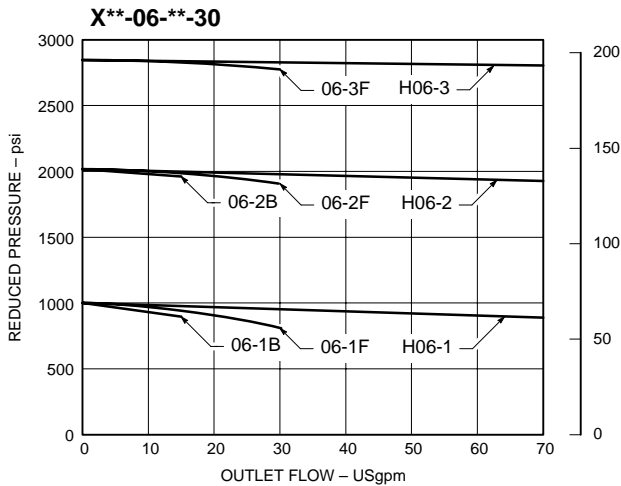
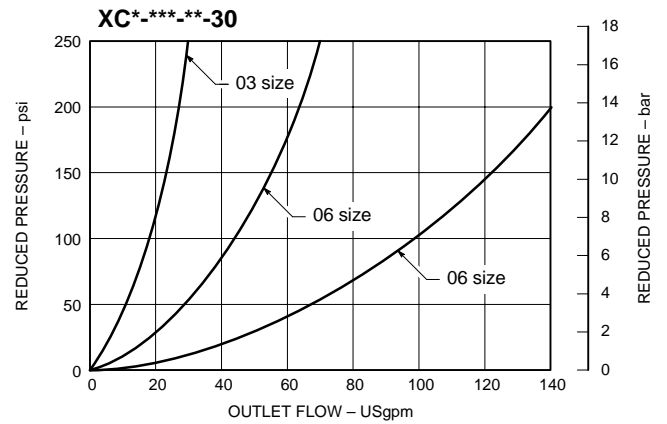

Drain (Control) Flow vs. Valve Pressure Drop (Inlet–Outlet) at Any Flow Condition

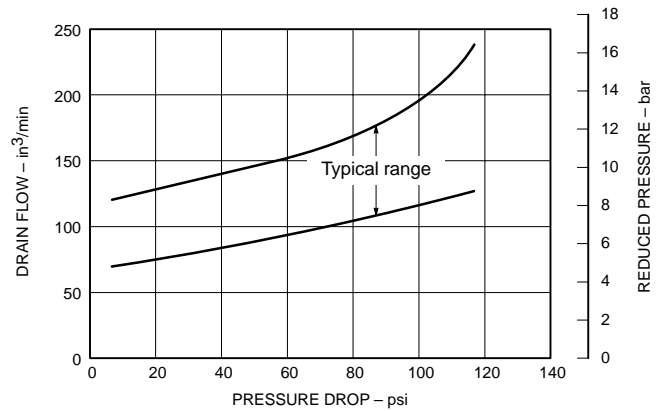

Series X(C)*-03/06/10 Pressure Reducing Valves

Minimum Adjustable Pressure vs. Flow

140 bar (2000 psi) inlet

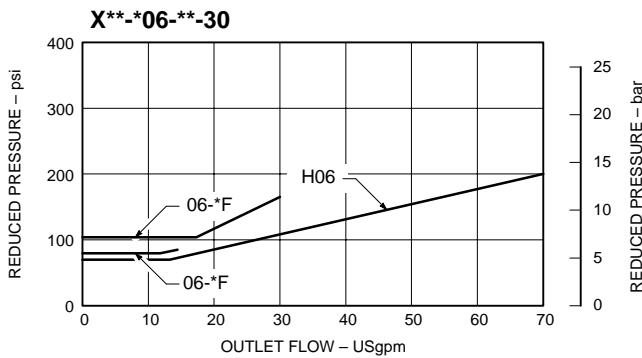
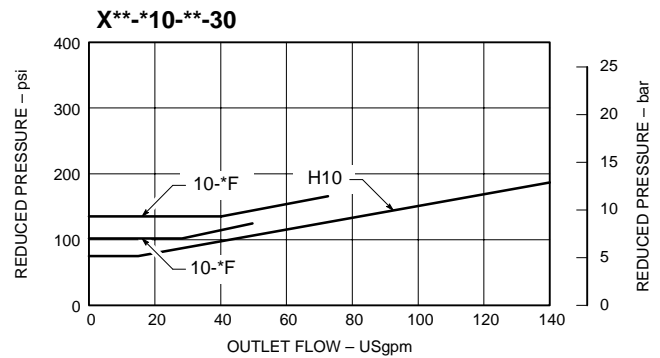
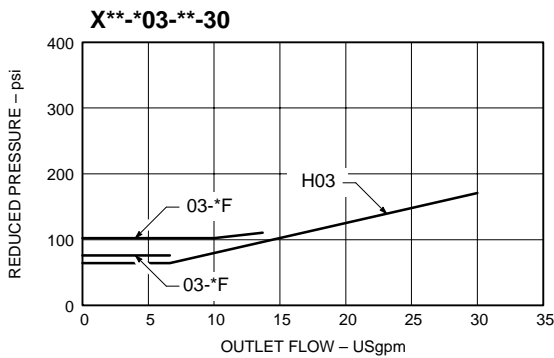

Valve Pressure Adjustment

Maximum pressure for each specific pressure range is pre-set at the factory with the large screw and held in place by the 1.125 hex nut.

Sensitivities for the different pressure ranges are: a) 185 psi/rev for 1000 psi max. pressure (5.4 turns total); b) 295 psi/rev for 2000 psi max. pressure (6.8 turns total); and c) 485 psi/rev for 3000 psi max. pressure (6.2 turns total). To lower the maximum pressure:

1. Start large screw approximately 2 to 3 turns into body, then assemble 1.125 hex nut, pressure adjustment control, and .562 jam nut.

2. Turn pressure adjustment control all the way in so .562 jam nut and pressure adjustment control head are tight against end of large screw.
 3. With 1.125 hex nut backed-off for clearance, continue turning pressure adjustment control (with large screw locked to it) until desired maximum pressure is reached.
 4. Tighten 1.125 hex nut against body to lock maximum pressure setting in place.
1. Back out pressure adjustment control to desired working pressure and lock in place with .562 jam nut.

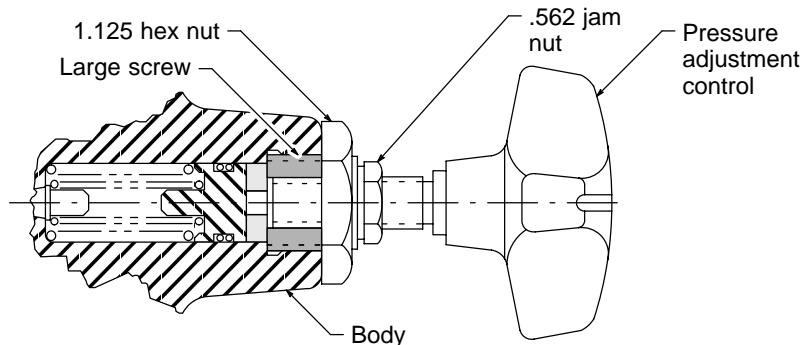

Series X(C)*-03/06/10 Pressure Reducing Valves

Installation Dimensions

Millimeters (inches)

Subplate or Manifold Mounted Models

XG-**-**-30 Without Check

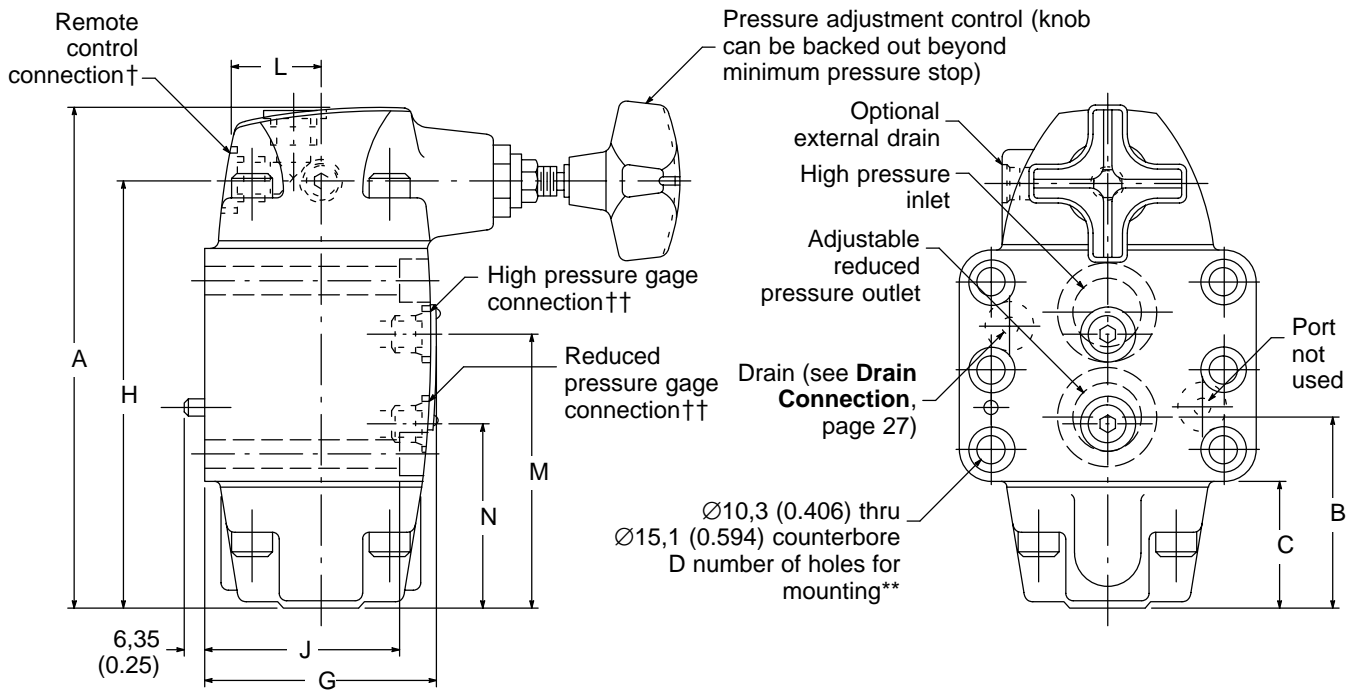
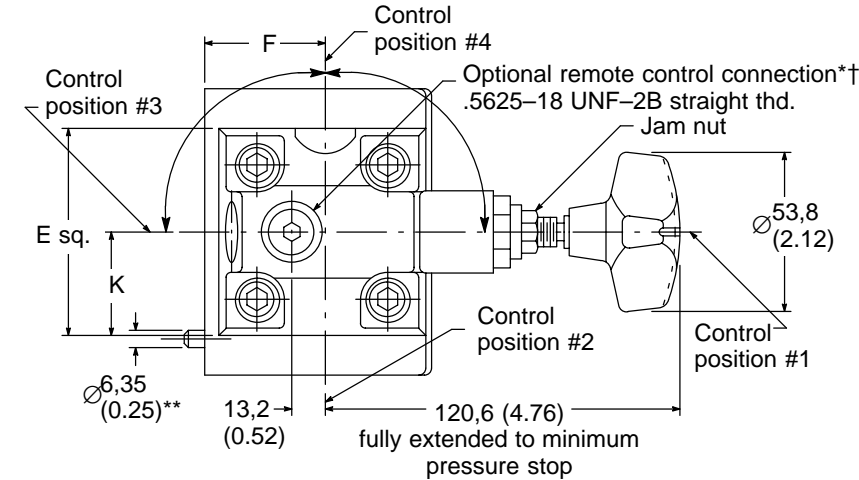

NOTES

Optional adjustment control positions obtained by rotating cover assembly. Position #1 is standard. Position #2 cannot be used. Position #3 can be used (if it does not interfere with the manifold) providing that the external drain in the cover is connected.

* Available with "(H)06" and "(H)10" models only.

** See mounting subplates for locating dimensions.

† .5625-18 UNF-2B straight thread. Reduced pressure may be adjusted remotely by connecting this port to pressure inlet port of CGR-02-*-20 valve or C-175-*-10 valve. Pressure setting of main valve must be higher than that of remote control.

†† .4375-20 UNF-2B straight thread.

Model	A	B	C	D	E	F	G	H	J	K	L	M	N	NFPA Interface
X(C)G-03-*-30	142,2 (5.60)	46,7 (1.84)	29,5 (1.16)	4	57,2 (2.25)	36,6 (1.44)	68,1 (2.68)	116,8 (4.60)	55,9 (2.20)	28,4 (1.12)	24,6 (0.97)	66,0 (2.60)	41,9 (1.65)	P03
X(C)G-06-*-30	176,5 (6.95)	66,8 (2.63)	44,7 (1.76)	4	71,4 (2.81)	41,1 (1.62)	79,2 (3.12)	151,1 (5.95)	68,6 (2.70)	35,8 (1.41)	29,5 (1.16)	96,8 (3.81)	65,0 (2.56)	P06
X(C)G-10-*-30	211,3 (8.32)	71,4 (2.81)	44,7 (1.76)	6	95,2 (3.75)	50,8 (2.00)	100,1 (3.94)	182,6 (7.19)	90,2 (3.55)	47,8 (1.88)	41,4 (1.63)	101,6 (4.00)	72,4 (2.85)	P10

Series X(C)*-03/06/10 Pressure Reducing Valves

Subplate or Manifold Mounted Models (continued)

XCG-**-**-30 With Check

(See previous page for other details and dimensions)

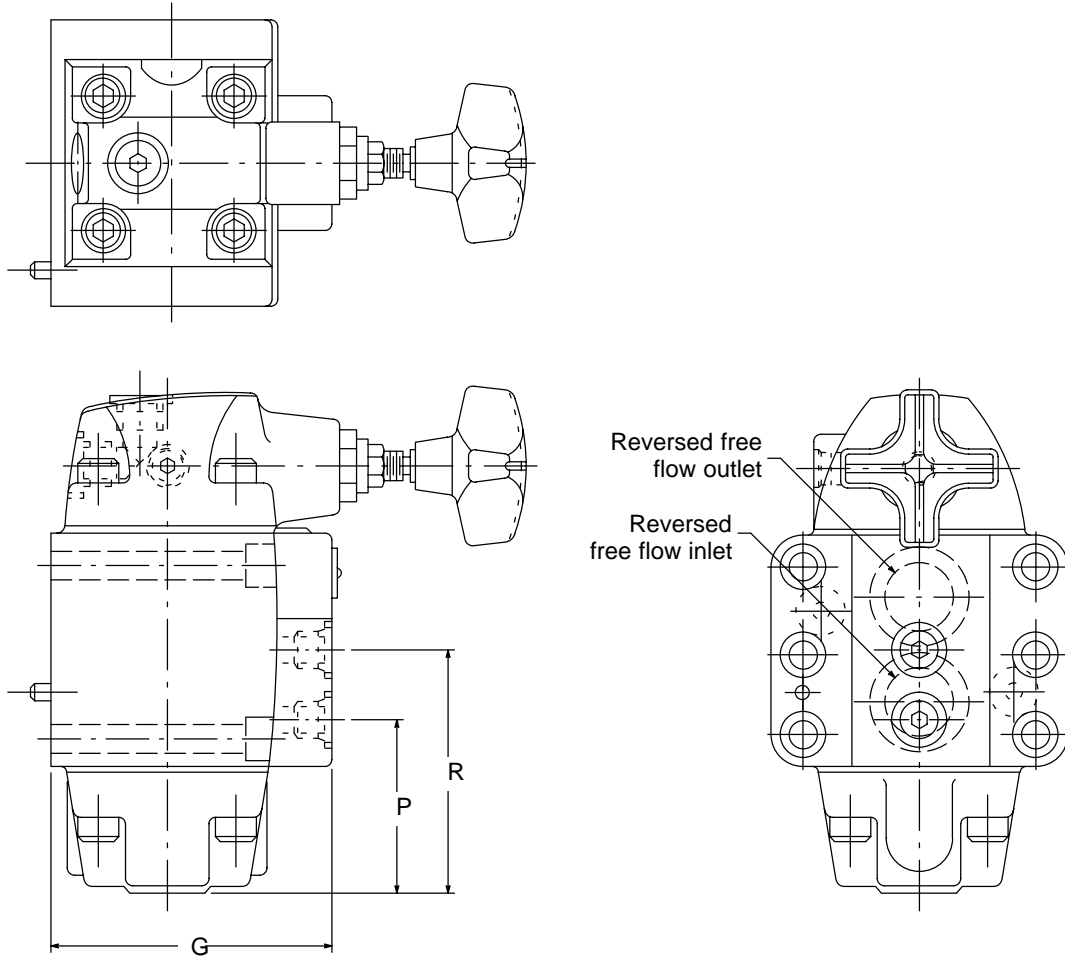

Model	G	P	R
XCG-03*-30	90,4 (3.56)	41,9 (1.65)	66,0 (2.60)
XCG-06*-30	98,6 (3.88)	59,7 (2.35)	85,9 (3.38)
XCG-10*-30	130,3 (5.13)	72,4 (2.85)	101,6 (4.00)

Series X(C)*-03/06/10 Pressure Reducing Valves

Threaded Port Models

XT- ** - * -30
Without Check

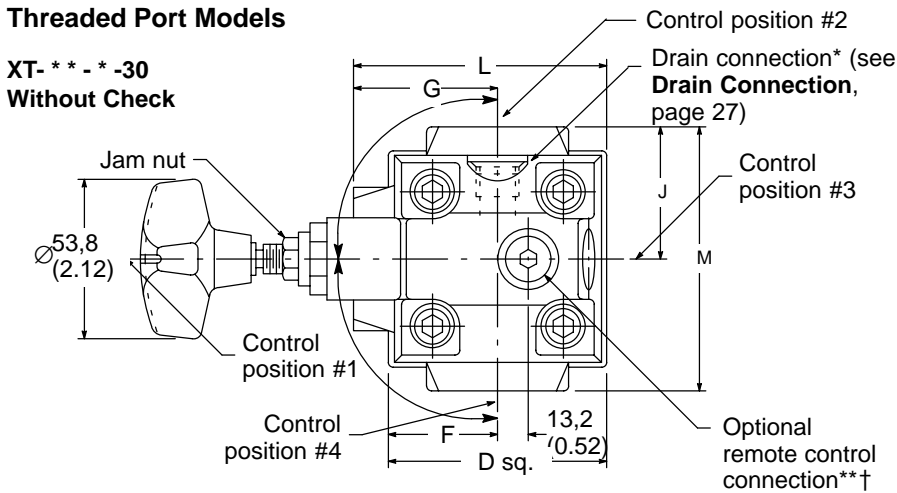

NOTES

Optional adjustment control positions obtained by rotating cover assembly. Position #1 is standard. Position #2 cannot be used on XS/T-10 models. Position #3 cannot be used.

* .5625-18 UNF-2B straight thread.

** Available with "(H)06" and "(H)10" models only.

† .5625-18 UNF-2B straight thread. Reduced pressure may be adjusted remotely by connecting this port to pressure inlet port of CGR-02*-20 valve or C-175*-10 valve. Pressure setting of main valve must be higher than that of remote control.

†† .4375-20 UNF-2B straight thread.

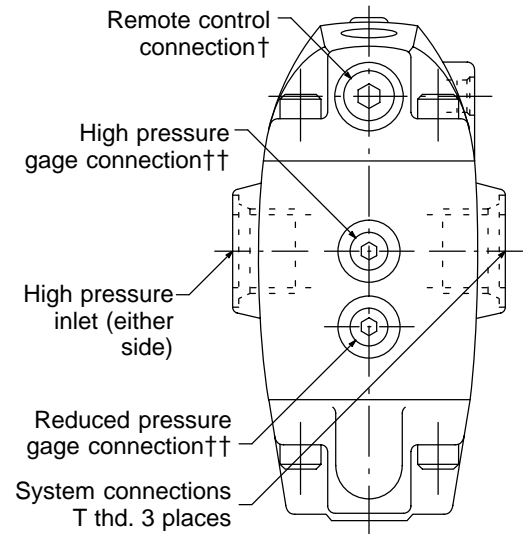
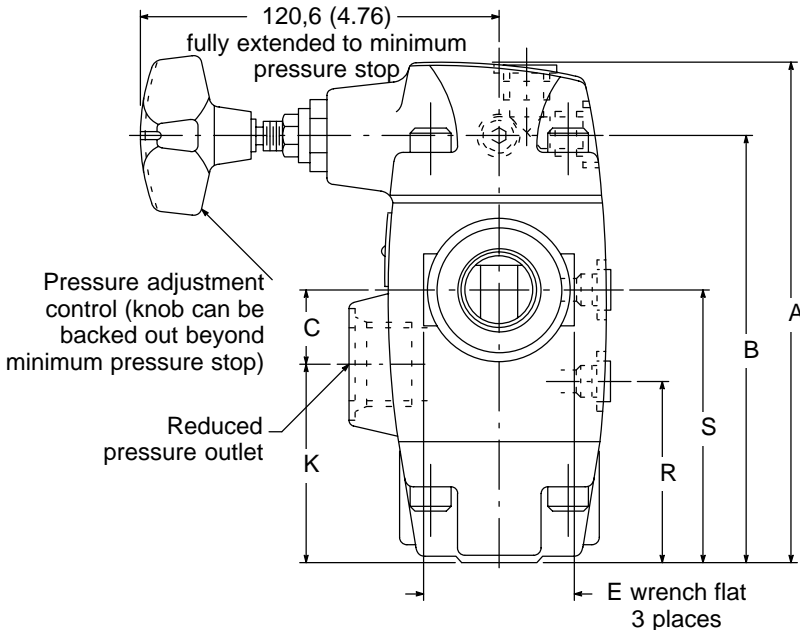

Model	A	B	C	D	E	F	G	H	J
X(C)S/T-03*-30	142,2 (5.60)	116,8 (4.60)	23,1 (0.91)	59,4 (2.34)	35,1 (1.38)	29,7 (1.17)	39,6 (1.56)	24,6 (0.97)	35,1 (1.38)
X(C)S/T-06*-30	176,5 (6.95)	151,1 (5.95)	26,9 (1.06)	74,7 (2.94)	50,8 (2.00)	37,3 (1.47)	50,8 (2.00)	29,5 (1.16)	47,8 (1.88)
X(C)S/T-10*-30	211,3 (8.32)	182,6 (7.19)	28,4 (1.12)	98,6 (3.88)	86,4 (3.40)	49,3 (1.94)	68,3 (2.69)	41,4 (1.63)	53,8 (2.12)

Model	K	L	M	R	S	T – for X(C)S models	T – for X(C)T models
X(C)S/T-03*-30	46,0 (1.81)	70,9 (2.79)	69,9 (2.75)	41,9 (1.65)	66,0 (2.60)	.7500–16 UNF–2B str thd. (1/2" O.D. tubing)	3/8" NPTF thd. ■
X(C)S/T-06*-30	69,8 (2.75)	88,1 (3.47)	95,3 (3.75)	65,0 (2.56)	96,8 (3.81)	1.0625–12 UNF–2B str thd. (3/4" O.D. tubing)	3/4" NPTF thd. ■
X(C)S/T-10*-30	81,0 (3.19)	117,3 (4.62)	108,0 (4.25)	72,4 (2.85)	101,6 (4.00)	1.6250–12 UNF–2B str thd. (1 1/4" O.D. tubing)	1 1/4" NPTF thd. ■

■ Not recommended

Series X(C)*-03/06/10 Pressure Reducing Valves

Threaded Port Models (continued)

XCS/T-**-**-30 With Check

(See previous page for other details and dimensions)

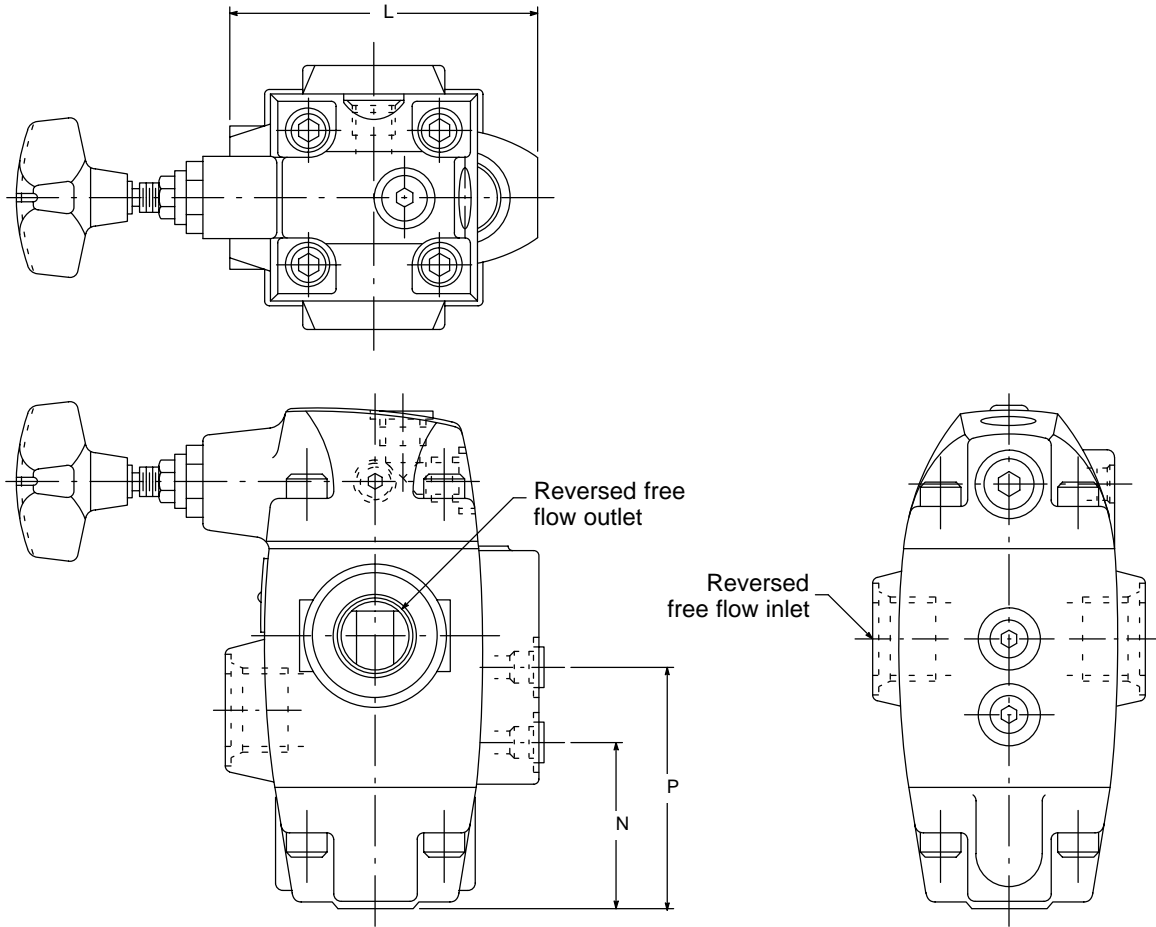

Model	L	N	P
XCS/T-03*-30	93,7 (3.69)	41,9 (1.65)	66,0 (2.60)
XCS/T-06*-30	108,0 (4.25)	59,7 (2.35)	84,6 (3.33)
XCS/T-10*-30	147,6 (5.81)	72,4 (2.85)	101,6 (4.00)

Series X(C)*-03/06/10 Pressure Reducing Valves

Mounting Subplates

When a subplate is not used, a machined pad (as indicated by shaded area) must be provided for mounting. The pad must be flat within 0,013 mm (0.0005 in) and smooth within 1,6 µm (63 microinch). Mounting bolts provided by the customer should be SAE grade 7 or better.

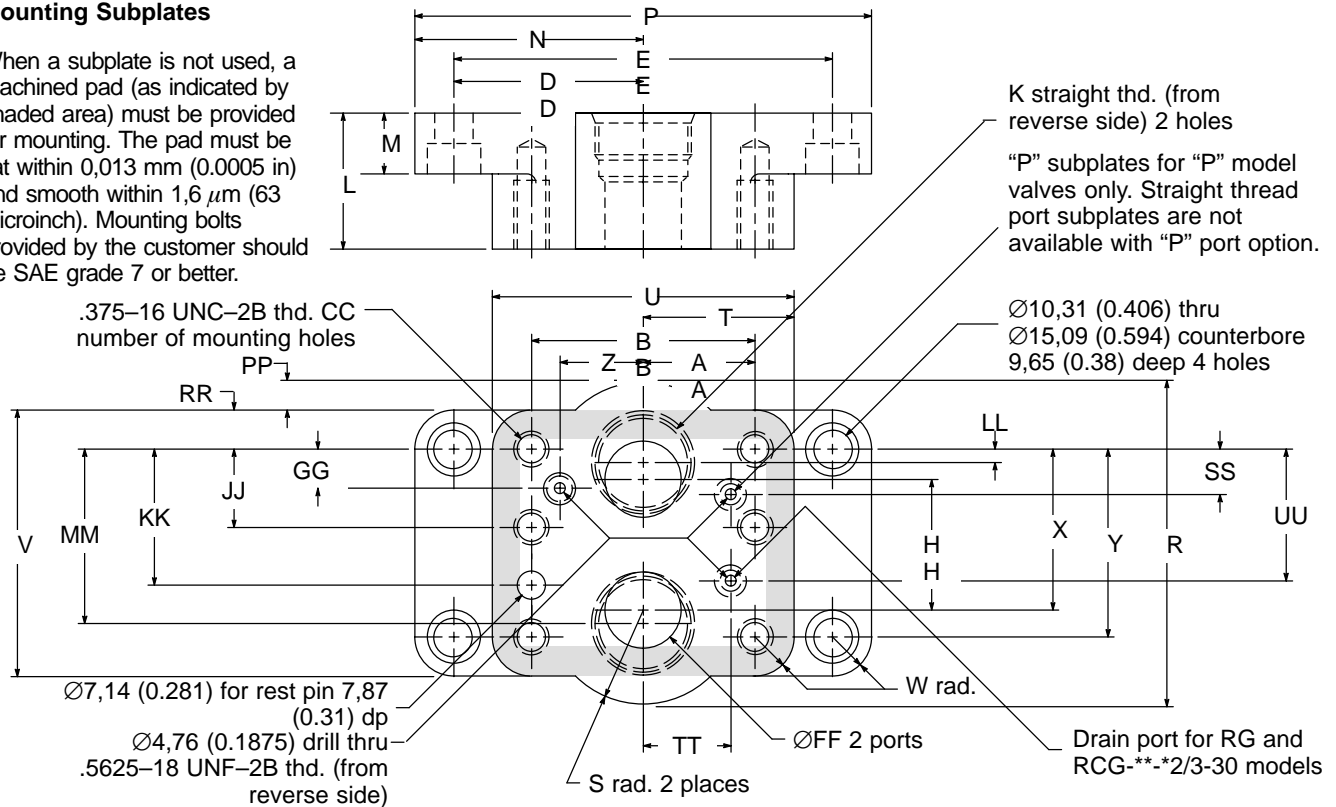

Model	K	Tube O.D.	L	M	N	P	R	S	T	U	V
RXGM-03S-(P)-20	.7500-16 UNF-2B	1/2"	25,4 (1.00)	19,0 (0.75)	63,5 (2.50)	127,0 (5.00)	76,2 (3.00)	23,9 (0.94)	43,7 (1.72)	87,4 (3.44)	63,5 (2.50)
RXGM-06SX-(P)-20	1.3125-1 2 UN-2B	1"	31,8 (1.25)	19,0 (0.75)	73,2 (2.88)	146,0 (5.75)	117,3 (4.62)	39,6 (1.56)	50,8 (2.00)	101,6 (4.00)	82,6 (3.25)
RXGM-10S-(P)-30	1.6250-1 2 UN-2B	1 1/4"	47,8 (1.88)	22,4 (0.88)	79,2 (3.12)	158,8 (6.25)	146,0 (5.75)	47,8 (1.88)	58,7 (2.31)	117,3 (4.62)	104,6 (4.12)

Model	W	X	Y (±0.005)	Z	AA	BB	CC	DD	EE (±0.013)	FF (±0.005)	GG
RXGM-03S-(P)-20	10,4 (0.41)	35,8 (1.41)	42,87 (1.688)	25,4 (1.00)	33,3 (1.31)	66,5 (2.62)	4	53,1 (2.09)	106,37 (4.188)	14,2 (0.56)	21,3 (0.84)
RXGM-06SX-(P)-20	10,2 (0.44)	49,3 (1.94)	60,32 (2.375)	33,3 (1.31)	39,6 (1.56)	79,2 (3.12)	4	62,0 (2.44)	123,82 (4.875)	23,1 (0.91)	20,6 (0.81)
RXGM-10S-(P)-30	10,4 (0.41)	67,6 (2.66)	84,12 (3.312)	44,4 (1.75)	48,5 (1.91)	96,8 (3.81)	6	69,1 (2.72)	138,12 (5.438)	28,4 (1.12)	24,6 (0.97)

Model	HH	JJ■	KK	LL	MM	PP	RR	SS	TT	UU	NFPA Interface
RXGM-03S-(P)-20	28,4 (1.12)	—	31,8 (1.25)	4,8 (0.19)	38,1 (1.50)	6,4 (0.25)	10,4 (0.41)	—	25,4 (1.00)	21,3 (0.84)	P03
RXGM-06SX-(P)-20	38,1 (1.50)	—	44,4 (1.75)	6,4 (0.25)	53,8 (2.12)	17,5 (0.69)	11,2 (0.44)	16,8 (0.66)	33,3 (1.31)	39,6 (1.56)	P06
RXGM-10S-(P)-30	50,8 (2.00)	42,2 (1.66)	62,7 (2.47)	7,9 (0.31)	76,2 (3.00)	20,6 (0.81)	10,4 (0.41)	24,6 (0.97)	44,4 (1.75)	59,4 (2.34)	P10

■ RXGM-03S/06SX require 4 valve mounting screws. RXGM-10S requires 6 valve mounting screws.

Application Data

Weights

The following table lists the approximate weight of each valve in the catalog:

Valve	Weight kg (lbs)
RS/T-03-*-30	2,7 (6.0)
RS/T-06-*-30	5,7 (12.5)
RS/T-10/12-*-30	12,0 (26.5)
RCS/T-03-*-30	2,9 (6.5)
RCS/T-06-*-30	5,9 (13.0)
RCS/T-10/12-*-30	12,9 (28.5)
RG-03-*-30	3,6 (8.0)
RG-06-*-30	6,4 (14.0)
RG-10/12-*-30	11,8 (26.0)
RCG-03-*-30	3,9 (8.5)
RCG-06-*-30	6,6 (14.5)
RCG-10/12-*-30	12,7 (28.0)
URT*-06-*-10	4,5 (10.0)
URT*-10-*-10	9,1 (20.0)
URG*-06-*-10	11,3 (25.0)
URG*-10-*-10	22,0 (48.5)
XS/TL-03-B-10	4,1 (9.0)
XGL-03-B-10	4,1 (9.0)
XG-03-*-30	3,9 (8.5)
XG-06-*-30	6,1 (13.5)
XG-10-*-30	11,8 (26.0)
XCG-03-*-30	4,1 (9.0)
XCG-06-*-30	6,4 (14.0)
XCG-10-*-30	12,2 (27.0)
XS/T-03-*-30	3,2 (7.0)
XS/T-06-*-30	5,7 (12.5)
XS/T-10-*-30	11,3 (25.0)
XCS/T-03-*-30	3,4 (7.5)
XCS/T-06-*-30	5,9 (13.0)
XCS/T-10-*-30	11,8 (26.0)

The following table lists the approximate weight of each subplate in the catalog:

Subplate	Weight kg (lbs)
RXGM-03S-20	1,5 (3.25)
RXGM-06SX-20	2,9 (6.50)
RXGM-10S-30	5,0 (11.00)
URG1M-06-10	5,7 (12.5)
URG1M-10-10	9,3 (20.5)
XGLM-10S-03-10	1,4 (3.0)

Fluids and Seals

For best results, oil viscosity should range between 32 cSt and 49 cSt (150 SUS and 225 SUS) at 38°C (100°F) with a maximum operating temperature of 68°C (155°F). Water glycol, water-in-oil emulsions, and petroleum oil may be used with non-F3 models, which are furnished with Buna-N seals for the mounting surface and fluorocarbon seals internally. Add F3 prefix when phosphate ester type fluids or blends are to be used. Refer to 694 for hydraulic fluid and temperature recommendations.

The use of synthetic, fire-resistant fluids requires a valve with special seals.

Subplates and Bolt Kits

Valves, subplates, and mounting bolts must be ordered separately.

Example:

- (1) URG*-06-12 valve
- (1) URG1M-06-10 subplate
- (1) BKUR06682 bolt kit (consisting of two bolts, $\frac{5}{8}$ -11 x 2.50", and four bolts, $\frac{5}{8}$ -11 x 5.25")

The following table lists the appropriate subplate for use with each manifold or subplate mounted valve in the catalog:

Valve	Subplate
RG-03-*-30	RXGM-03S-20
RG-06-*-30	RXGM-06SX-20
RG-10/12-*-30	RXGM-10S-30
RCG-03-*-30	RXGM-03S-20
RCG-06-*-30	RXGM-06SX-20
RCG-10/12-*-30	RXGM-10S-30
URG*-06-*-10	URG1M-06-10
URG*-10-*-10	URG1M-10-10
XGL-03-B-10	XGLM-10S-03-10
XG-03-*-30	RXGM-03S-20
XG-06-*-30	RXGM-06SX-20
XG-10-*-30	RXGM-10S-30
XCG-03-*-30	RXGM-03S-20
XCG-06-*-30	RXGM-06SX-20
XCG-10-*-30	RXGM-10S-30

The following table lists the appropriate bolt kit for each subplate mounted valve in the catalog:

Valve	Bolt Kit
R(C)G-03-*-30	BKRX03660
R(C)G-06-*-30	BKRX06661
R(C)G-10-*-30	BKRX10662
URG*-06-*-10	BKUR06682
URG*-10-*-10	BKUR10683
XGL-03-B-10	BKXL03663
X(C)G-03-*-30	BKRX03660
X(C)G-06-*-30	BKRX06661
X(C)G-10-*-30	BKRX10662

When a subplate is not used, a machined pad (as indicated by shaded area on subplate installation dimensions pages) must be provided for mounting. The pad must be flat within 0,013 mm (0.0005 in) and smooth within 1,6 μ m (63 microinch). Mounting bolts provided by the customer should be SAE grade 7 or better.

Application Data

Fluid Cleanliness

Proper fluid condition is essential for long and satisfactory life of hydraulic components and systems. Hydraulic fluid must have the correct balance of cleanliness, materials, and additives for protection against wear of components, elevated viscosity, and inclusion of air.

Essential information on the correct methods for treating hydraulic fluid is included in Vickers publication 561 "Vickers Guide to Systemic Contamination Control" available from your local Vickers distributor or by

contacting Vickers, Incorporated. Recommendations on filtration and the selection of products to control fluid condition are included in 561.

Recommended cleanliness levels, using petroleum oil under common conditions, are based on the highest fluid pressure levels in the system and are coded in the chart below. Fluids other than petroleum, severe service cycles, or temperature extremes are cause for adjustment of these cleanliness codes. See Vickers publication 561 for exact details.

Vickers products, as any components, will operate with apparent satisfaction in fluids with higher cleanliness codes than those described. Other manufacturers will often recommend levels above those specified. Experience has shown, however, that life of any hydraulic component is shortened in fluids with higher cleanliness codes than those listed below. These codes have been proven to provide a long, trouble-free service life for the products shown, regardless of the manufacturer.

Product	System Pressure Level bar (psi)		
	<70 (<1000)	70-207 (1000-3000)	207+ (3000+)
Vane Pumps – Fixed	20/18/15	19/17/14	18/16/13
Vane Pumps – Variable	18/16/14	17/15/13	
Piston Pumps – Fixed	19/17/15	18/16/14	17/15/13
Piston Pumps – Variable	18/16/14	17/15/13	16/14/12
Directional Valves	20/18/15	20/18/15	19/17/14
Pressure/Flow Control Valves	19/17/14	19/17/14	19/17/14
CMX Valves	18/16/14	18/16/14	17/15/13
Servo Valves	16/14/11	16/14/11	15/13/10
Proportional Valves	17/15/12	17/15/12	15/13/11
Cylinders	20/18/15	20/18/15	20/18/15
Vane Motors	20/18/15	19/17/14	18/16/13
Axial Piston Motors	19/17/14	18/16/13	17/15/12
Radial Piston Motors	20/18/14	19/17/13	18/16/13

Алматы (7273)495-231
Ангарск (3955)60-70-56
Архангельск (8182)63-90-72
Астрахань (8512)99-46-04
Барнаул (3852)73-04-60
Белгород (4722)40-23-64
Благовещенск (4162)22-76-07
Брянск (4832)59-03-52
Владивосток (423)249-28-31
Владикавказ (8672)26-90-48
Владимир (4922)49-43-18
Волгоград (844)278-03-48
Вологда (8172)26-41-59
Воронеж (473)204-51-73
Екатеринбург (343)384-55-89

Иваново (4932)77-34-06
Ижевск (3412)26-03-58
Иркутск (395)279-98-46
Казань (843)206-01-48
Калининград (4012)72-03-81
Калуга (4842)92-23-67
Кемерово (3842)65-04-62
Киров (8332)68-02-04
Коломна (4966)23-41-49
Кострома (4942)77-07-48
Краснодар (861)203-40-90
Красноярск (391)204-63-61
Курск (4712)77-13-04
Курган (3522)50-90-47
Липецк (4742)52-20-81

Магнитогорск (3519)55-03-13
Москва (495)268-04-70
Мурманск (8152)59-64-93
Набережные Челны (8552)20-53-41
Нижний Новгород (831)429-08-12
Новокузнецк (3843)20-46-81
Ноябрьск (3496)41-32-12
Новосибирск (383)227-86-73
Омск (3812)21-46-40
Орел (4862)44-53-42
Оренбург (3532)37-68-04
Пенза (8412)22-31-16
Петрозаводск (8142)55-98-37
Псков (8112)59-10-37
Пермь (342)205-81-47

Ростов-на-Дону (863)308-18-15
Рязань (4912)46-61-64
Самара (846)206-03-16
Санкт-Петербург (812)309-46-40
Саратов (845)249-38-78
Севастополь (8692)22-31-93
Саранск (8342)22-96-24
Симферополь (3652)67-13-56
Смоленск (4812)29-41-54
Сочи (862)225-72-31
Ставрополь (8652)20-65-13
Сургут (3462)77-98-35
Сыктывкар (8212)25-95-17
Тамбов (4752)50-40-97
Тверь (4822)63-31-35

Тольятти (8482)63-91-07
Томск (3822)98-41-53
Тула (4872)33-79-87
Тюмень (3452)66-21-18
Ульяновск (8422)24-23-59
Улан-Удэ (3012)59-97-51
Уфа (347)229-48-12
Хабаровск (4212)92-98-04
Чебоксары (8352)28-53-07
Челябинск (351)202-03-61
Череповец (8202)49-02-64
Чита (3022)38-34-83
Якутск (4112)23-90-97
Ярославль (4852)69-52-93

Россия +7(495)268-04-70

Казахстан +7(7172)727-132

Киргизия +996(312)96-26-47