

Алматы (7273)495-231  
 Ангарск (3955)60-70-56  
 Архангельск (8182)63-90-72  
 Астрахань (8512)99-46-04  
 Барнаул (3852)73-04-60  
 Белгород (4722)40-23-64  
 Благовещенск (4162)22-76-07  
 Брянск (4832)59-03-52  
 Владивосток (423)249-28-31  
 Владикавказ (8672)28-90-48  
 Владимир (4922)49-43-18  
 Волгоград (844)278-03-48  
 Вологда (8172)26-41-59  
 Воронеж (473)204-51-73  
 Екатеринбург (343)384-55-89

Иваново (4932)77-34-06  
 Ижевск (3412)26-03-58  
 Иркутск (395)279-98-46  
 Казань (843)206-01-48  
 Калининград (4012)72-03-81  
 Калуга (4842)92-23-67  
 Кемерово (3842)65-04-62  
 Киров (8332)68-02-04  
 Коломна (4966)23-41-49  
 Кострома (4942)77-07-48  
 Краснодар (861)203-40-90  
 Красноярск (391)204-63-61  
 Курск (4712)77-13-04  
 Курган (3522)50-90-47  
 Липецк (4742)52-20-81

Магнитогорск (3519)55-03-13  
 Москва (495)268-04-70  
 Мурманск (8152)59-64-93  
 Набережные Челны (8552)20-53-41  
 Нижний Новгород (831)429-08-12  
 Новокузнецк (3843)20-46-81  
 Ноябрьск (3496)41-32-12  
 Новосибирск (383)227-86-73  
 Омск (3812)21-46-40  
 Орел (4862)44-53-42  
 Оренбург (3532)37-68-04  
 Пенза (8412)22-31-16  
 Петрозаводск (8142)55-98-37  
 Псков (8112)59-10-37  
 Пермь (342)205-81-47

Ростов-на-Дону (863)308-18-15  
 Рязань (4912)46-61-64  
 Самара (846)206-03-16  
 Санкт-Петербург (812)309-46-40  
 Саратов (845)249-38-78  
 Севастополь (8692)22-31-93  
 Саранск (8342)22-96-24  
 Симферополь (3652)67-13-56  
 Смоленск (4812)29-41-54  
 Сочи (862)225-72-31  
 Ставрополь (8652)20-65-13  
 Сургут (3462)77-98-35  
 Сыктывкар (8212)25-95-17  
 Тамбов (4752)50-40-97  
 Тверь (4822)63-31-35

Тольятти (8482)63-91-07  
 Томск (3822)98-41-53  
 Тула (4872)33-79-87  
 Тюмень (3452)66-21-18  
 Ульяновск (8422)24-23-59  
 Улан-Удэ (3012)59-97-51  
 Уфа (347)229-48-12  
 Хабаровск (4212)92-98-04  
 Чебоксары (8352)28-53-07  
 Челябинск (351)202-03-61  
 Череповец (8202)49-02-64  
 Чита (3022)38-34-83  
 Якутск (4112)23-90-97  
 Ярославль (4852)69-52-93

Россия +7(495)268-04-70

Казахстан +7(7172)727-132

Киргизия +996(312)96-26-47

<https://vickers.nt-rt.ru> || [vsh@nt-rt.ru](mailto:vsh@nt-rt.ru)

# Flow Controls, One Way Restrictor Type

## FN-03; EFN-06 and EFN-10

### Typical Section

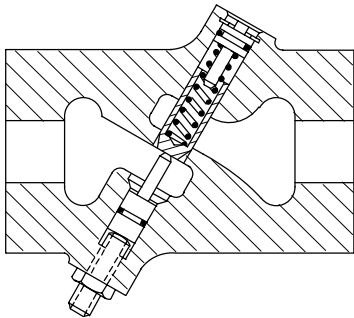

### Functional Symbol

All models

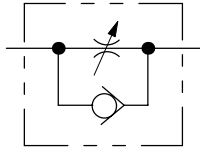

### Model Code

**F3 - (E) FN- \*\* - \*\* - \***

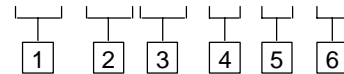

#### 1 Special seals

For use with phosphate ester type fluids  
 Omit if not required

#### 2 European product

Omit for FN-03

#### 3 Flow control, one-way restrictor type

#### 4 Nominal size

03 = 3/8"  
 06 = 3/4"  
 10 = 1 1/4"

#### 5 Design number

11 = EFN-10  
 20 = FN-03  
 21 = EFN-06

#### 6 System connections

B = G (BSPF)  
 F = SAE 4-bolt flange  
 (EFN-06/10 only)

### Basic Characteristics

Type ..... Restrictor valve  
 Mounting ..... Thread or flange  
 Maximum pressure ..... Up to 210 bar (3000 psi)  
 Maximum flow ..... Up to 190 L/min (50 USgpm)  
 Method of Adjustment ..... Manual

### General Description

The FN-03 and EFN-06/10 adjustable one-way restrictors are designed for applications where fluid oil flow regulation without pressure compensation is required. They can be used whenever the working load remains relatively constant.

# Operating Data

## Maximum Pressure bar (psi)

Hydraulic petroleum oils and common FR fluids ..... 210 (3000)  
 5% – 95% oil-in-water emulsion ..... 140 (2000)

## Flow/Pressure Data

Maximum recommended controlled flow, L/min (USgpm), with good regulation.  
 FN-03 ..... 38 (10)  
 EFN-06 ..... 76 (20)  
 EFN-10 ..... 189 (50)

## Minimum Controlled Flow

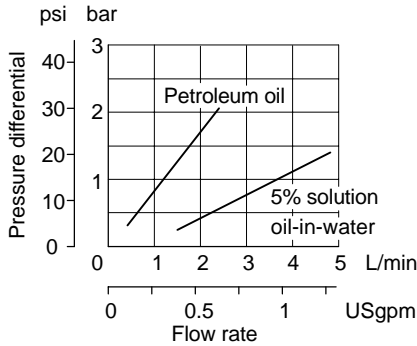

## Pressure Drop for Free-Flow and Maximum Controlled Flow

Models FN-03 and EFN-06

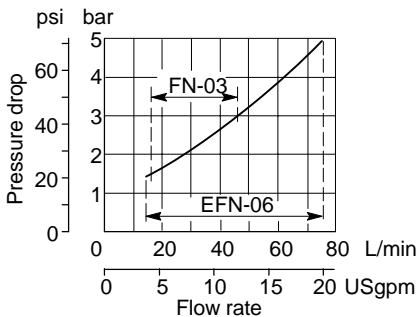

Model EFN-10

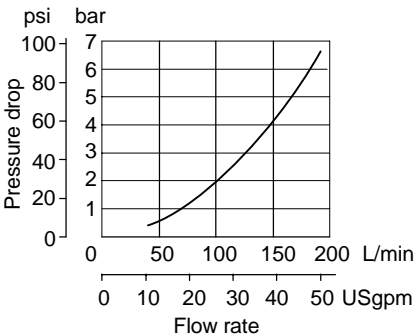

## Hydraulic Fluids

All models can be used with hydraulic oils, water-in-oil emulsions and water glycols. Add prefix "F3" to model designation when phosphate ester (not alkyl-based) to be used. EFN-06 and 10 models can also be used with a 5-10% concentration of soluble oil in clean water.

The extreme operating viscosity range is from 13 to 860 cSt (70 to 4000 SUS) but the recommended running range for all but soluble-oil-in-water emulsions is 13 to 54 cSt (70 to 245 SUS).

For further information about fluids see leaflet 920.

## Contamination Control Requirements

Recommendations on contamination control methods and the selection of products to control fluid condition are included in Vickers publication 9132 or 561, "Vickers Guide to Systemic Contamination Control". The book also includes information on the Vickers concept of "ProActive Maintenance". The following recommendations are based on ISO cleanliness levels at 2 µm, 5 µm and 15 µm. For products in this catalog the recommended levels are:

Up to 210 bar (3000 psi) ..... 19/17/14

## Temperature Limits

### Ambient

Min. .... -20°C (-4°F)  
 Max. .... +40°C (+104°F)

### Fluid Temperature

	Petroleum oil	Water-containing
Min.	-20°C (-4°F)	+10°C (+50°F)
Max.*	+80°C (+176°F)	+54°C (+130°F)

\* To obtain optimum service life from both fluid and hydraulic system 65°C (150°F) normally is the maximum temperature except for water-containing fluids.

For synthetic fluids consult manufacturer or Vickers representative where limits are outside those for petroleum use. Whatever the actual temperature range, ensure that viscosities stay within the limits specified in the "Hydraulic Fluids" section.

## Installation Dimensions in mm (inches)

### EFN-06 and EFN-10

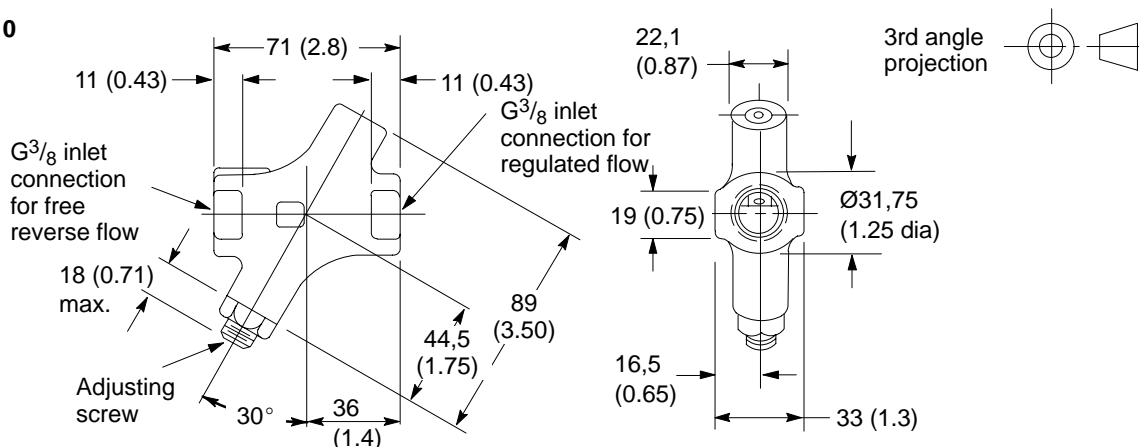

### FN-03

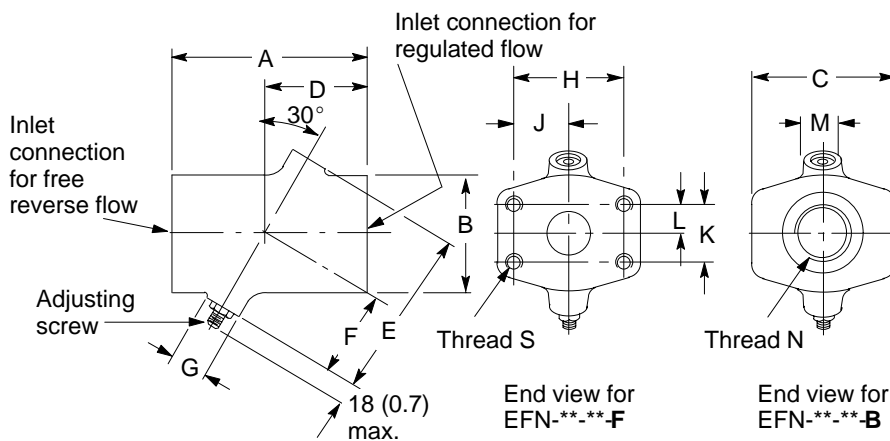

Model	A	B	C	D	E	F	G	H	J	K	L	M
EFN-06-21-F	89 (3.50)	52 (2.04)	65 (2.56)	45 (1.77)	90 (3.54)	44,5 (1.75)	22 (0.87)	47,6 (1.87)	23,9 (0.94)	22,1 (0.87)	11 (0.43)	22 (0.87)
EFN-06-21-B	89 (3.50)	52 (2.04)	65 (2.56)	45 (1.77)	90 (3.54)	44,5 (1.75)	22 (0.87)	—	—	—	—	22 (0.87)
EFN-10-11-F	116 (4.57)	73 (2.87)	80 (3.15)	58 (2.28)	100 (3.94)	47 (1.85)	25 (0.98)	58,7 (2.31)	29,4 (1.16)	30,2 (1.19)	15 (0.59)	32 (1.26)
EFN-10-11-B	116 (4.57)	73 (2.87)	80 (3.15)	58 (2.28)	100 (3.94)	47 (1.85)	25 (0.98)	—	—	—	—	32 (1.26)

Model	Thread N	SAE flange sizes		Thread S
		Nom. bore	Pipe O.D.	
EFN-06-21-F	—	3/4"	25	3/8"-16 UNC-2B x 19 (0.75) deep
EFN-10-11-F	—	1 1/4"	38	7/16"-14 UNC x 19 (0.75) deep

### Mass, kg (lb)

FN-03-20	0,6 (1.3)
EFN-06-21	1,7 (3.7)
EFN-10-11	3,7 (8.1)

### Ordering Procedure

SAE 4-bolt flanges for the appropriate valves are available from Vickers and must be ordered as, and are supplied as, separate items.

### Mounting Attitude

Optional.

Алматы (7273)495-231  
Ангарск (3955)60-70-56  
Архангельск (8182)63-90-72  
Астрахань (8512)99-46-04  
Барнаул (3852)73-04-60  
Белгород (4722)40-23-64  
Благовещенск (4162)22-76-07  
Брянск (4832)59-03-52  
Владивосток (423)249-28-31  
Владикавказ (8672)28-90-48  
Владимир (4922)49-43-18  
Волгоград (844)278-03-48  
Вологда (8172)26-41-59  
Воронеж (473)204-51-73  
Екатеринбург (343)384-55-89

Иваново (4932)77-34-06  
Ижевск (3412)26-03-58  
Иркутск (395)279-98-46  
Казань (843)206-01-48  
Калининград (4012)72-03-81  
Калуга (4842)92-23-67  
Кемерово (3842)65-04-62  
Киров (8332)68-02-04  
Коломна (4966)23-41-49  
Кострома (4942)77-07-48  
Краснодар (861)203-40-90  
Красноярск (391)204-63-61  
Курск (4712)77-13-04  
Курган (3522)50-90-47  
Липецк (4742)52-20-81

Магнитогорск (3519)55-03-13  
Москва (495)268-04-70  
Мурманск (8152)59-64-93  
Набережные Челны (8552)20-53-41  
Нижний Новгород (831)429-08-12  
Новокузнецк (3843)20-46-81  
Ноябрьск (3496)41-32-12  
Новосибирск (383)227-86-73  
Омск (3812)21-46-40  
Орел (4862)44-53-42  
Оренбург (3532)37-68-04  
Пенза (8412)22-31-16  
Петрозаводск (8142)55-98-37  
Псков (8112)59-10-37  
Пермь (342)205-81-47

Ростов-на-Дону (863)308-18-15  
Рязань (4912)46-61-64  
Самара (846)206-03-16  
Санкт-Петербург (812)309-46-40  
Саратов (845)249-38-78  
Севастополь (8692)22-31-93  
Саранск (8342)22-96-24  
Симферополь (3652)67-13-56  
Смоленск (4812)29-41-54  
Сочи (862)225-72-31  
Ставрополь (8652)20-65-13  
Сургут (3462)77-98-35  
Сыктывкар (8212)25-95-17  
Тамбов (4752)50-40-97  
Тверь (4822)63-31-35

Тольятти (8482)63-91-07  
Томск (3822)98-41-53  
Тула (4872)33-79-87  
Тюмень (3452)66-21-18  
Ульяновск (8422)24-23-59  
Улан-Удэ (3012)59-97-51  
Уфа (347)229-48-12  
Хабаровск (4212)92-98-04  
Чебоксары (8352)28-53-07  
Челябинск (351)202-03-61  
Череповец (8202)49-02-64  
Чита (3022)38-34-83  
Якутск (4112)23-90-97  
Ярославль (4852)69-52-93

Россия +7(495)268-04-70

Казахстан +7(7172)727-132

Киргизия +996(312)96-26-47

<https://vickers.nt-rt.ru> || [vsh@nt-rt.ru](mailto:vsh@nt-rt.ru)