

Алматы (7273)495-231
 Ангарск (3955)60-70-56
 Архангельск (8182)63-90-72
 Астрахань (8512)99-46-04
 Барнаул (3852)73-04-60
 Белгород (4722)40-23-64
 Благовещенск (4162)22-76-07
 Брянск (4832)59-03-52
 Владивосток (423)249-28-31
 Владикавказ (8672)28-90-48
 Владимир (4922)49-43-18
 Волгоград (844)278-03-48
 Вологда (8172)26-41-59
 Воронеж (473)204-51-73
 Екатеринбург (343)384-55-89

Иваново (4932)77-34-06
 Ижевск (3412)26-03-58
 Иркутск (395)279-98-46
 Казань (843)206-01-48
 Калининград (4012)72-03-81
 Калуга (4842)92-23-67
 Кемерово (3842)65-04-62
 Киров (8332)68-02-04
 Коломна (4966)23-41-49
 Кострома (4942)77-07-48
 Краснодар (861)203-40-90
 Красноярск (391)204-63-61
 Курск (4712)77-13-04
 Курган (3522)50-90-47
 Липецк (4742)52-20-81

Магнитогорск (3519)55-03-13
 Москва (495)268-04-70
 Мурманск (8152)59-64-93
 Набережные Челны (8552)20-53-41
 Нижний Новгород (831)429-08-12
 Новокузнецк (3843)20-46-81
 Ноябрьск (3496)41-32-12
 Новосибирск (383)227-86-73
 Омск (3812)21-46-40
 Орел (4862)44-53-42
 Оренбург (3532)37-68-04
 Пенза (8412)22-31-16
 Петрозаводск (8142)55-98-37
 Псков (8112)59-10-37
 Пермь (342)205-81-47

Ростов-на-Дону (863)308-18-15
 Рязань (4912)46-61-64
 Самара (846)206-03-16
 Санкт-Петербург (812)309-46-40
 Саратов (845)249-38-78
 Севастополь (8692)22-31-93
 Саранск (8342)22-96-24
 Симферополь (3652)67-13-56
 Смоленск (4812)29-41-54
 Сочи (862)225-72-31
 Ставрополь (8652)20-65-13
 Сургут (3462)77-98-35
 Сыктывкар (8212)25-95-17
 Тамбов (4752)50-40-97
 Тверь (4822)63-31-35

Тольятти (8482)63-91-07
 Томск (3822)98-41-53
 Тула (4872)33-79-87
 Тюмень (3452)66-21-18
 Ульяновск (8422)24-23-59
 Улан-Удэ (3012)59-97-51
 Уфа (347)229-48-12
 Хабаровск (4212)92-98-04
 Чебоксары (8352)28-53-07
 Челябинск (351)202-03-61
 Череповец (8202)49-02-64
 Чита (3022)38-34-83
 Якутск (4112)23-90-97
 Ярославль (4852)69-52-93

Россия +7(495)268-04-70

Казахстан +7(7172)727-132

Киргизия +996(312)96-26-47

<https://vickers.nt-rt.ru> || vsh@nt-rt.ru

Solenoid Operated Poppet-Type Directional Control Valves

Cartridge Models CVUA-6-PD
 Gasket Mounted Models DG3/4VP-3

Construction of a Typical
 3 Way/2 Position Cartridge Type
 Valve, Model CVUA-6-PDN-3-M-U

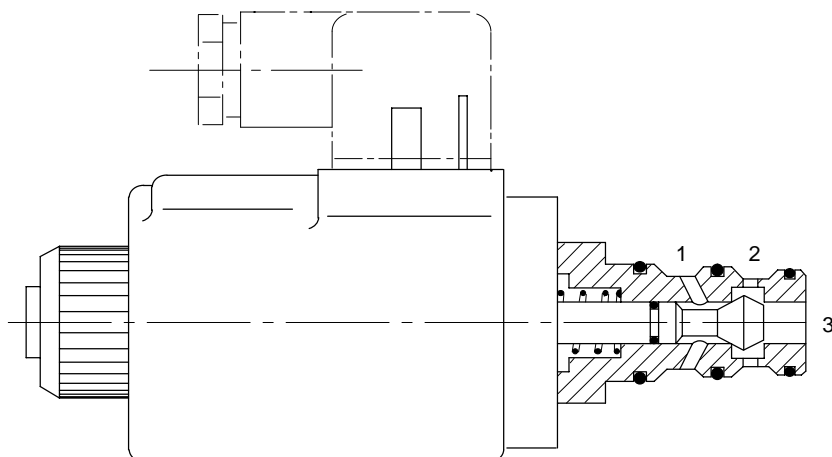

Functional Symbols

CVUA-6-PD*-2

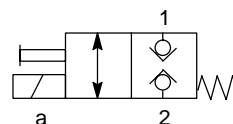

CVUA-6-PD*-3

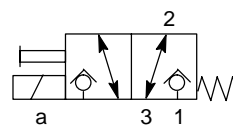

DG3VP-3-102A

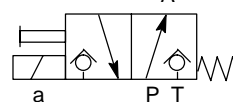

DG3VP-3-103A

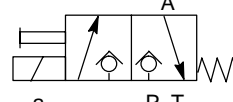

DG4VP-3-104C

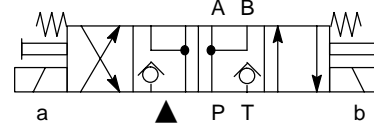

DG4VP-3-105C

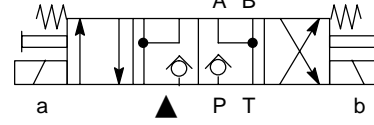

▲ This spool position is achieved only when both solenoids are energized simultaneously and remain so.

Note: No leakage in either direction
 Through flow in both directions

Basic Characteristics

Max. pressure 315 bar (4500 psi)
 Max. flow rates Up to 20 L/min
 (32 USgpm)

Mounting surface for
 DG*VP models ISO 4401 size O3
 NFPA D01
 DIN 24340 (NG6)

General Description

These new solenoid operated poppet valves are used mainly for starting, stopping and controlling the direction of linear and rotary actuators or for use as a pilot valve. The gasket mounted types can also be used for controlling the pilot functions of cartridge valves to ISO 7368 (DIN 24342) (see catalog 2378).

All valves are of a "zero leakage design" which is the major design feature of poppet-type valves. The valves are available as either gasket mounted or cartridge insert type. The latter requires a housing having a purpose-formed recess (see recess hole drawing and special tool note).

Advantages

- Zero internal leakage in closed position
- Fast consistent response times
- Cost-efficient high pressure capability
- Simple assembly and installation
- Fast and easy servicing

Model Codes

For CVUA Cartridge Valves

(F3-)CVUA-6-PD * - * -M-U-* -1*

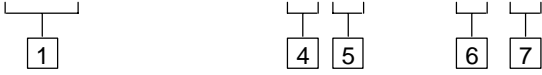

For DG*VP Valves

(F3-)DG * VP-3-10 -VM-U-* -1***

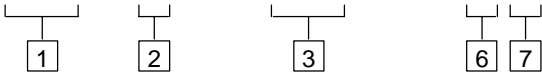

1 Prefix, fluid compatibility

Blank = For petroleum oils, water glycols and invert emulsions
 F3 = For phosphate esters, petroleum oils, water glycols and invert emulsions

2 Function

3 = Three-way
 4 = Four-way

3 Spool and spring arrangement

102A = Normally open, spring offset; option for DG3VP models
 103A = Normally closed, spring offset; option for DG3VP models
 104C = Normally open, spring centered; option for DG4VP models
 105C = Normally closed, spring centered; option for DG4VP models

4 Mounting flange type

N = Narrow thickness flange
 W = Wide thickness flange

5 Function

2 = Two-way
 3 = Three-way

6 Coil rating

B = 110 V AC 50/115 V AC 60
 D = 220 V AC 50/230 V AC 60
 G = 12 V DC
 H = 24 V DC

7 Design number, 10 series

Subject to change. Installation dimensions unaltered for design numbers 10 to 19 inclusive.

For Electrical Plugs

See "Installation Dimensions" section.

For Tool Kits for CVUA Valves

See "Installation Dimensions" section.

For Mounting Subplates and Bolt Kits for DG*VP Models

See catalogs 2425 and 2314.

Note: CVUA valves are supplied complete with mounting flanges and metric fixing bolts.

Operating Data

Pressure and Flow Limits

Max. Pressure

Non-F3-Prefix Models:

For < 10 switching cycles/min 315 bar (4500 psi)
 For 10 to 180 switching cycles/min 210 bar (3000 psi)

F3-Prefix Models:

Up to 180 switching cycles/min 210 bar (3000 psi)

Note: For all valves lower limits may apply if high-water-based fluids (e.g. 5%/95% oil-in-water emulsions) are to be used; contact your Vickers representative.

Max. Flow Rate Up to 20 L/min (5.3 USgpm)

Control Data

Rated Power Supply

See "Model Codes" section.

Power Consumption, AC Solenoids

Inrush, max. ▲ VA 396
 Steady-state ▼ VA 198
 Holding VA 57
 All above values are RMS

▲ *Armature fully retracted, 1st half-cycle.*
 ▼ *At start of normal working stroke of valve spool. Previously called "Inrush".*

Power Consumption, DC Solenoids

At rated voltage and wire temperature of 20°C (68°F) 38W

Relative Duty Factor

100% continuous rating

Type of Protection

Weatherproof to IEC 144 Class IP65
 Winding insulation to Class H
 Epoxy resin to Class F

Permissible Voltage Fluctuation

± 5% of rated voltage

Performance Data

Pressure Drop Data

Typical with hydraulic petroleum oil at 36 cSt (170 SUS) and at 50°C (122°F)

CVUA-6-PD*-3 Models

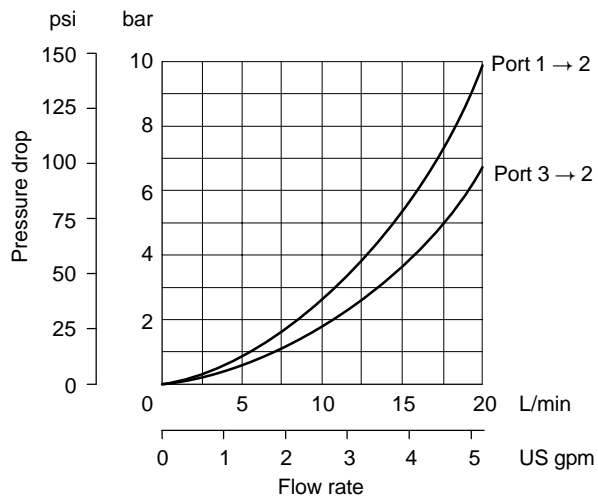

CVUA-6-PD*-2 Models

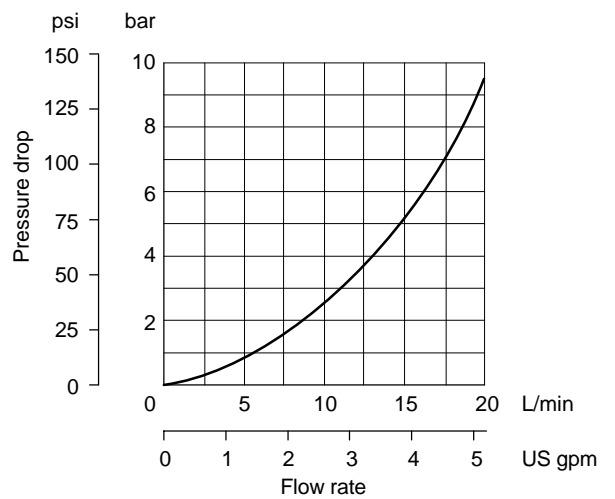

DG3VP-3 and DG4VP-3 Models

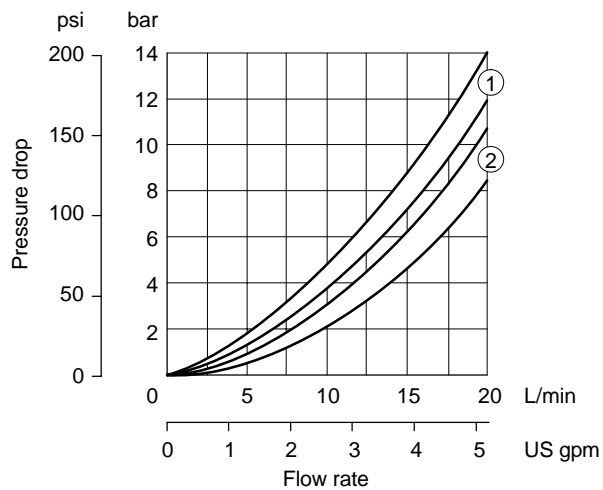

Model	Curve for flow:			
	P to A	P to B	A to T	B to T
DG3VP-3-102A	②	—	①	—
DG3VP-3-103A	①	—	②	—
DG4VP-3-104C	②	②	①	①
DG4VP-3-105C	①	①	②	②

Response Times

Time taken from when signal is first applied at solenoid until armature completes its travel. Based on average conditions with warm solenoids at 95% rated voltage:

AC and DC energizing 150 ms
AC and DC* de-energizing 85 ms

* *In pure switched circuit conditions devoid of the effects of any suppression diodes and full-wave rectifiers.*

Hydraulic Fluids

All valves can be used with anti-wear hydraulic oils, water-in-oil emulsions and water glycols. Add prefix "F3" to model designation when phosphate ester (not alkyl-based) or chlorinated hydrocarbons are to be used.

The valves are also suitable for use with high water-based fluids (95% water, 5% oil) up to 200 bar.

The extreme operating viscosity range is from 300 to 13 cSt (1460 to 70 SUS) but the recommended running range is 54 to 13 cSt (250 to 70 SUS).

For further information about fluids see catalog 920.

Temperature Limits

Ambient min. -20°C (-4°F)
Ambient max. +70°C (158°F)

Fluid temperature

	Petroleum oil	Water-containing
Min.	-20°C (-4°F)	+10°C (+50°F)
Max.*	+70°C (+158°F)	+54°C (+130°F)

* *To obtain optimum service life from both fluid and hydraulic system, 65°C (150°F) normally is the maximum temperature except for water-containing fluids.*

For synthetic fluids consult manufacturer and your Vickers representative where limits are outside those for petroleum oil.

Whatever the actual temperature range, ensure that viscosities stay within the limits specified in the "Hydraulic Fluids" section.

Contamination Control Requirements

Recommendations on contamination control methods and the selection of products to control fluid condition are included in Vickers publication 9132 or 561, "Vickers Guide to Systemic Contamination Control". The book also includes information on the Vickers concept of "ProActive Maintenance". The following recommendations are based on ISO cleanliness levels at 2 µm, 5 µm and 15 µm. For products in this catalog the recommended levels are:

Up to 210 bar (3050 psi) 20/18/15
Above 210 bar (3050 psi) 19/17/14

Installation Dimensions in mm (inches)

Model Types:
CVUA-6-PDN-2 and CVUA-6-PDW-2

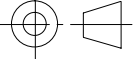
3rd angle projection 

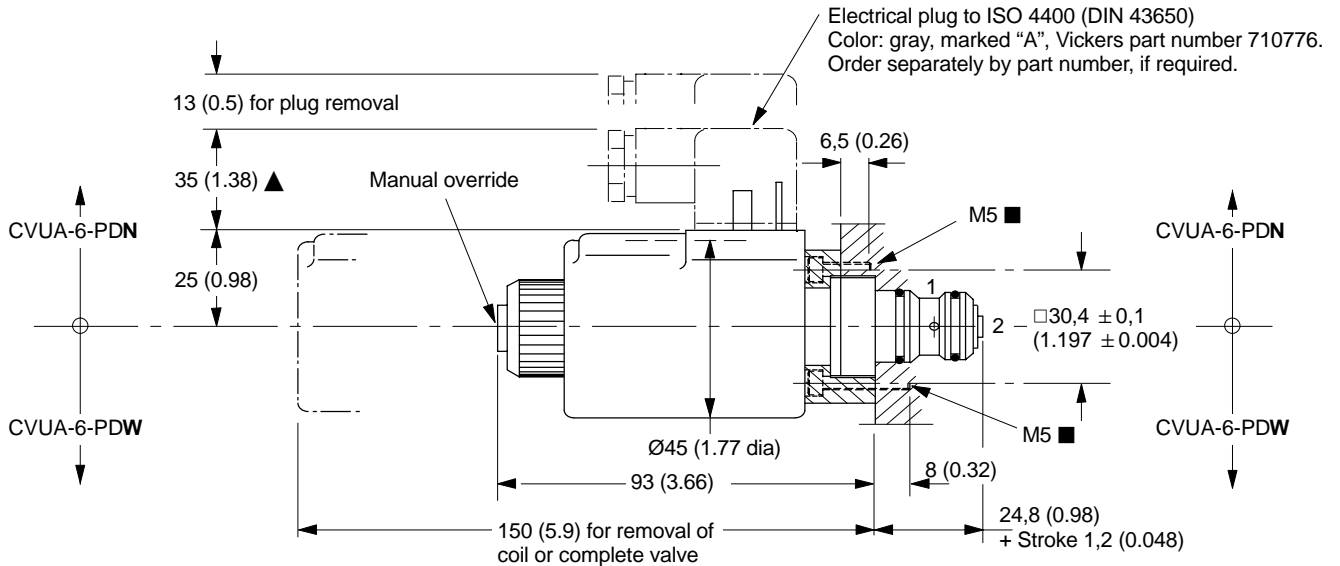

▲ May vary depending on plug source. ■ Torque to 4-6 Nm (35-53 lbf.in)

Recess Dimensions

Notes (metric dimensions)

- ▲ Ø18 +0/-0,2 x 26 ± 0,1 deep:
Ream Ø18 H7 x 20 deep min. ◆
- Ø19 +0/-0,2 x 14 ± 0,1 deep:
Ream Ø19 H7 x 8 deep min. ◆

Notes (inch dimensions)

- ▲ Diameter 0.709 +0/-0.008 x 1.024 ± 0.004 deep:
Ream Ø18 mm H7 x 0.79 deep min. ◆
- Diameter 0.748 +0/-0.008 x 0.551 ± 0.004 deep:
Ream Ø19 mm H7 x 0.32 deep min. ◆

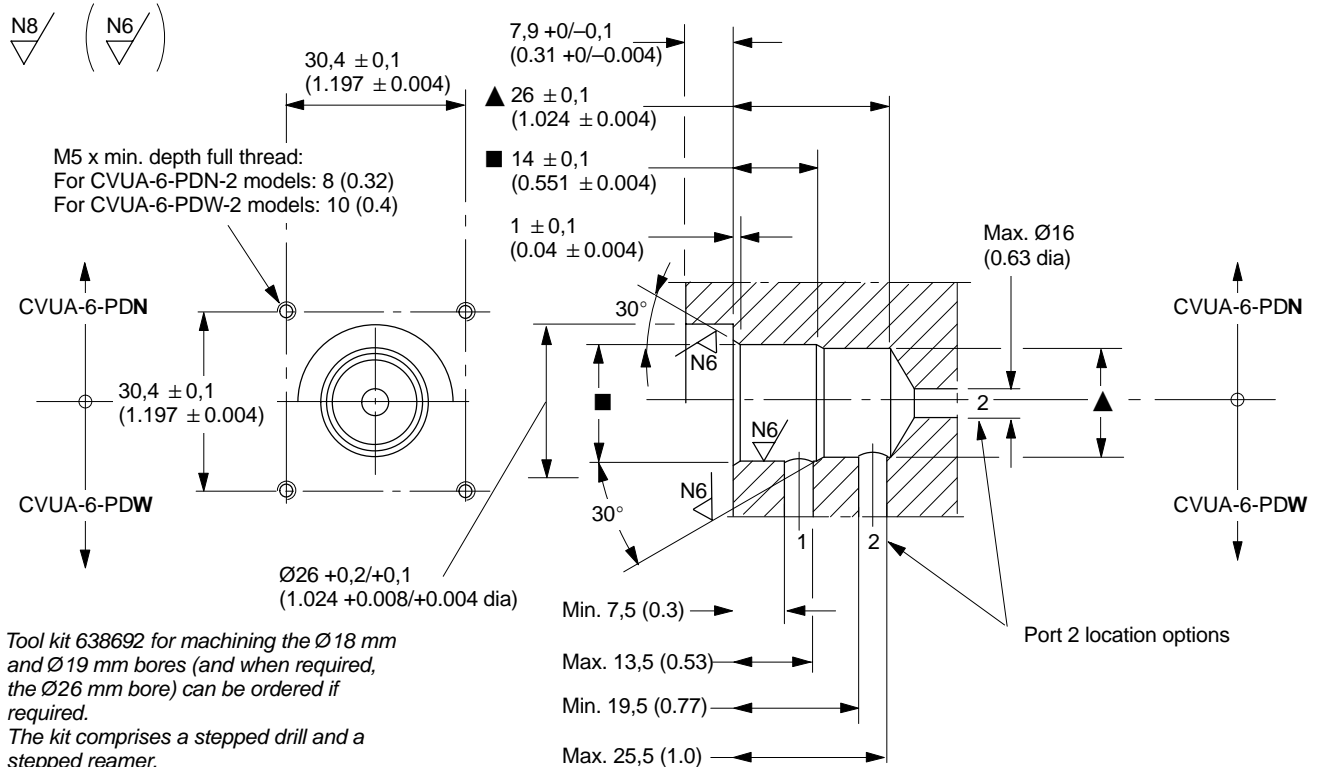

◆ Tool kit 638692 for machining the Ø18 mm and Ø19 mm bores (and when required, the Ø26 mm bore) can be ordered if required.
The kit comprises a stepped drill and a stepped reamer.

Model Types:
CVUA-6-PDN-3 and CVUA-6-PDW-3

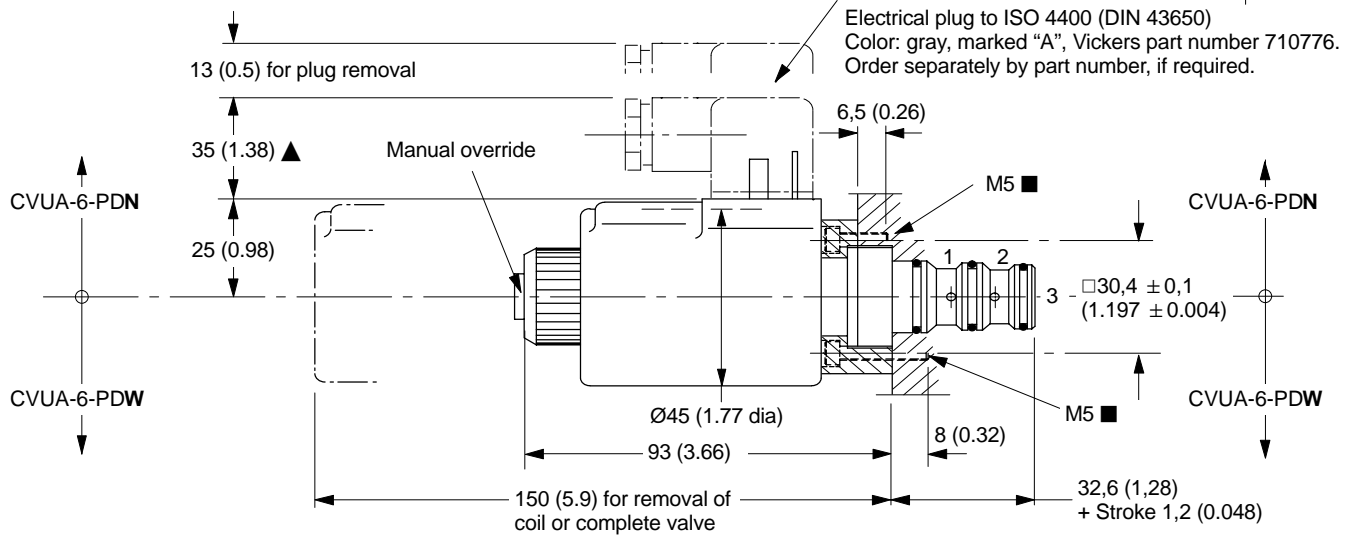
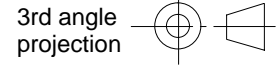

▲ May vary depending on plug source. ■ Torque to 4-6 Nm (35-53 lbf.in)

Recess Dimensions

Notes (metric dimensions)

- Ø17 +0/-0,2 x 34 ± 0,1 deep:
Ream Ø17 H7 x 32,5 deep min. ◆
- ▲ Ø18 +0/-0,2 x 26 ± 0,1 deep:
Ream Ø18 H7 x 20 deep min. ◆
- Ø19 +0/-0,2 x 14 ± 0,1 deep:
Ream Ø19 H7 x 8 deep min. ◆

Notes (inch dimensions)

- Diameter 0.669 +0/-0.008 x 1.339 ± 0.004 deep:
Ream Ø17 mm H7 x 1.28 deep min. ◆
- ▲ Diameter 0.709 +0/-0.008 x 1.024 ± 0.004 deep:
Ream Ø18 mm H7 x 0.79 deep min. ◆
- Diameter 0.748 +0/-0.008 x 0.551 ± 0.004 deep:
Ream Ø19 mm H7 x 0.32 deep min. ◆

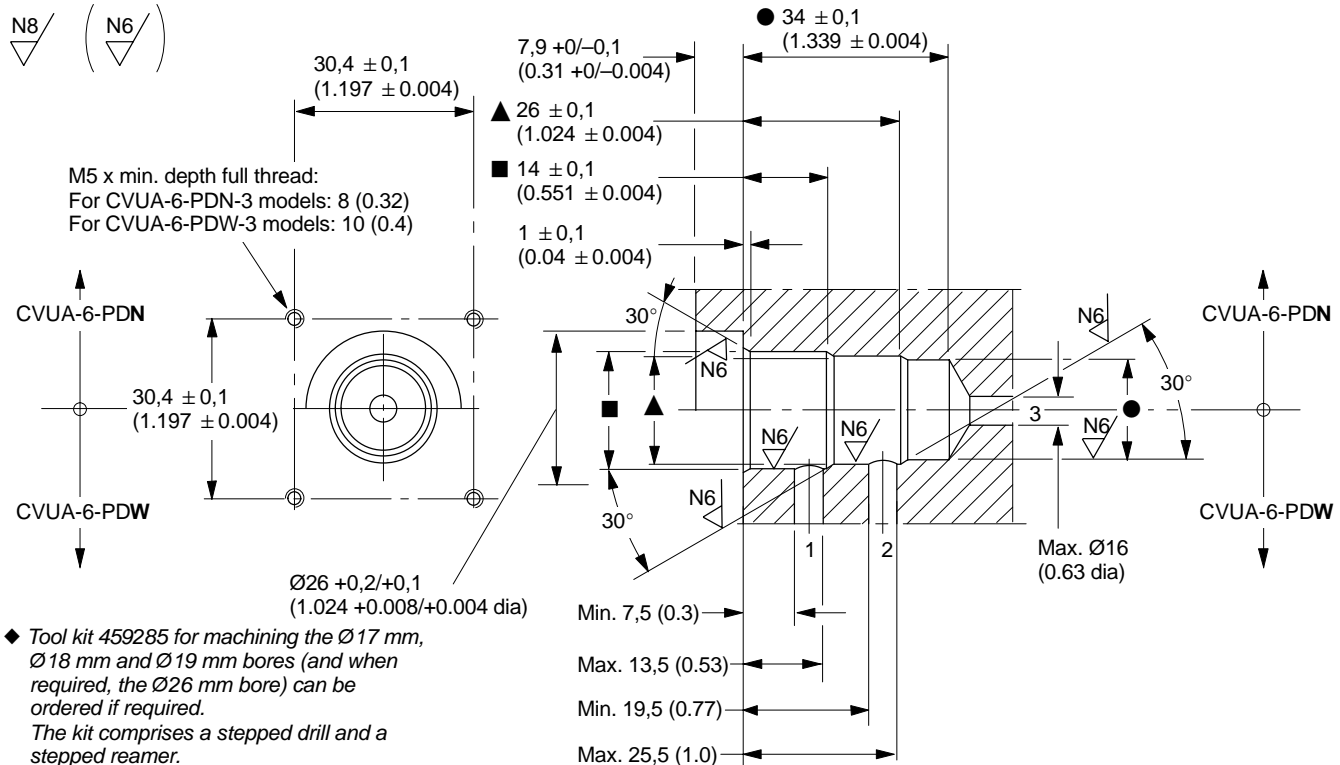
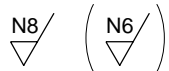

Model Types:
DG3VP-3-10*A and
DG4VP-3-10*C

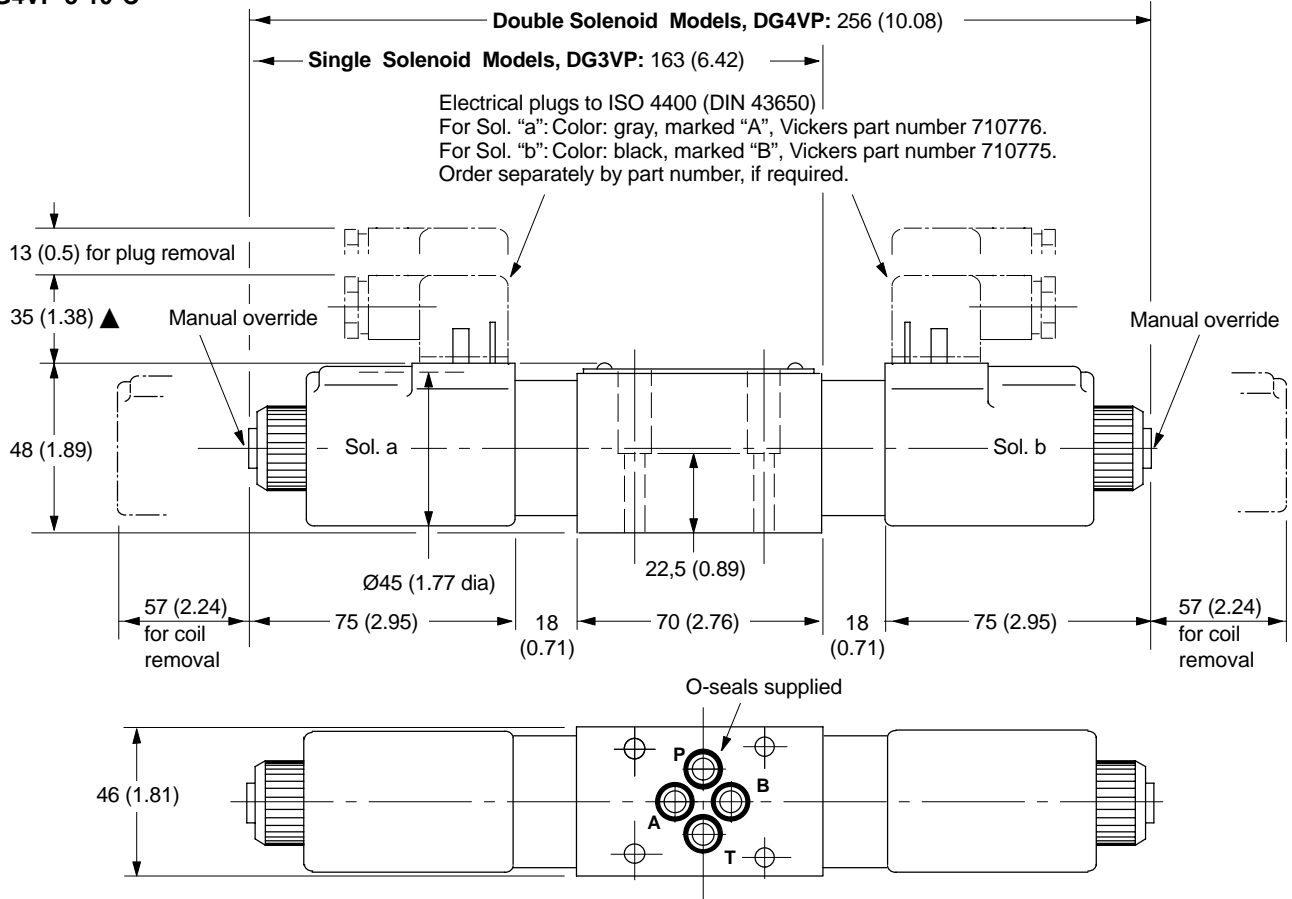

For details of mounting interface to ISO 4401, size 03, see catalog 2425.
 For details of Vickers mounting bolt kits, see catalog 2314.

Mass, Approx. kg (lb)

CVUA-6-PD*-2-M-U-*-10	0,85 (1.9)
CVUA-6-PD*-3-M-U-*-10	0,86 (1.9)
DG3VP-3-10*A-VM-U-*-10	1,75 (3.8)
DG4VP-3-10*C-VM-U-*-10	2,50 (5.5)

Spare Parts Information

The only replacement parts available for these valves are as follows:

Seal kit	Part number
F3-prefix valves	638532
Non-F3 valves	992686

Solenoid Coils

Coil	code	Coil rating	Part number
B	110V AC	50/115V AC 60	617947
D	220V AC	50/230V AC 60	617948
G	12V DC		617945
H	24V DC		617946

Electrical Plugs, ISO 4400 (DIN 43650)

Gray, marked "A"	710775
Black, marked "B"	710776

Tool Kits

For machining housing bores for:
 CVUA-6-PD*-2 valves Kit 638692
 CVUA-6-PD*-3 valves Kit 459285

Ordering Procedure

Order by full model designation or part number e.g.
 CVUA-6-PDN-2-M-U-B-10 valve
 710775 plug, gray marked "A"
 638692 tool kit.

Алматы (7273)495-231
Ангарск (3955)60-70-56
Архангельск (8182)63-90-72
Астрахань (8512)99-46-04
Барнаул (3852)73-04-60
Белгород (4722)40-23-64
Благовещенск (4162)22-76-07
Брянск (4832)59-03-52
Владивосток (423)249-28-31
Владикавказ (8672)28-90-48
Владимир (4922)49-43-18
Волгоград (844)278-03-48
Вологда (8172)26-41-59
Воронеж (473)204-51-73
Екатеринбург (343)384-55-89

Иваново (4932)77-34-06
Ижевск (3412)26-03-58
Иркутск (395)279-98-46
Казань (843)206-01-48
Калининград (4012)72-03-81
Калуга (4842)92-23-67
Кемерово (3842)65-04-62
Киров (8332)68-02-04
Коломна (4966)23-41-49
Кострома (4942)77-07-48
Краснодар (861)203-40-90
Красноярск (391)204-63-61
Курск (4712)77-13-04
Курган (3522)50-90-47
Липецк (4742)52-20-81

Магнитогорск (3519)55-03-13
Москва (495)268-04-70
Мурманск (8152)59-64-93
Набережные Челны (8552)20-53-41
Нижний Новгород (831)429-08-12
Новокузнецк (3843)20-46-81
Новый Сибирск (3496)41-32-12
Новосибирск (383)227-86-73
Омск (3812)21-46-40
Орел (4862)44-53-42
Оренбург (3532)37-68-04
Пенза (8412)22-31-16
Петрозаводск (8142)55-98-37
Псков (8112)59-10-37
Пермь (342)205-81-47

Ростов-на-Дону (863)308-18-15
Рязань (4912)46-61-64
Самара (846)206-03-16
Санкт-Петербург (812)309-46-40
Саратов (845)249-38-78
Севастополь (8692)22-31-93
Саранск (8342)22-96-24
Симферополь (3652)67-13-56
Смоленск (4812)29-41-54
Сочи (862)225-72-31
Ставрополь (8652)20-65-13
Сургут (3462)77-98-35
Сыктывкар (8212)25-95-17
Тамбов (4752)50-40-97
Тверь (4822)63-31-35

Тольятти (8482)63-91-07
Томск (3822)98-41-53
Тула (4872)33-79-87
Тюмень (3452)66-21-18
Ульяновск (8422)24-23-59
Улан-Удэ (3012)59-97-51
Уфа (347)229-48-12
Хабаровск (4212)92-98-04
Чебоксары (8352)28-53-07
Челябинск (351)202-03-61
Чита (3022)38-34-83
Якутск (4112)23-90-97
Ярославль (4852)69-52-93

Россия +7(495)268-04-70

Казахстан +7(7172)727-132

Киргизия +996(312)96-26-47

<https://vickers.nt-rt.ru> || vsh@nt-rt.ru