

Алматы (7273)495-231
Ангарск (3955)60-70-56
Архангельск (8182)63-90-72
Астрахань (8512)99-46-04
Барнаул (3852)73-04-60
Белгород (4722)40-23-64
Благовещенск (4162)22-76-07
Брянск (4832)59-03-52
Владивосток (423)249-28-31
Владикавказ (8672)28-90-48
Владимир (4922)49-43-18
Волгоград (844)278-03-48
Вологда (8172)26-41-59
Воронеж (473)204-51-73
Екатеринбург (343)384-55-89

Иваново (4932)77-34-06
Ижевск (3412)26-03-58
Иркутск (395)279-98-46
Казань (843)206-01-48
Калининград (4012)72-03-81
Калуга (4842)92-23-67
Кемерово (3842)65-04-62
Киров (8332)68-02-04
Коломна (4966)23-41-49
Кострома (4942)77-07-48
Краснодар (861)203-40-90
Красноярск (391)204-63-61
Курск (4712)77-13-04
Курган (3522)50-90-47
Липецк (4742)52-20-81

Магнитогорск (3519)55-03-13
Москва (495)268-04-70
Мурманск (8152)59-64-93
Набережные Челны (8552)20-53-41
Нижний Новгород (831)429-08-12
Новокузнецк (3843)20-46-81
Ноябрьск (3496)41-32-12
Новосибирск (383)227-86-73
Омск (3812)21-46-40
Орел (4862)44-53-42
Оренбург (3532)37-68-04
Пенза (8412)22-31-16
Петрозаводск (8142)55-98-37
Псков (8112)59-10-37
Пермь (342)205-81-47

Ростов-на-Дону (863)308-18-15
Рязань (4912)46-61-64
Самара (846)206-03-16
Санкт-Петербург (812)309-46-40
Саратов (845)249-38-78
Севастополь (8692)22-31-93
Саранск (8342)22-96-24
Симферополь (3652)67-13-56
Смоленск (4812)29-41-54
Сочи (862)225-72-31
Ставрополь (8652)20-65-13
Сургут (3462)77-98-35
Сыктывкар (8212)25-95-17
Тамбов (4752)50-40-97
Тверь (4822)63-31-35

Тольятти (8482)63-91-07
Томск (3822)98-41-53
Тула (4872)33-79-87
Тюмень (3452)66-21-18
Ульяновск (8422)24-23-59
Улан-Удэ (3012)59-97-51
Уфа (347)229-48-12
Хабаровск (4212)92-98-04
Чебоксары (8352)28-53-07
Челябинск (351)202-03-61
Череповец (8202)49-02-64
Чита (3022)38-34-83
Якутск (4112)23-90-97
Ярославль (4852)69-52-93

Россия +7(495)268-04-70

Казахстан +7(7172)727-132

Киргизия +996(312)96-26-47

<https://vickers.nt-rt.ru> || vsh@nt-rt.ru

Pilot Operated Directional Control Valves

DG5S4-04-60/70
NFPA D07, ISO-4401-07

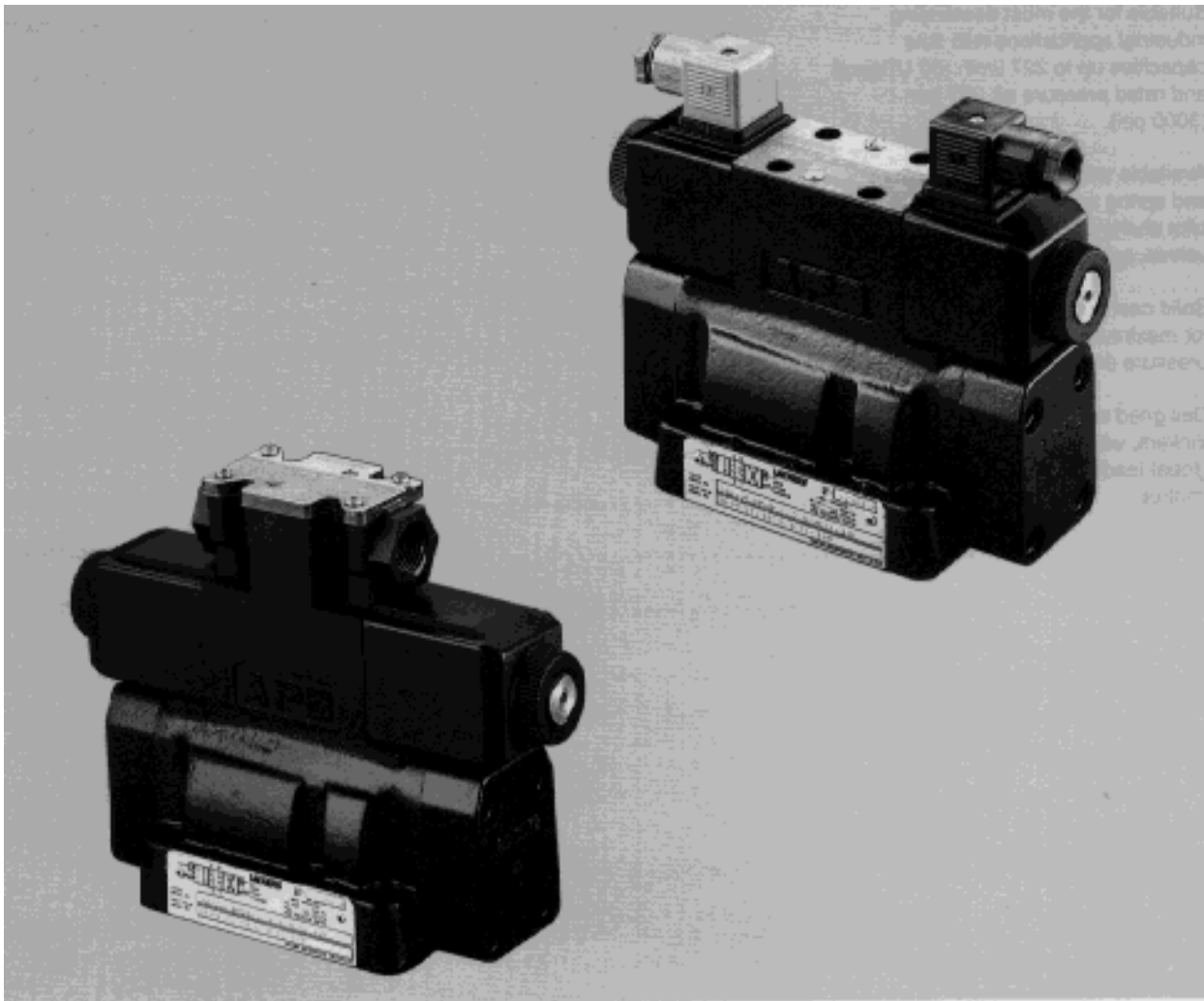

Table of Contents

| | |
|----------------------------------|----|
| DG5S4-04 Model Code | 4 |
| General Information | 6 |
| Basic Characteristics | |
| Shifting Action | |
| Mounting Position | |
| Application | |
| Installation Data | |
| Optional Features | 7 |
| Functional Symbols | |
| Service Information | |
| Models & Graphical Symbols | 8 |
| Pressure Drop | 9 |
| Flow Ratings | 10 |
| Installation Dimension | 11 |
| Subplates & Bolt Kits | 13 |
| Electrical Information | 14 |
| Application Data | 18 |

Introduction

DG5S4-04 models are two-stage directional valves having an integrally mounted DG4V-3(S)-60 pilot valve.

These valves are generally used to control the direction of flow in a hydraulic circuit. This in turn would control the movement of a work cylinder or the rotation of a fluid motor.

Features and Benefits

- Suitable for the most demanding industrial applications with flow capacities up to 227 l/min (60 USgpm) and rated pressure of 210 bar (3000 psi).
- Available with a wide variety of spool and spring arrangements, stroke and pilot choke adjustments, integral check valves, and port orifices.
- Solid cast body with cored passages for maximum strength and minimal pressure drop.
- Designed and manufactured by Vickers, with over 70 years as the global leader in fluid power and motion control.

Model Code

Pilot Operated Directional Valves

(F3)-DG5S4 - 04 - * * (L) - ** (X) - * - E - T - * - (V) M - S* - * ** * (L) - ** * - *** - 60/70**

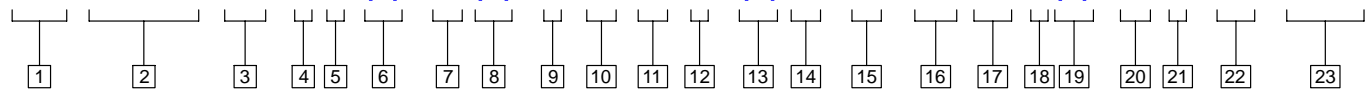

1 Special seals

F3 - For mineral oil and fire resistant fluids
Blank - Omit if not required

2 Directional control valve

Manifold or subplate mounting, solenoid controlled, pilot operated, sliding spool, rated pressure 210 bar (3000 psi)

3 Interface

04 - NFPA-D07 (ISO-4401-07)

4 Spool types

0, 2, 3, 4, 6, 8, 9, 31, 33
See models & graphic symbols table for description.

5 Spool/Spring arrangement

A - Spring offset
B - Spring centered with solenoid "A" removed
C - Spring centered
F - Shift to center from offset (single solenoid)
N - No-spring detented (pilot only)

6 Left-Hand assembly

L - Single solenoid models only. Omit for right-hand assembly. (For right-hand assembly P to A when solenoid 'a' is energized.)

7 Manual override options

Blank - Plain override solenoid end only
H - Waterproof override solenoid ends only
H2 - Waterproof override both ends of single solenoid
P2 - Plain override both ends of single solenoid.
Y - Lockable manual overrides solenoid ends only/DC only
Z - No overrides in either end

8 Response type

X - Fast response
Blank - Standard low shock models

9 Spool control modifications

1 - Stroke adjustments, both ends
2 - Pilot choke (dual) adjustments
3 - Pilot choke and stroke adjustments
7 - Stroke adjustment "A" port end only
8 - Stroke adjustment "B" port end only
2-7 - Dual pilot choke & stroke adjustment "A" port end only
2-8 - Dual pilot choke & stroke adjustment "B" port end only
Blank - Omit if not required

10 Pilot pressure

E - External pilot pressure
Blank - Internal pilot pressure

11 Pilot drain

T - Internal pilot drain
Blank - External pilot drain

12 Pressure port check valve

K - 0,35 bar (5 psi) cracking pressure
R - 3,4 bar (50 psi) cracking pressure
S - 5,2 bar (75 psi) cracking pressure
Blank - Omit if not required

13 Solenoid energization identity

V - Solenoid identification determined by position of solenoid (solenoid "A" at port "A" end and/or solenoid "B" at port "B" end)
Blank - Standard arrangement for ANSI B93.9 (energize solenoid "A" for flow P to A port)
(Code V for any valve with code 4 or code 8 spool)

14 Flag symbol

M - Electrical options and features

15 Spool indicator switch

(Available on models with high performance pilot DG4V3 only)
S3 - Normally open (available on valves with code P* only)
S4 - Normally closed (available on valves with code P* only)
S5 - Free leads (available on valves with coil type code F only)
S6 - LVDT type DC switch with Pg7 connector plug

16 Coil type

U - ISO 4400
F - Flying lead
SP1 - Single 6,3 mm spade to IEC 760
SP2 - Dual 6,3 mm spade to IEC 760

17 Electrical connections

(Code F coil only)
T - Wired terminal block
PA - Insta-plug male receptacle only
PB - Insta-plug male & female receptacle
PA3 - NFPA 3-pin connector
PA5 - NFPA 5-pin connector
Blank - Omit if not required

18 Housing

(Code F coil only)
W - 1/2 NPT thread wiring housing
J - 20 mm thread wiring housing
Blank - Omit if not required

19 Solenoid indicator lights

(Code F coil w/Code T electrical connections only)
L - Indicator lights
Blank - Omit if not required

Model Code cont'd

20 Coil identification

- A - 110V/50 Hz
- B - 110V/50 Hz, 120V/60 Hz
- C - 220V/50 Hz
- D - 230V/50 Hz, 240V/60 Hz
- G - 12V DC
- H - 24V DC
- DJ - 98V DC
- P - 110V DC

21 Pilot valve tank pressure rating

- 2 - 10 bar (145 psi) DG4V3-60 with S3, S4, or S5 spool indicator switch
- 4 - 70 bar (1000 psi) hazardous model
- 5 - 100 bar (1450 psi) DG4V3S-60
- 6 - 160 bar (2285 psi) DG4V3-60 with AC solenoids and optional S6 spool indicator switch
- 6 - 210 bar (3000 psi) DG4V3-60 with DC solenoids and optional S6 spool indicator switch

22 Pilot valve port orifices

- | Code | Orifice Diameter |
|------|--------------------|
| *00 | Solid plug |
| *03 | 0,30 mm (0.012 in) |
| *06 | 0,60 mm (0.024 in) |
| *08 | 0,80 mm (0.030 in) |
| *10 | 1,00 mm (0.040 in) |
| *13 | 1,30 mm (0.050 in) |
| *15 | 1,50 mm (0.060 in) |
| *20 | 2,00 mm (0.080 in) |
| *23 | 2,30 mm (0.090 in) |
- Blank - Omit if not required
(* = P, T, A, and/or B as required)

23 Design number

Subject to change. Installation dimensions remain as shown for designs 60 through 69 and 70 through 79.

- 60 - DG4V3S-60 pilot valve
- 70 - DG4V3-60 pilot valve

Refer to GBC-2010 for more information on the pilot control valve.

General Information

Basic Characteristics

Max. pressure: 210 bar (3000 psi)
Max. flow: 227 l/min (60 USgpm)
Max. pressure port T (external drain):
. 210 bar (3000 psi)
Max. pressure port T (internal drain):
DG4V-3S 100 bar (1450 psi)
DG4V-3 210 bar (3000 psi)
Max. pilot pressure:
. 210 bar (3000 psi)
Weights - See installation drawings.

Mounting Interface

ISO-4401-07
NFPA D07

Shifting Action

Spring centered, pressure centered and spring offset models must be energized continuously to maintain the shifted position. Detented no-spring models may be energized momentarily (approximately 0.1 second).

Pressure centered and spring centered models return valve spool to center position when solenoids are de-energized.

Spring offset models return spool to offset position by pilot pressure when solenoid is de-energized.

When no-spring detented models are de-energized, the pilot and main spools remain in the last position attained, provided there is no shock, vibration, unusual pressure transients and the spool axis is horizontal. If pilot pressure fails or falls below the minimum, the main spool will spring center (at spring centered flow rates) and cannot drift to reverse flow (pilot stage remains in detented position).

CAUTION

Surges of oil in a common tank line serving these and other valves can be of sufficient magnitude to cause inadvertent shifting of these valves. This is particularly critical in the no-spring detented type valves. Separate tank lines or a vented manifold with a continuous downward path to tank is necessary. (This also applies to connection X on spring offset valves, if X is piped as a drain.)

NOTE

Any sliding spool valve, if held for long periods of time, may stick and not spring return due to fluid residue formation and therefore, should be cycled periodically to prevent this from happening.

When used as other than a normal 4-way valve, consult your Vickers representative.

Mounting Position

No-spring detented valves must be installed with the longitudinal axis horizontal for good machine reliability. The mounting position of spring offset models is unrestricted provided that the pilot pressure supply is maintained as required. (Spring offset valves do not have a spring in the main spool section.)

Application

All spools at zero flow require 5,2 bar (75 psi) minimum pilot pressure. At maximum flow without malfunction 5,5 bar (80 psi) is required for open center spools (types 0, 4, 8 & 9) and 8,6 bar (125 psi) is required for closed center spools (types 2, 3, 6, 31 & 33).

NOTE

The pilot pressure stated is based on internally piloted and externally drained models in which the pilot pressure is equal to the pressure at the valve pressure port. With models having pressure open or partially open to tank at center position, pilot pressure can be assured by imposing a back pressure of at least the required minimum pilot pressure at the tank outlet connection (this back pressure will be present at cylinder ports if spool is "0" or "9" type). When pilot pressure from separate source (external) is required, an external connection can be provided. Order according to model code.

Installation Data

Pilot Valve Drain

Internal: To provide maximum flow without malfunction, pilot pressure of internally drained valves must always exceed tank line back pressure by a minimum of 5,2 bar (75 psi) for spool types 0, 4, 8 & 9 and a minimum of 10,3 bar (150 psi) for all other spools.

Internal drain may be used with all valves, however, an integral pressure port check valve (ref. integral check valve on page 5) is required for valves using an internal pilot source with an open center spool (0, 4, 8 and 9 types) in order to maintain pilot pressure. If an external pilot source is used, an integral check is not required. When internal pilot drain is required, order according to model code. (Pressure centered valves not included.)

External: When the possibility of pressure surges in the tank line exists, externally drained valves are recommended. For externally drained models, the pilot valve drain line must be piped directly to tank through a surge free line so there will be no back pressure at this drain. (Reference connection "Y".)

Optional Features/Functional Symbols

Pressure Centered Drain

(external only)

The external pilot drain explanation on the previous page applies to “Y” drain port. Pressure centered “W” drain connection must be piped directly to tank through a surge free line so there will be no back pressure at this drain.

Optional Features

Integral Check Valve

For open center spools - When using internal pilot pressure and internal pilot drain, select appropriate check spring model (K, R or S) from “Pressure Drop Across Check Valve” curve on page 8. Total pressure drop required is 5,2 bar (75 psi), (see pilot pressure ratings and note) therefore, determine valve ΔP (P to T) at the actual application flow rate. Subtract this value from 5,2 bar (75 psi) and call its value “C”. Refer to the check valve pressure drop curve at the application flow rate and select the spring model letter whose curve is above this pressure (bar/psi) value “C”.

Fast Response

Use of this option decreases shift time approximately 60%. However, system shock generation is correspondingly increased. The fast response option is not recommended for pilot pressure exceeding 138 bar (2000 psi).

Service Information

Refer to specific Vickers parts drawing for service parts information. A complete parts breakdown is contained in this drawing.

Order by literature number.

DG5S4-04-60/70 I-3891-S

Typical shift times in milliseconds for spring centered valves at rated flow and pressure. (See note on fast response option.)

| Port Condition | P to A or B | | | | A or B to P |
|----------------------|-------------|---------|--------|----------|---------------|
| | 80 ms | 125 ms | 500 ms | >1000 ms | |
| Pilot Pressure | 80 ms | 125 ms | 500 ms | >1000 ms | Spring return |
| Open Center Spools | 180 ms* | 130 ms | 65 ms | 50 ms | 50 ms |
| Closed Center Spools | N/A | 125 ms* | 65 ms | 50 ms | 50 ms |

* Minimum pilot pressure

Functional Symbols

Double Solenoid -
Spring centered “C”

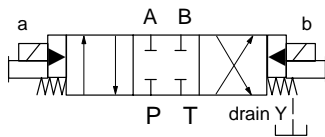

Double Solenoid -
No-spring, detented “N”

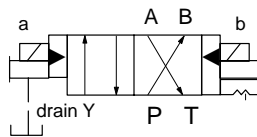

Single Solenoid -
Spring centered “B”

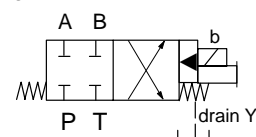

Single Solenoid -
Shift to center “F”

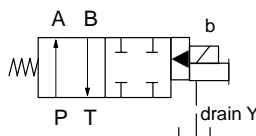

Single Solenoid -
Spring offset “A”

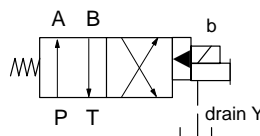

Models & Graphical Symbols

| Shift to Center -F*- | Spring Centered -C*- | Spring Offset -A- | Pressure Centered -B- | No-Spring Detented -N- | | |
|-------------------------|-------------------------|----------------------|--------------------------|---------------------------|---|--------------------------------------|
| All Spools | All Spools | 0, 2, 6, 9 & 33 | All Spools | 0, 2, 6, 9 & 33 | | |
| | | | | | Center Position & Spool Type | Description Center Position |
| DG5S4-040F | DG5S4-040C | DG5S4-040A | DG5S4-040B | DG5S4-040N | | |
| DG5S4-042F | DG5S4-042C | DG5S4-042A | DG5S4-042B | DG5S4-042N | "0" | Opens to T all ports |
| DG5S4-042F | DG5S4-042C | DG5S4-042A | DG5S4-042B | DG5S4-042N | "2" | Closed to T all ports |
| DG5S4-043F | DG5S4-043C | | DG5S4-043B | | "3" | Closed P & B open A to T |
| DG5S4-044F | DG5S4-044C | | DG5S4-044B | | "4" | Tandem P to T closed crossover |
| DG5S4-046F | DG5S4-046C | DG5S4-046A | DG5S4-046B | DG5S4-046N | "6" | Closed P only open A & B to T |
| DG5S4-048F | DG5S4-048C | | DG5S4-048B | | "8" | Tandem P to T open crossover |
| DG5S4-049F | DG5S4-049C 40-S327 ▲ | DG5S4-049A | DG5S4-049B | DG5S4-049N 50-S327 ▲ | "9" | Open to T all ports over tapers |
| DG5S4-0431F | DG5S4-0431C | | DG5S4-0431B | | "31" | Closed P & A open B to T |
| DG5S4-0433F | DG5S4-0433C | DG5S4-0433A | DG5S4-0433B | DG5S4-0433N | "33" | Closed P open A & B to T over tapers |

* 4 & 8 type spools - offset position flow paths reversed.









■ 4 & 8 type spools - flow paths reversed.

▲ Maximum flow limited to 170 l/min (45 USgpm) @ 69 bar (1000 psi), 76 l/min (20 USgpm) or 45 l/min (12 USgpm) @ 210 bar (3000 psi).

→ Full flow

↔ Restricted flow

Pressure Drop

| Spool Type & Center Position | Description | Pressure Drop bar (psi) @95 l/min (25 USgpm) | | | | |
|---|------------------------------------|--|--------------|--------------|--------------|-----------------|
| | | P → A | B → T | P → B | A → T | P → T on Center |
| "0"  | Open center all ports | 1,72 (25) | 2,76 (40) | 1,72 (25) | 1,72 (25) | 2,76 (40) |
| "2"  | Closed center all ports | 2,41 (35) | 3,10 (45) | 2,41 (35) | 2,41 (35) | – |
| "3"  | Closed P & B A open to T | 2,41 (35) | 3,10 (45) | 2,41 (35) | 1,72 (25) | – |
| "4"  | Tandem - closed crossover | 4,83 (70) | 5,86 (85) | 4,83 (70) | 5,86 (85) | 5,17 (75) |
| "6"  | Closed center P only | 2,41 (35) | 3,10 (40) | 2,41 (35) | 1,72 (25) | – |
| "8"  | Tandem - open crossover | 2,41 (35) | 4,14 (60) | 2,41 (35) | 3,45 (50) | 4,14 (60) |
| "9"  | Open center partial - all ports | 1,72 (25) | 3,10 (40) | 1,72 (25) | 1,72 (25) | – |
| "33"  | Closed center bleed A & B | 2,41 (35) | 3,10 (45) | 2,41 (35) | 2,41 (35) | – |

Note

When solenoid "a" is energized, flow is always P to A. When solenoid "b" is energized, flow is always P to B. This is in accordance with the ANSI-B93.9 standard. Standard spring offset valves are assembled right hand, such that flow is P to A in the spring offset position (solenoid is de-energized). Solenoid "a" and "b" are identified on the diagram plate.

- Figures in the pressure drop table give approximate pressure drop (ΔP) when passing 95 l/min (25 USgpm) flow (Q) of 21 cSt (100 SUS) fluid(s) having .865 specific gravity.
- For any other flow rate (Q_1), the pressure drop (ΔP_1) will be approximately: $\Delta P_1 = \Delta P(Q_1/Q)^2$
- For any other viscosity(s), the pressure drop (ΔP), will change as follows:
- For any other specific gravity (G_1)*, the pressure drop (ΔP_1) will be approximately: $\Delta P_1 = \Delta P(G_1/G)$

* Specific gravity of fluid may be obtained from its producer. The value is higher for fire-resistant fluids than for oil.

| Viscosity | | | | | | | | |
|------------------------------|------|-------|-------|-------|-------|-------|-------|--|
| cSt | 14 | 32 | 43 | 54 | 65 | 76 | 86 | |
| (SUS) | (75) | (150) | (200) | (250) | (300) | (350) | (400) | |
| % of ΔP (Approx.) | 93 | 111 | 119 | 126 | 132 | 137 | 141 | |

Flow Ratings

Pressure Drop Across Check Valve

Total pressure drop is determined from the pressure drop induced by check valve and other sources. (See graph, pilot pressure and integral valve notes.) Total must be greater than minimum bar/psi for good machine reliability.

To determine check valve cracking pressure needed to provide pilot pressure, calculate total pressure drop through valve (P to T) on center at minimum flow. Total pressure drop is determined from pressure drop chart for standard valve and adding pressure drop induced by check valve (see graph). Total must be greater than the minimum for good machine reliability. (See pilot pressure and integral check valve notes.)

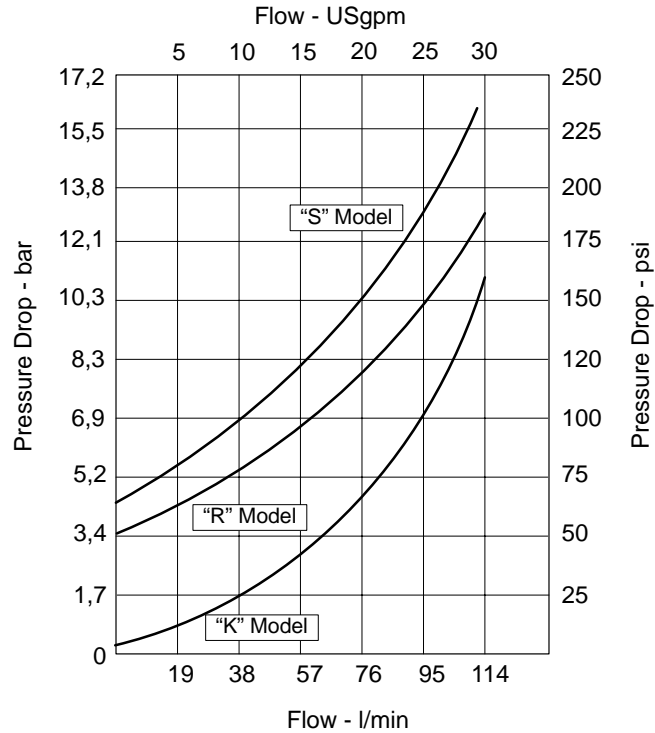

Flow Ratings

| Valve Type | Spool Type | Pressure bar (psi) | Recommended Flow Capacity l/min (USgpm) | Maximum Flow without Malfunction l/min (USgpm) |
|-----------------------------------|-----------------|--------------------|---|--|
| Spring Centered & Shift to Center | 2, 3, 6, 31, 33 | 207 (3000) | 95 (25) | 227 (60)* |
| | 0 | 207 (3000) | 95 (25) | 114 (30) |
| | 4, 8† | 207 (3000) | 45 (12) | 45 (12) |
| | | 138 (2000) | 76 (20) | 76 (20) |
| | | 69 (1000) | 95 (25) | 114 (30) |
| Spring Offset | 0, 2 | 207 (3000) | 95 (25) | 227 (60)* |
| | 6 | 207 (3000) | 95 (25) | 227 (60)* |
| | 9 | 207 (3000) | 95 (25) | 227 (60)* |
| No-Spring | 0, 2, 6, 9 ■ | 207 (3000) | 95 (25) | 227 (60)* ■ |

* As system flow increases the minimum pilot pressure required increases. These spools will operate satisfactorily in excess of 227 l/min (60 USgpm) with higher pilot pressures.

■ Maximum flow limited to 170 l/min (45 USgpm) @ 69 bar (1000 psi), 76 l/min (20 USgpm) or 45 l/min (12 USgpm) @ 210 bar (3000 psi).

† Fast valve switching of large oil volumes, without adequate decompression circuitry, can develop instantaneous flows well above the maximum ratings. The type 8 spool may spin within the body, causing unusual valve body bore wear when applied in this type of circuit. With this and other spool types, valve malfunction might occur.

Installation Dimensions

Double Solenoid, Spring Centered & No-Spring Detented Types

Millimeter (inches)

Weight @ 6,8 kg (15 lbs)

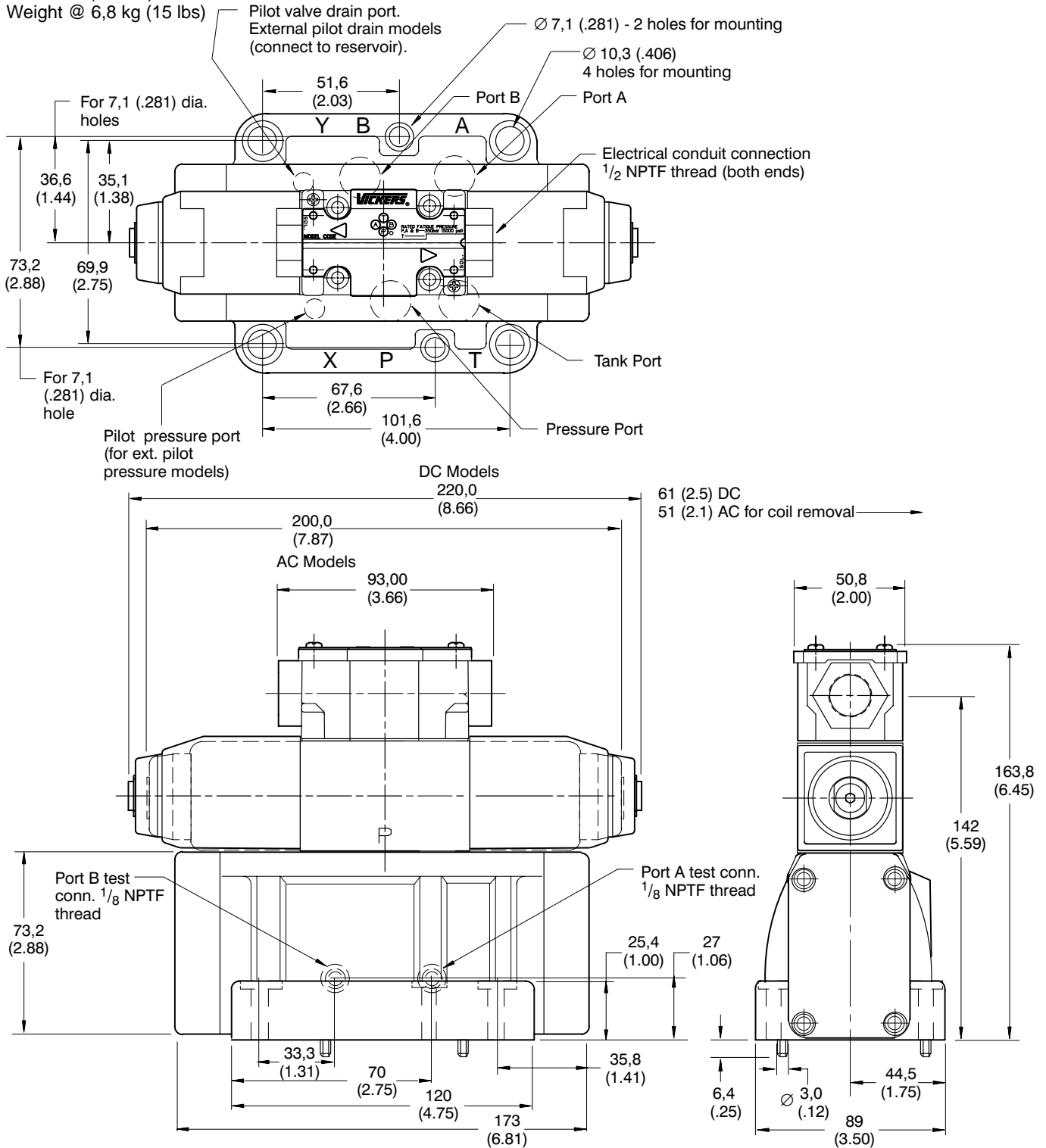

Installation Dimensions

Single Solenoid - Spring Offset, Spring Centered & Shift-to-Center

Millimeter (inches)
Weight @ 6,4 kg (14 lbs)

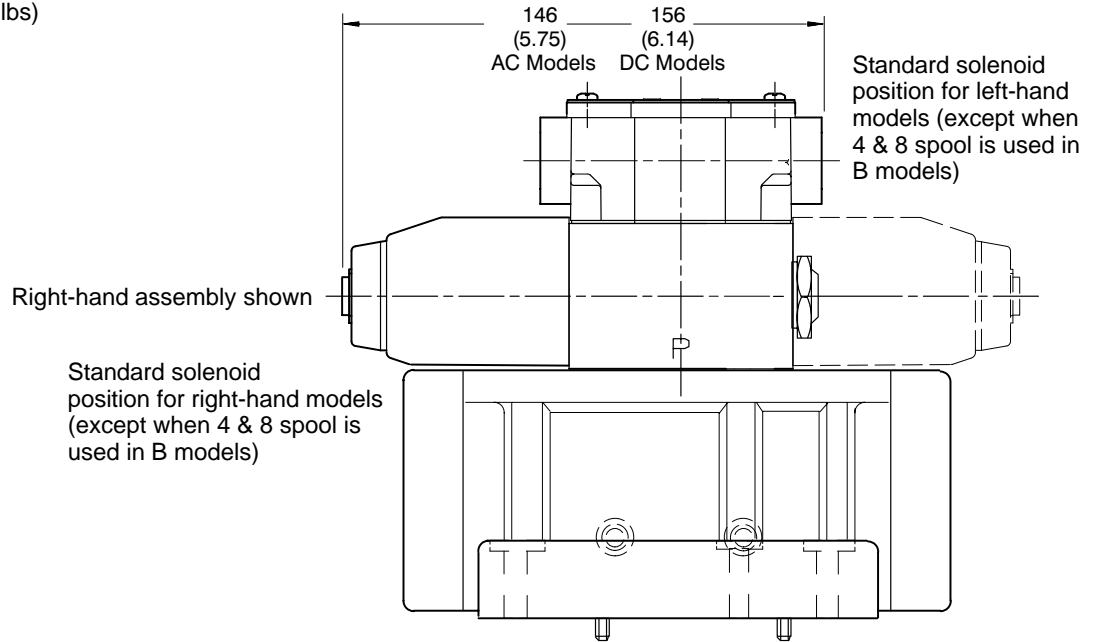

Pilot Choke and Stroke Adjustments

Pilot Choke Adjustment(s)

Pilot choke is adjusted by backing off locknuts and turning adjusting screws inward (clockwise) to decrease rate of spool travel and outward (counterclockwise) to increase the rate. Pilot oil for models with this feature should be taken from a source having a constant pressure. See spool control modifications in model code.

Stroke Adjustment(s)

Stroke adjustment limits movement of the main stage spool. Backing off the jam nut and turning the adjusting screw inward (clockwise) decreases spool stroke. See spool control modifications in model code.

Weights: Dual pilot - 8,6 kg (19 lbs)
1 Stroke adj. - 6,9 kg (15.3 lbs)
2 Stroke adj. - 7 kg (15.5 lbs)
Pilot choke & Stroke adj. - 8,8 kg (19.5 lbs)

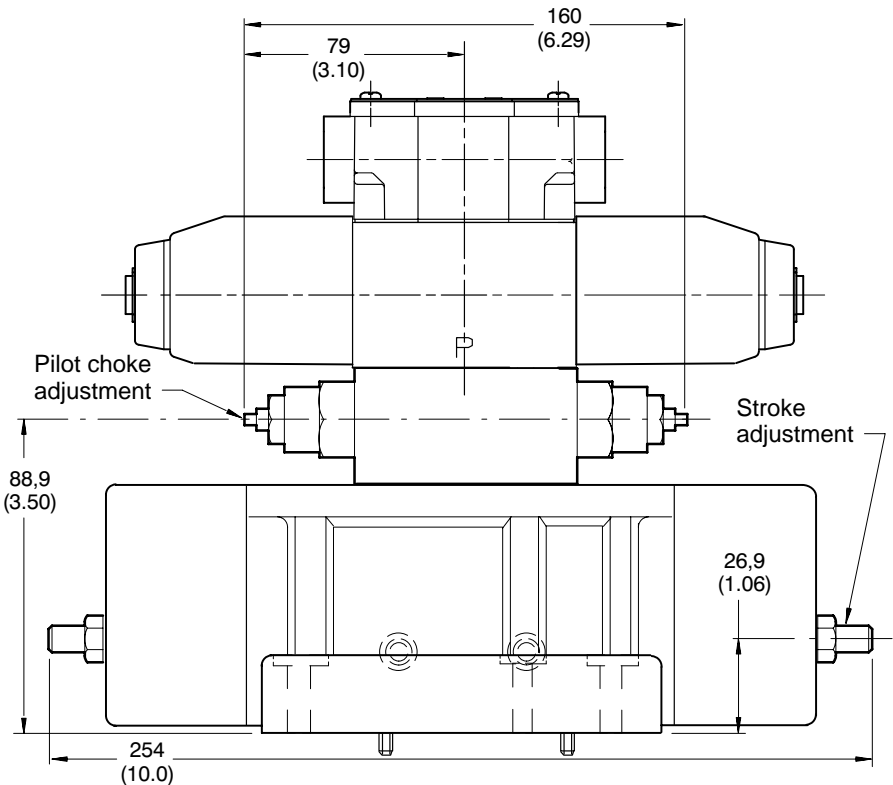

Subplates & Bolt Kits

Valves, subplates and mounting bolts must be ordered separately.

Example:

One (1) DG5S4-040A-M-W-* Valve
 One (1) DGSM-04-12S-20 Subplate
 One (1) BKDG-04-650 Bolt Kit †

† Maximum recommended bolt torque
 1/4" screws - length 1.50" - 12,7 Nm (112 in. lbs.)
 3/8" screws - length 1.75" - 35,6 Nm (315 in. lbs.)

Weight: @ 3,2 kg (7 lbs)

When subplate is not used, a machined pad (as indicated by subplate shaded area, below) must be provided for mounting. Pad must be flat within 0,0127 mm (.0005 inch) and smooth within 1,6 µm (63 microinch). Mounting bolts, when provided by customer, should be SAE grade 7 or better.

Mounting Subplates

Millimeters (inches)

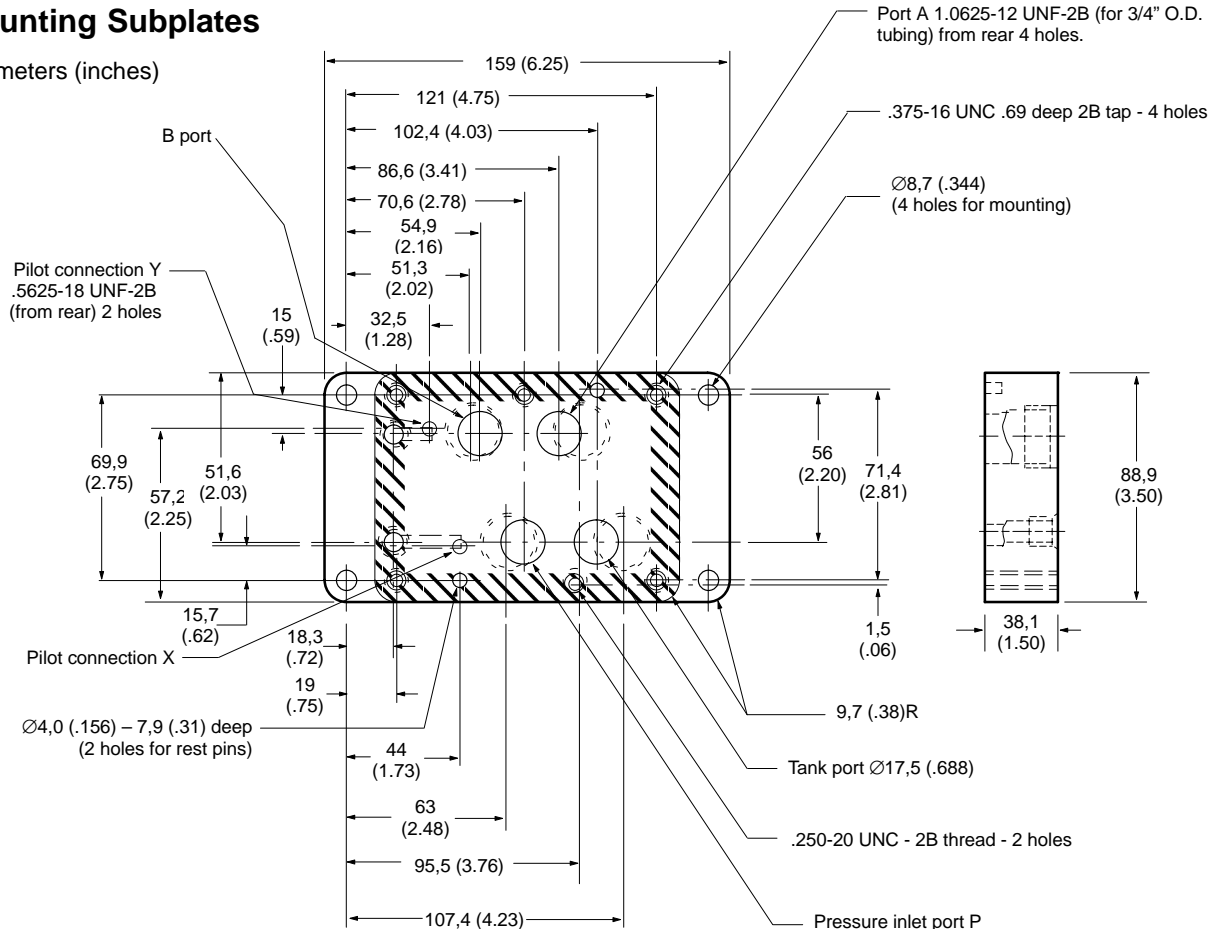

Pilot Valve Port Restrictor Plugs

Restrictor plugs are available for use in ports P, T, A, or B. These can be used for restricting flow or for circuit dampening. Restrictor plugs are not recommended for use above 210 bar (3000 psi) system pressure.

| | | |
|--------|--------------|-----|
| 694345 | 1,30 (0.050) | *13 |
| 694346 | 1,50 (0.060) | *15 |
| 694347 | 2,00 (0.080) | *20 |
| 694348 | 2,30 (0.090) | *23 |

† - Available in multiples of 25 per part number

* - P, T, A, or B as required

| Part Number† | Orifice Ø | Model Code |
|--------------|--------------|------------|
| 694353 | Blank | *00 |
| 694341 | 0,30 (0.012) | *03 |
| 694342 | 0,60 (0.024) | *06 |
| 694343 | 0,80 (0.030) | *08 |
| 694344 | 1,00 (0.040) | *10 |

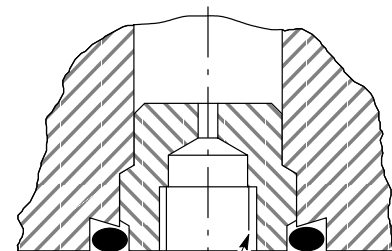

M5 x 0.8-6H thread for plug extraction

Electrical Information

Solenoids

On all models when solenoid A is energized, flow is always P to A. When solenoid B is energized, flow is always P to B. This is in accordance with the ANSI-B93.9 standard. Solenoid A and B are identified on the main plate on the top of the valves terminal box. Single solenoid models can be assembled left-hand (flow is P to B when solenoid A is energized).

Solenoid Energizing

Spring centered and spring offset types will be spring positioned unless solenoid is energized continuously. No-spring detented valves may be energized momentarily, approximately 0.1 second; when solenoid is de-energized spool will remain in last position attained provided there is no shock, vibration, or unusual pressure transients.

Electrical Connection

A 1/2" NPTF thread connection is provided on both ends of the terminal box. This connection will readily accept common electrical quick disconnect assemblies on the market. The wiring housing is available with most options.

Solenoid Indicator Lights

Light is "on" when there is current at the solenoid coil. Lights are available for various voltages in both AC and DC service.

Pilot Valve Operating Data

| Feature | Standard Performance Valve DG4V-3S-*-60 | | High Performance Valve DG4V-3-*-60 | |
|--|---|---------------------|---------------------------------------|---------------------|
| Electrical Protection | | | | |
| ISO 4400 coils w/plug | IEC 144 class IP65 | | IEC 144 class IP65 | |
| Conduit box | IEC 144 class IP65 | | IEC 144 class IP65 | |
| Vickers Insta-Plug | IEC 144 class IP50 | | IEC 144 class IP50 | |
| Coil Winding | Class H | | Class H | |
| Lead wires (coil type F) | Class H | | Class H | |
| Coil encapsulation | Class F | | Class F | |
| Typical response times at 100% rated volts measured from application/removal of voltage to full spool displacement of 2C spool at: | | | | |
| Flow rate P to A, B to T | 20 l/min (5.3 USgpm) | | 40 l/min (10.6 USgpm) | |
| Pressure | 175 bar (2538 psi) | | 175 bar (2538 psi) | |
| AC energizing | 18 ms | | 15 ms | |
| AC de-energizing | 32 ms | | 23 ms | |
| DC energizing | 60 ms | | 45 ms | |
| DC de-energizing | 40 ms | | 28 ms | |
| Power consumption, AC solenoids | Initial ♦ VA (RMS) | Holding VA (RMS) | Initial ♦ VA (RMS) | Holding VA (RMS) |
| Full power coils: | | | | |
| Single frequency coils AC 50 Hz | 225 | 39 | 225 | 54 |
| Dual frequency coils at 50 Hz | 265 | 49 | 280 | 61 |
| Dual frequency coils at 60 Hz | 260 | 48 | 300 | 58 |
| Low power coils, "B" & "D": | | | | |
| Dual frequency coils at 50 Hz | Low power coils not usable with DG4V-3S valves. | | 170 | 37 |
| Dual frequency coils at 60 Hz | | | 190 | 37 |
| Power consumption, DC solenoids | | | | |
| Full power coils: | | | | |
| 12V, model type "G" | 30W | – | 30W | – |
| 24V, model type "H" | 30W | – | 30W | – |
| Low power coils, "B" & "D": | | | | |
| 12V, model code "G" | Low power coils not usable with DG4V-3S valves. | | 18W | – |
| 24V, model code "H" | | | 18W | – |

♦ First half cycle; armature fully retracted.

Electrical Connectors

DIN Standard 43650 Plug-in Connectors

Plug connector
(Order separately)
(ISO4400/DIN 43650)

Cable diameter range: Ø6–10 mm (0.24–0.40)
Wire section range: Ø,5–1,5 mm² (0.0008–0.0023 in²)
Terminals: Screw type
Type of protection: IEC144 class IP65, when plugs are fitted correctly to the valves with the interface seals (supplied with plugs) in place.

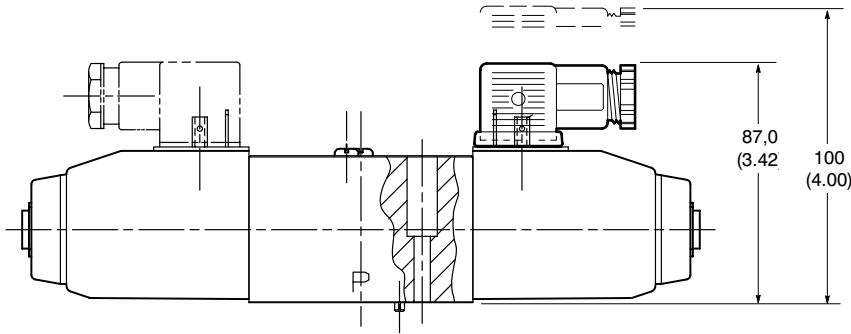

Connector can be positioned at 90° intervals on valve by re-assembling contact holder into appropriate position inside connector housing.

Connectors with and without indicator lights are available (order separately):

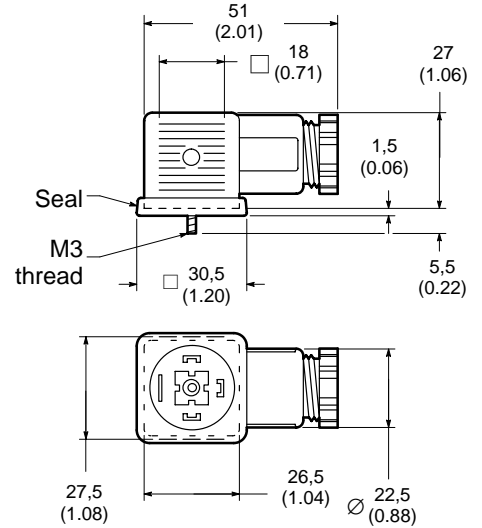

| Receptacle | Voltage (AC or DC) | Gray – “A” sol. | Black – “B” sol. |
|-------------------|-----------------------|--------------------|---------------------|
| Without lights | — | 710776 | 710775 |
| With lights | 12–24 | 977467 | 977466 |
| | 100–125 | 977469 | 977468 |
| | 200–240 | 977471 | 977470 |

Electrical Connectors

Insta-Plug Option

Vickers "Insta-Plug" provides a means of disconnecting electrical power to the valve without actually breaking individual wire connections. The male half of the plug is attached to the top of the valve body. Solenoid leads are connected to this half of the plug by Vickers. The mating plug is attached inside the wire housing. Terminals are provided on top of it for the convenience of connecting machine wires.

Two thumb screws are used to hold the wiring housing with the female plug half to the valve. These screws are captive to avoid loss when servicing. To disconnect the valve they are loosened until clear, allowing the wiring housing to be pulled away from the valve body; thereby disconnecting electrical power to the valve. Note that the ground fifth post is longer than the other four, providing a first-make/last-break ground feature.

The **PB** configuration includes both the male and female (retained in the housing) halves for a complete plug-in unit.

Solenoid indicator lights can also be furnished with the Insta-Plug feature. When furnished, the lights are pre-wired to the female half of the plug. Solenoids A and/or B are identified on the identification plate attached to the wiring housing.

Millimeters (inches)

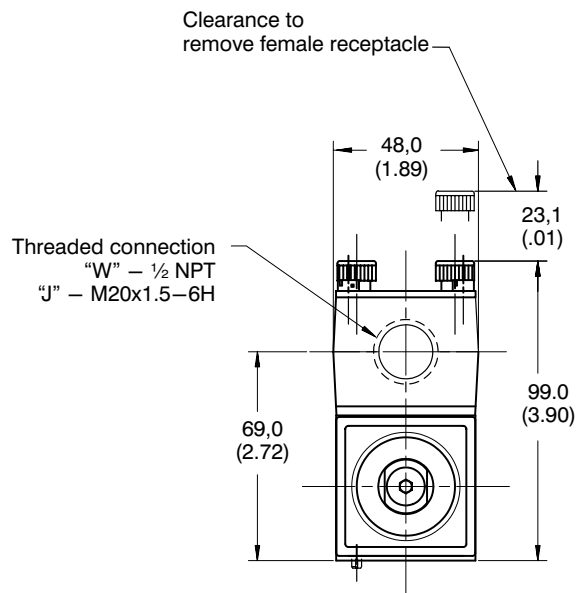
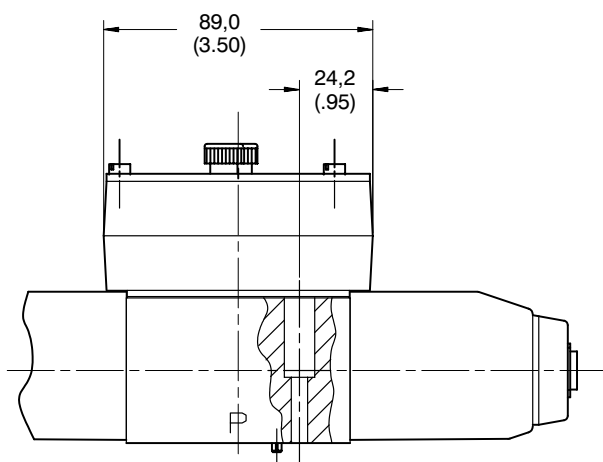

Electrical Connectors

NFPA Hydraulic Valve Electrical Connector

The receptacle is a standard three or five pole electrical connector with shortened leads and terminals added.

The five pole plug has four leads 101,6 mm (4.0") long and one 177,8 mm (7.0") long. The three pole plug has two leads 101,6 mm (4.0") long and one 177,8 mm (7.0") long.

All of the wires have Underwriters recognized non-solder insulated eyelet terminals. The #4 and #2 leads are attached to the "A" solenoid, and the #5 and #1 leads are attached to the "B" solenoid. The green wire is used for the ground connection (#8 screw furnished).

Electrical Connector Plug

Millimeters (inches)

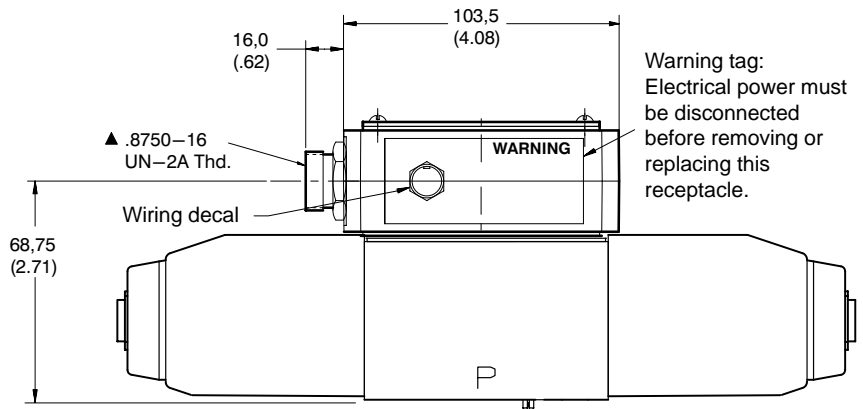
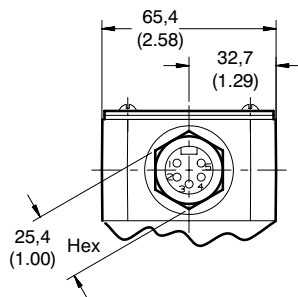

Warning tag: Electrical power must be disconnected before removing or replacing this receptacle.

Models DG5S4-04**-M-PA*-W-*-60/70

Electrical Plug Feature
 PA3 - NFPA 3-pin conduit connector
 PA5 - NFPA 5-pin conduit connector

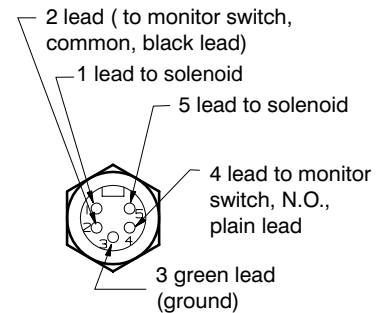
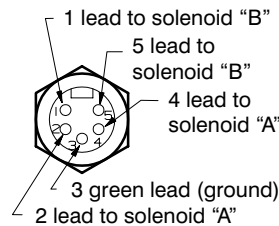
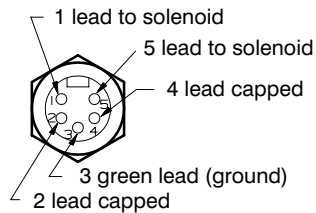
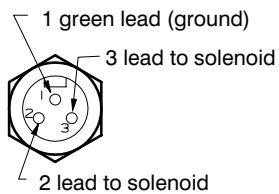

▲ Electrical connection is over solenoid on single solenoid models, and over "b" solenoid on dual solenoid models. See diagram plate for "b" solenoid location.

Electrical rating 600 volts, 3 pole, 10 amps and 5 pole, 8 amps. The female portable plug to be furnished by customer.

Application Data

Fluid Cleanliness

Proper fluid condition is essential for long and satisfactory life of hydraulic components and systems. Hydraulic fluid must have the correct balance of cleanliness, materials, and additives for protection against wear of components, elevated viscosity, and inclusion of air.

Essential information on the correct methods for treating hydraulic fluid is included in Vickers publication 561 "Vickers Guide to Systemic Contamination Control" available from your local Vickers distributor or by

contacting Vickers, Incorporated. Recommendations on filtration and the selection of products to control fluid condition are included in 561.

Recommended cleanliness levels, using petroleum oil under common conditions, are based on the highest fluid pressure levels in the system and are coded in the chart below. Fluids other than petroleum, severe service cycles, or temperature extremes are cause for adjustment of these cleanliness codes. See Vickers publication 561 for exact details.

Vickers products, as any components, will operate with apparent satisfaction in fluids with higher cleanliness codes than those described. Other manufacturers will often recommend levels above those specified. Experience has shown, however, that life of any hydraulic component is shortened in fluids with higher cleanliness codes than those listed below. These codes have been proven to provide a long, trouble-free service life for the products shown, regardless of the manufacturer.

| Product | System Pressure Level bar (psi) | | |
|------------------------------|------------------------------------|--------------------|-----------------|
| | <70 (<1000) | 70-210 (1000-3000) | 210+ (3000+) |
| Vane Pumps – Fixed | 20/18/15 | 19/17/14 | 18/16/13 |
| Vane Pumps – Variable | 18/16/14 | 17/15/13 | |
| Piston Pumps – Fixed | 19/17/15 | 18/16/14 | 17/15/13 |
| Piston Pumps – Variable | 18/16/14 | 17/15/13 | 16/14/12 |
| Directional Valves | 20/18/15 | 20/18/15 | 19/17/14 |
| Pressure/Flow Control Valves | 19/17/14 | 19/17/14 | 19/17/14 |
| CMX Valves | 18/16/14 | 18/16/14 | 17/15/13 |
| Servo Valves | 16/14/11 | 16/14/11 | 15/13/10 |
| Proportional Valves | 17/15/12 | 17/15/12 | 15/13/11 |
| Cylinders | 20/18/15 | 20/18/15 | 20/18/15 |
| Vane Motors | 20/18/15 | 19/17/14 | 18/16/13 |
| Axial Piston Motors | 19/17/14 | 18/16/13 | 17/15/12 |
| Radial Piston Motors | 20/18/14 | 19/17/13 | 18/16/13 |

Алматы (7273)495-231
Ангарск (3955)60-70-56
Архангельск (8182)63-90-72
Астрахань (8512)99-46-04
Барнаул (3852)73-04-60
Белгород (4722)40-23-64
Благовещенск (4162)22-76-07
Брянск (4832)59-03-52
Владивосток (423)249-28-31
Владикавказ (8672)28-90-48
Владимир (4922)49-43-18
Волгоград (844)278-03-48
Вологда (8172)26-41-59
Воронеж (473)204-51-73
Екатеринбург (343)384-55-89

Иваново (4932)77-34-06
Ижевск (3412)26-03-58
Иркутск (395)279-98-46
Казань (843)206-01-48
Калининград (4012)72-03-81
Калуга (4842)92-23-67
Кемерово (3842)65-04-62
Киров (8332)68-02-04
Коломна (4966)23-41-49
Кострома (4942)77-07-48
Краснодар (861)203-40-90
Красноярск (391)204-63-61
Курск (4712)77-13-04
Курган (3522)50-90-47
Липецк (4742)52-20-81

Магнитогорск (3519)55-03-13
Москва (495)268-04-70
Мурманск (8152)59-64-93
Набережные Челны (8552)20-53-41
Нижний Новгород (831)429-08-12
Новокузнецк (3843)20-46-81
Ноябрьск (3496)41-32-12
Новосибирск (383)227-86-73
Омск (3812)21-46-40
Орел (4862)44-53-42
Оренбург (3532)37-68-04
Пенза (8412)22-31-16
Петрозаводск (8142)55-98-37
Псков (8112)59-10-37
Пермь (342)205-81-47

Ростов-на-Дону (863)308-18-15
Рязань (4912)46-61-64
Самара (846)206-03-16
Санкт-Петербург (812)309-46-40
Саратов (845)249-38-78
Севастополь (8692)22-31-93
Саранск (8342)22-96-24
Симферополь (3652)67-13-56
Смоленск (4812)29-41-54
Сочи (862)225-72-31
Ставрополь (8652)20-65-13
Сургут (3462)77-98-35
Сыктывкар (8212)25-95-17
Тамбов (4752)50-40-97
Тверь (4822)63-31-35

Тольятти (8482)63-91-07
Томск (3822)98-41-53
Тула (4872)33-79-87
Тюмень (3452)66-21-18
Ульяновск (8422)24-23-59
Улан-Удэ (3012)59-97-51
Уфа (347)229-48-12
Хабаровск (4212)92-98-04
Чебоксары (8352)28-53-07
Челябинск (351)202-03-61
Череповец (8202)49-02-64
Чита (3022)38-34-83
Якутск (4112)23-90-97
Ярославль (4852)69-52-93

Россия +7(495)268-04-70

Казахстан +7(7172)727-132

Киргизия +996(312)96-26-47