

Алматы (7273)495-231  
 Ангарск (3955)60-70-56  
 Астрахань (8182)63-90-72  
 Барнаул (3852)73-04-60  
 Белгород (4722)40-23-64  
 Благовещенск (4162)22-76-07  
 Брянск (4832)59-03-52  
 Владивосток (423)249-28-31  
 Владикавказ (8672)28-90-48  
 Владимир (4922)49-43-18  
 Волгоград (844)278-03-48  
 Вологда (8172)26-41-59  
 Воронеж (473)204-51-73  
 Екатеринбург (343)384-55-89

Иваново (4932)77-34-06  
 Ижевск (3412)26-03-58  
 Иркутск (395)279-98-46  
 Казань (843)206-01-48  
 Калининград (4012)72-03-81  
 Калуга (4842)92-23-67  
 Кемерово (3842)65-04-62  
 Киров (8332)68-02-04  
 Коломна (4966)23-41-49  
 Кострома (4942)77-07-48  
 Краснодар (861)203-40-90  
 Красноярск (391)204-63-61  
 Курск (4712)77-13-04  
 Курган (3522)50-90-47  
 Липецк (4742)52-20-81

Магнитогорск (3519)55-03-13  
 Москва (495)268-04-70  
 Мурманск (8152)59-64-93  
 Набережные Челны (8552)20-53-41  
 Нижний Новгород (831)429-08-12  
 Новокузнецк (3843)20-46-81  
 Ноябрьск (3496)41-32-12  
 Новосибирск (383)227-86-73  
 Омск (3812)21-46-40  
 Орел (4862)44-53-42  
 Оренбург (3532)37-68-04  
 Пенза (8412)22-31-16  
 Петрозаводск (8142)55-98-37  
 Псков (8112)59-10-37  
 Пермь (342)205-81-47

Ростов-на-Дону (863)308-18-15  
 Рязань (4912)46-61-64  
 Самара (846)206-03-16  
 Санкт-Петербург (812)309-46-40  
 Саратов (845)249-38-78  
 Севастополь (8692)22-31-93  
 Саранск (8342)22-96-24  
 Симферополь (3652)67-13-56  
 Смоленск (4812)29-41-54  
 Сочи (862)225-72-31  
 Ставрополь (8652)20-65-13  
 Сургут (3462)77-98-35  
 Сыктывкар (8212)25-95-17  
 Тамбов (4752)50-40-97  
 Тверь (4822)63-31-35

Тольятти (8482)63-91-07  
 Томск (3822)98-41-53  
 Тула (4872)33-79-87  
 Тюмень (3452)66-21-18  
 Ульяновск (8422)24-23-59  
 Улан-Удэ (3012)59-97-51  
 Уфа (347)229-48-12  
 Хабаровск (4212)92-98-04  
 Чебоксары (8352)28-53-07  
 Челябинск (351)202-03-61  
 Череповец (8202)49-02-64  
 Чита (3022)38-34-83  
 Якутск (4112)23-90-97  
 Ярославль (4852)69-52-93

Россия +7(495)268-04-70

Казахстан +7(7172)727-132

Киргизия +996(312)96-26-47

<https://vickers.nt-rt.ru> || [vsh@nt-rt.ru](mailto:vsh@nt-rt.ru)

## DG3V-7, 20 Series, Pilot Operated DG5V-7, 40 Series, Solenoid Controlled, Pilot Operated ISO 4401 Size 07

### Typical Section

DG5V-7-2C Spring-Centered Valve Example

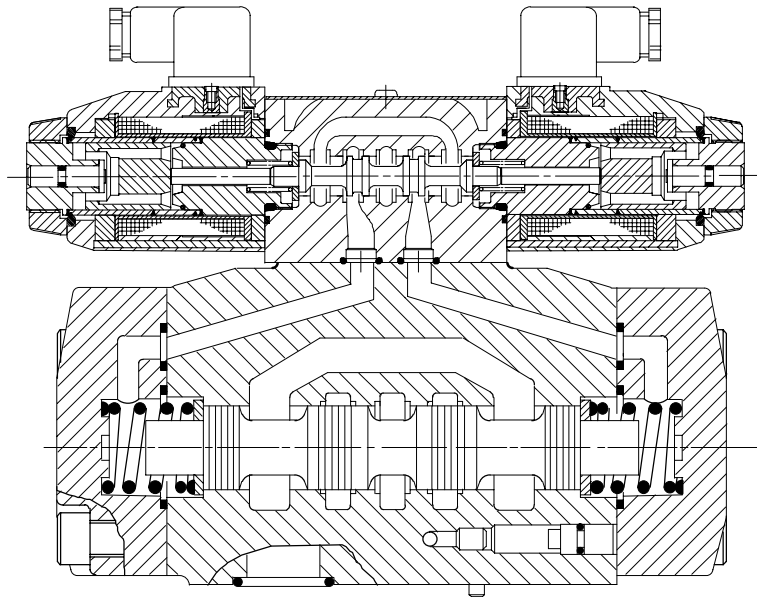

### Basic Characteristics

Mounting . . . . . Surface mounting  
 Max. pressure . . . . . 350 bar (5000 psi)  
 Max. flow . . . . . 300 L/min (80 USgpm)

### General Description

DG\*V-7 valves are used primarily for controlling the starting, stopping and direction of fluid flow.

Two series of valves, DG5V solenoid controlled, pilot operated and DG3V pilot operated models are available with a choice of 18 different spools. These include meter-in and meter-out spools and a regeneration type that can obviate extra valves essential in traditional circuit arrangements. All spools have been designed to provide good low shock, fast response characteristics which can be enhanced by optional stroke and/or pilot choke adjustments.

Models include spring offset, spring centered, pressure centered and detented versions. All are available with the option of an integral P-port pilot pressure generator. DG5V valves can be arranged for internal or external pilot pressure and/or drain connections.

### Features and Benefits

- High pressure and flow capability for maximum cost-effectiveness.
- Low headloss to minimize power wastage.
- Low shock characteristics to maximize machine life.
- Facility to change solenoid coils without disturbing the hydraulic envelope.
- The many optional features, particularly for DG5V valves, permit matching to virtually every application within the valve's power capacity.

# Functional Symbols

## DG3V-7 Pilot Operated Models

Comprehensive and simplified symbols.

### Spring Offset, End-to-End, DG3V-7-\*A

Spool types: 0, 2, 6, 9, 52, 521, X2▲, Y2▲

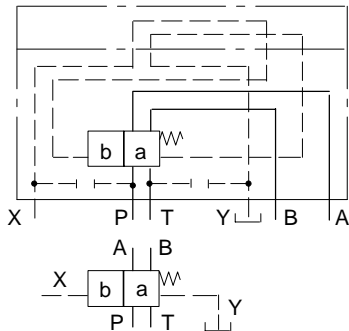

### Spring Offset, End-to-End, Opposite Hand, DG3V-7-\*AL

Spool types: 0, 2, 6, 9, 52, 521, X2▲, Y2▲

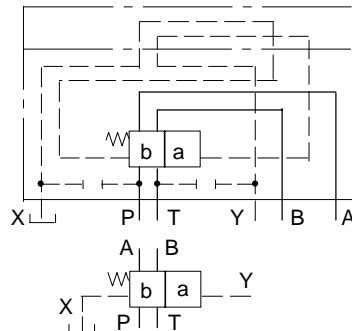

### Spring Centered, DG3V-7-\*C

Spool types: All ▲

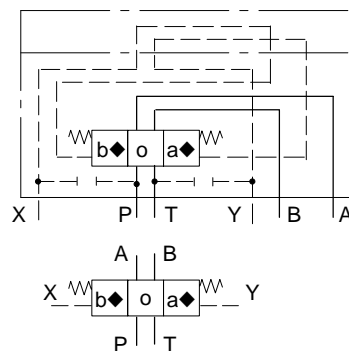

### Pressure Centered, DG3V-7-\*D

Spool types: All ▲

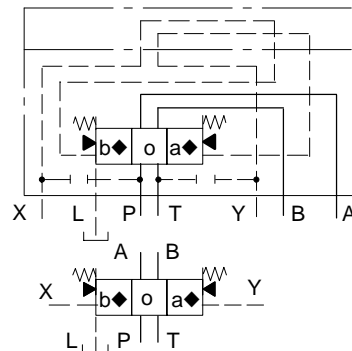

## DG3V-7 Options

The following are shown in a DG3V-7-\*C example:

1. Pilot choke module
2. Minimum pilot pressure generator
3. Stroke adjusters at either or at both ends (shown at both ends in example)

One or more options can be built into any DG3 series valve.

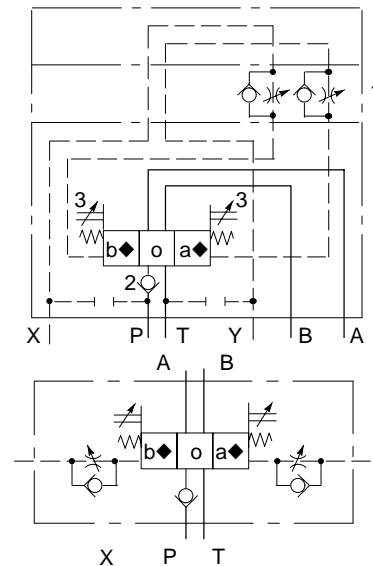

## DG5V-7, Solenoid Controlled, Pilot Operated Models

Comprehensive and simplified symbols, shown configured for external pilot supply and internal drain.

### Spring Offset, End-to-End, DG5V-7-\*A

Spool types: 0, 2, 6, 9, 52, 521, X2▲, Y2▲

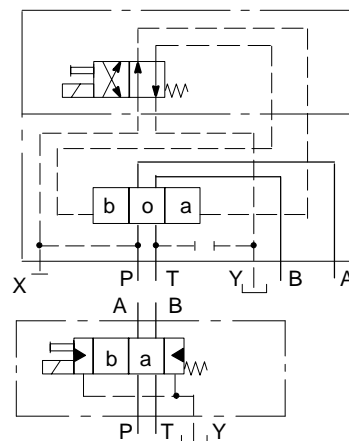

### Spring Offset, End-to-End, Opposite Hand, DG5V-7-\*AL

Spool types: 0, 2, 6, 9, 52, 521, X2▲, Y2▲

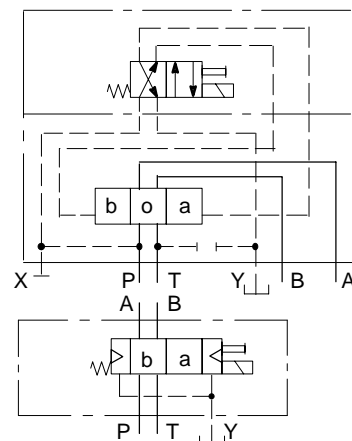

- ◆ "a" and "b" interchanged for spool types 4 and 8.
- ▲ "X" and "Y" spools require a stroke adjuster at one or both ends, dependent on the application, to limit stroke towards "a" and/or "b".

**Spring Offset, End-to-Center**

Models Spool types  
 DG5V-7-\*B 0, 2, 52, 521, X2▲, Y2▲  
 DG5V-7-\*BL 4, 8

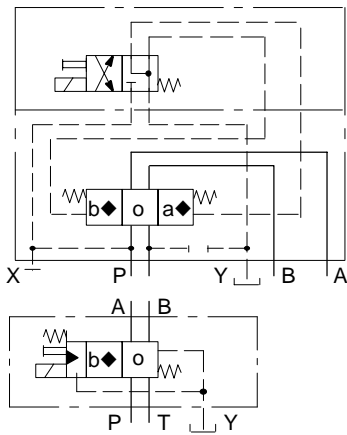

**Spring Offset, End-to-Center, Opposite Hand**

Models Spool types  
 DG5V-7-\*B 4, 8  
 DG5V-7-\*BL 0, 2, 52, 521, X2▲, Y2▲

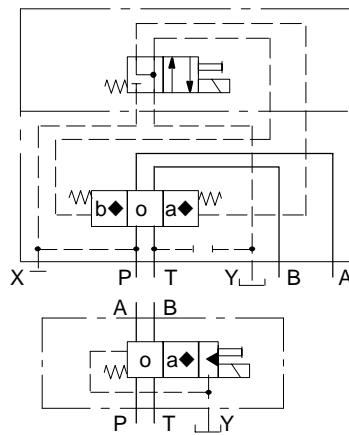

**Spring Centered, DG5V-7-\*C**

Spool types: All

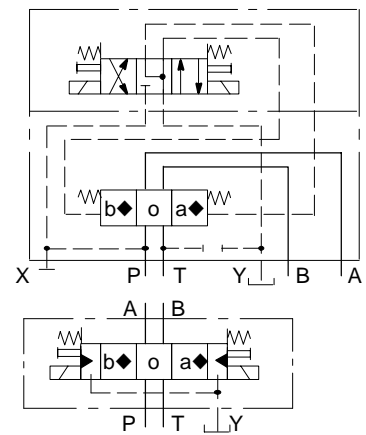

**Pressure Centered, DG5V-7-\*D**

Spool types: All

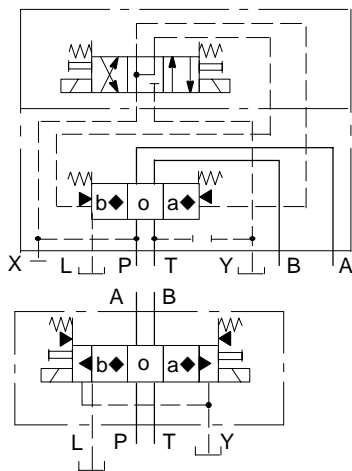

**Detented, DG5V-7-\*N**

Spool types: 0, 2, 6, 9, 52, 521, X2▲, Y2▲

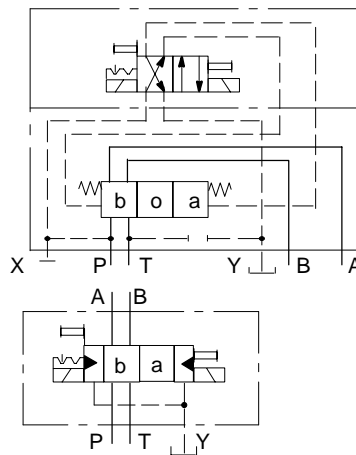

**DG5V-7 Options**

The following are shown in a DG5V-7-\*C example:

1. Pilot choke module
2. Minimum pilot pressure generator
3. Stroke adjusters, at either or at both ends (shown at both ends in example)
4. External pilot connection
5. Internal drain

One or more options can be built into any DG5 series valve, the only exception being that the internal drain option is not available with DG5V-7-\*D (pressure centered) valves.

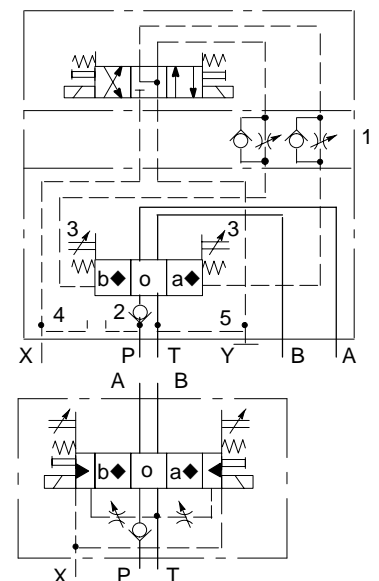

◆ "a" and "b" interchanged for spool types 4 and 8.  
 ▲ "X" and "Y" spools require a stroke adjuster at one or both ends, dependent on the application, to limit stroke towards "a" and/or "b".

## Symbols on Nameplates

Typical illustrations for:

DG3V-7-2D-1

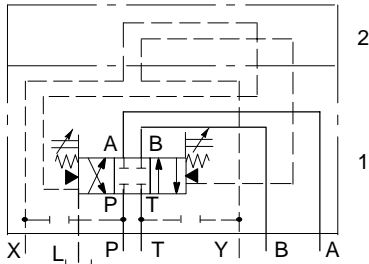

1. On main stage
2. On cover plate

### Notes:

- a. For clarity pilot lines (dotted lines in illustrations) are omitted from the main-stage nameplate.
- b. Where a minimum pilot pressure generator (check valve symbol) is provided the letter P is omitted from the nameplate for clarity.

DG5V-7-3C-2-E-T-K

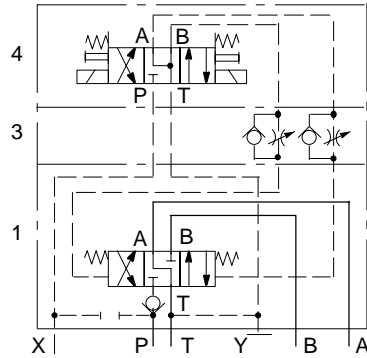

1. On main stage
3. On pilot choke module
4. On pilot stage valve

## Spool Types

Shown in 3-position form, plus 2 transients

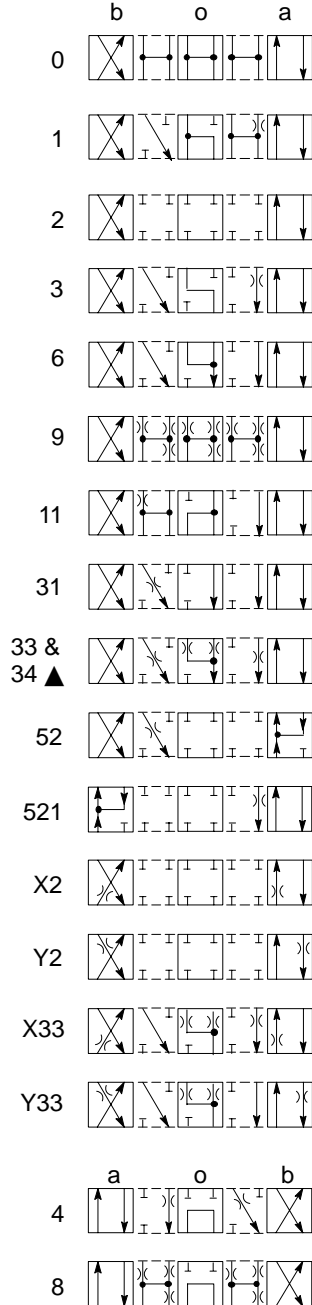

### Notes:

1. In the detailed and simplified symbols on this and the previous pages, the transient positions are omitted for simplicity.
  2. In certain 2-position valves, the "o" position becomes an additional transient, i.e. in DG5V-7-\*A(L) and DG5V-7-\*N valves.
- ▲ The performance of the "33" and "34" spools differ only in the center position. Your Vickers representative can provide further details.

# Application Notes

---

## Pilot Pressure

- a. Pilot pressure must always exceed tank line pressure by at least the requisite minimum pilot pressure. This also applies when combining open-center spools (0, 1, 4, 8, 9 and 11) with internal pilot pressure, but they should be used only with externally drained valves.
- b. Internally drained valves may be used only when surges in the tank line cannot possibly overcome the minimum pilot pressure differential referred to above. When the possibility of pressure surges in the tank line exist, externally drained valves are recommended.
- c. When DG5V-7-\*N valves are de-energized the pilot and main spools remain in the last selected position, provided that pilot pressure is maintained. If pilot pressure fails, or falls below the minimum, the main spool will spring center.

*Caution: Because of this in-built feature the flow conditions of the center position must be selected with care, for the effect on both the direction of flow and the pilot pressure.*

## Minimum-Pilot-Pressure Generator Option

Can be built into the P-port to create a minimum pilot pressure differential of 0,35 bar (5 psi) where internal pilot pressure is required with open-centered spools, i.e. 0, 1, 4, 8, 9 and 11.

## Stroke Adjustment Options

These control the maximum opening of the main spool/body passages by adjusting the limits of spool stroke. By this means, the response time and the pressure drop across the valve for any particular flow rate can be controlled. Stroke adjusters can be fitted at either or both ends of the main-stage valve for adjusting the stroke in one or both directions. One use of stroke adjusters is for controlling the metering characteristics of "X\*" or "Y\*" type spools. (See model code 4.)

## Pilot Choke Adjustment Options

These provide a meter-out flow control system to the fluid in the pilot chambers of main-stage valves. It allows the velocity of the main-stage spool to be controlled, thereby reducing transient shock condition. For optimum results, a constant reduced pilot pressure is recommended.

## Control Data, General

- a. Dependent on the application and the system filtration, any sliding spool valve, if held shifted under pressure for long periods of time, may stick and not move readily due to fluid residue formation. It may therefore need to be cycled periodically to prevent this from happening.
- b. Surges of fluid in a common drain line serving two or more valves can be of sufficient magnitude to cause inadvertent shifting of the spools. It is recommended that circuit protection be used, such as separate drain lines.
- c. Control by stroke adjusters, pilot chokes and minimum-pilot-pressure generator options is described on this page.

# Model Code

For pilot operated valves:

**(F3-) DG3V-7-\* \*\* (-\*\*) (-K)-2\***

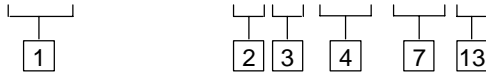

For solenoid controlled, pilot operated valves:

**(F3-) DG5V-7-\* \*\* (-\*\*) (-E)(-T)(-K) (-\*)-(V) M-\*\*\*\*\* (L)-\* 5-4\***

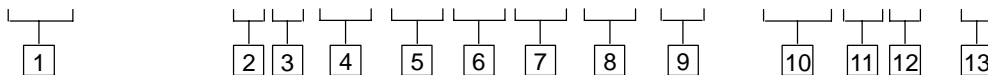

## 1 Fluid compatibility

Blank = Antiwear hydraulic oil (class L-HM), invert emulsion (class L-HFB), or water glycol (class L-HFC)

F3 = As above or phosphate ester (class L-HFD)

Note: For further information see "Hydraulic Fluids" section on page A.12.

## 2 Spool type

See "Functional Symbols" section on page A.2.

## 3 Spool spring arrangement

A = Spring offset, end-to-end (P to B when operated)

AL = As "A" but left-hand build (P to A when operated)

B = Spring offset, end-to-center (P to B when operated)■

BL = As "B" but left-hand build (P to A when operated)■

C = Spring centered

D = Pressure centered

N = Two-position detented

■ DG5V option. Same function from DG3V-7-\*C valves by alternating pilot supply to one port (X or Y) and permanently draining the other.

## 4 Spool control

1 = Stroke adjustment at both ends▲

2 = Pilot choke adjustment both ends

3 = "1" and "2" combined▲

7 = Stroke adjustment, port A end only◆

8 = Stroke adjustment, port B end only▼

27 = "2" and "7" combined▼

28 = "2" and "8" combined◆

Omit if not required

▲ Not applicable to DG5V-7-\*B(L) models.

▼ Not applicable to models shown in the "Spring offset, end-to-center, opposite hand" section on page A.3.

◆ Not applicable to models shown in the "Spring offset, end-to-center" section on page A.3.

## 5 External pilot supply, DG5V valve option

Omit for internal pilot supply

## 6 Internal pilot drain, DG5V valve option

Omit for external drain, which is also mandatory for 1, 4, 8 and 9 spool-type valves

## 7 Minimum-pilot-pressure generator ("P" port option)

K = 0,35 bar (5 psi) cracking pressure

Omit if not required

## 8 Manual override option

Blank = Plain override in solenoid end(s) only▲

H = Water-resistant manual override on solenoid end(s)▲

Z = No override at either end

▲ No override in non-solenoid end of single-solenoid valves.

## 9 Solenoid energization identity

V = Solenoid "A" is at port A end of pilot valve and/or solenoid "B" at port B end independent of main-stage valve port locations or spool type; German practice.

Omit (except as noted below) for US ANSI B93.9 standard whereby solenoid "A" is that which, when energized, connects P to A in main-stage valve, and/or solenoid "B" connects P to B.

Note: Energization identities on valves with type 4 or 8 spools are identical under US and German practices. In such cases the "V" code is used.

## 10 Solenoid type/connection(s)

U = ISO 4400 (DIN 43650) mounting■

FW = 1/2" NPT thread junction box

FTW = 1/2" NPT thread junction box and terminal strip

FJ = M20 thread junction box

FTJ = M20 thread junction box and terminal strip

FPA3W = Junction box with 3-pin male connector◆ to NFPA T3.5.29-1980 for single-solenoid valves

FPA5W = Junction box with 5-pin male connector◆ to NFPA T3.5.29-1980 for single or double-solenoid valves

■ Some female plug connector options available separately from Vickers Systems (see "Plugs for ISO 4400" on page A.16). Others available from electrical stockists.

◆ Female connector to be supplied by user.

---

**11 Indicator lights, option for codes FTJ, FTW, FPA3W and FPA5W in 10**

L = Lights fitted

Omit if lights not required

For U-code solenoids use plug with integral light, see page A.16.

---

**12 Coil rating**

See "Operating Data" on page A.8 for further information.

A = 110V AC 50 Hz

B◆ = 110V AC 50 Hz/  
120V AC 60 Hz

C = 220V AC 50 Hz

D◆ = 220V AC 50 Hz/  
240V AC 60 Hz

G = 12V DC

H = 24V DC

◆ For 60 Hz or dual frequency.

**13 Design number**

20 series for DG3V valves.

40 series for DG5V valves.

Subject to change. Installation dimensions unaltered for design numbers \*0 to \*9 inclusive.

---

**For Mounting Subplate and Fastener Kit Options**

See "Supporting products" on page A.10.

**For ISO 4400 (DIN 43650) Electrical Plugs to Suit DG5V---(V)M-U Valves**

See "Installation Dimensions" and "Electrical Plugs and Connectors" on page A.13.

# Operating Data

Performance data typical under standard test conditions which use antiwear hydraulic oil (Class L-HM) at 21 cSt (102 SUS) and 50°C (122°F).

<p>Maximum pressures:</p> <p>DG3V-7 valves; ports: P, A, B, T, X and Y L</p> <p>DG5V-7-**(L)(-*)(-E)(-*) valves, (externally drained); ports: P, A, B, T and X Y L</p> <p>DG5V-7-**(L)(-*)(-E)-T(-*) valves, (internally drained); ports: P, A, B and X T</p> <p>◆ Available for all except the DG5V-7-D pressure centered models</p>	<p>350 bar (5000 psi) 0,5 bar (7 psi)</p> <p>350 bar (5000 psi)▲ 100 bar (1500 psi)▲ 0,5 bar (7 psi)</p> <p>350 bar (5000 psi)▲ 100 bar (1500 psi)▲</p> <p>▲ The DG5V, 40 design two-stage valves have been designed to satisfy the needs of most applications. Consult your Vickers representative about an alternative model if: a) Valves are required to remain pressurized for long periods without frequent switching, and /or b) Back pressure on the drain port of externally drained models (or the tank port of internally drained models) is required to rise above 100 bar (1500 psi).</p>								
<p>Maximum flow rates, L/min (USgpm) at the minimum pilot pressures (see "Pilot Pressures" on page A.11) ■, and with spool type: 0, 2, 3, 6, 31, 33, 52 or 521◆ 1, 4, 9 or 11 8</p> <p>■ Higher flow rates possible at higher pilot pressures; consult your local Vickers sales engineer. ◆ Consult your local Vickers sales engineer regarding flow limits relative to the regenerative position of type 52 and 521 spools.</p>	<p>At system pressure, bar (psi) of: 70 (1000) 140 (2000) 210 (3000) 280 (4060) 350 (5000)</p> <p>300 (80) 300 (80) 300 (80) 300 (80) 300 (80) 260 (69) 220 (58) 120 (32) 100 (26) 90 (24) 300 (80) 300 (80) 250 (66) 165 (44) 140 (37)</p>								
Pilot pressures	See "Pilot Pressures" on page A.11.								
Control (swept) volume(s), DG3V and main-stage of DG5V valves: Center-to-end End-to-end	4,07 cm <sup>3</sup> (0.25 in <sup>3</sup> ) 8,14 cm <sup>3</sup> (0.50 in <sup>3</sup> )								
Voltage ratings, DG5V valves	See <a href="#">12</a> in "Model Code" on page A.7.								
Voltage limits, DG5V valves: Maximum voltage Minimum voltage	See "Temperature limits", on page A.9. 90% of rated voltage								
Power consumption, DG5V valves with AC solenoids: Single-frequency coils, 50 Hz types "A" and "C" Dual-frequency coils at 50 Hz, types "B" and "D" Dual-frequency coils at 60 Hz, types "B" and "D"	<table> <thead> <tr> <th>Initial VA rms</th> <th>Holding VA rms</th> </tr> </thead> <tbody> <tr> <td>225</td> <td>39</td> </tr> <tr> <td>265</td> <td>49</td> </tr> <tr> <td>260</td> <td>48</td> </tr> </tbody> </table>	Initial VA rms	Holding VA rms	225	39	265	49	260	48
Initial VA rms	Holding VA rms								
225	39								
265	49								
260	48								
Power consumption, DG5V valves with DC solenoids	30W at rated voltage and 20°C (68°F)								
Relative duty factor, DG5V valves	Continuous; ED = 100%								
Type of protection, DG5V valves: ISO 4400 coils with plug fitted correctly Junction box Coil winding Lead wires (coil types "F****") Coil encapsulation	IEC 144 class IP65 IEC 144 class IP65 (NEMA 4) Class H Class H Class F								

Continued on next page



Pressure drop characteristics	See page A.11.																																				
<p>Response times, DG5V valves:  Typical values for a DG5V-7-2C-E spring centered, externally piloted valve under standard test conditions and operating with 150 L/min (40 USgpm) at 350 bar (5000 psi).</p> <table border="0"> <thead> <tr> <th>Coil rating:</th> <th>Pilot pressure, bar (psi):</th> <th>Energizing:</th> <th>Time, ms◆</th> </tr> </thead> <tbody> <tr> <td rowspan="5">110V 50 Hz</td> <td>15 (218)</td> <td>120</td> <td>55</td> </tr> <tr> <td>50 (730)</td> <td>45</td> <td>55</td> </tr> <tr> <td>150 (2180)</td> <td>25</td> <td>55</td> </tr> <tr> <td>210 (3000)</td> <td>20</td> <td>55</td> </tr> <tr> <td>250 (3600)</td> <td>18</td> <td>55</td> </tr> <tr> <td rowspan="5">24V DC</td> <td>15 (218)</td> <td>130</td> <td>65▲</td> </tr> <tr> <td>50 (730)</td> <td>55</td> <td>65▲</td> </tr> <tr> <td>150 (2180)</td> <td>35</td> <td>65▲</td> </tr> <tr> <td>210 (3000)</td> <td>30</td> <td>65▲</td> </tr> <tr> <td>250 (3600)</td> <td>28</td> <td>65▲</td> </tr> </tbody> </table> <p>◆ From applying a signal at the solenoid until the main-stage spool completes its travel.  ▲ In pure switched circuit conditions, devoid of the effects of any suppression diodes and full-wave rectifiers.</p>	Coil rating:	Pilot pressure, bar (psi):	Energizing:	Time, ms◆	110V 50 Hz	15 (218)	120	55	50 (730)	45	55	150 (2180)	25	55	210 (3000)	20	55	250 (3600)	18	55	24V DC	15 (218)	130	65▲	50 (730)	55	65▲	150 (2180)	35	65▲	210 (3000)	30	65▲	250 (3600)	28	65▲	See "Response Times" section on page A.12.
Coil rating:	Pilot pressure, bar (psi):	Energizing:	Time, ms◆																																		
110V 50 Hz	15 (218)	120	55																																		
	50 (730)	45	55																																		
	150 (2180)	25	55																																		
	210 (3000)	20	55																																		
	250 (3600)	18	55																																		
24V DC	15 (218)	130	65▲																																		
	50 (730)	55	65▲																																		
	150 (2180)	35	65▲																																		
	210 (3000)	30	65▲																																		
	250 (3600)	28	65▲																																		
<p>Temperature limits:  Fluid temperature limits  Ambient temperature limits:  Minimum ambient, all valves</p> <p>Maximum ambients, DG5V valves with coils listed in <a href="#">12</a> in "Model Code" two pages back, and under conditions stated below:  Dual-frequency coils:  at 50 Hz and 107% of rated voltage  at 50 Hz and 110% of rated voltage  at 60 Hz and 107% of rated voltage  at 60 Hz and 110% of rated voltage</p> <p>Single-frequency (50 Hz) coils at 50 Hz and 110% of rated voltage</p> <p>DC coils at 110% of rated voltage</p>	<p>See on page A.12.</p> <p>–20°C (–4°F)</p> <p>65°C (150°F)  65°C (150°F)  65°C (150°F)  65°C (150°F)</p> <p>65°C (150°F)</p> <p>70°C (158°F)</p>																																				
<p>Installation dimensions:  Valves  Mounting surface</p>	<p>See page A.13.  See catalog 2425</p>																																				
<p>Mass (weight), basic models:  DG3V-7-*A(L)  DG3V-7-*B(L)/*C  DG3V-7-*D  DG5V-7-*A/B (AC voltages)  DG5V-7-*A/B (DC voltages)  DG5V-7-*C/N (AC voltages)  DG5V-7-*C/N (DC voltages)  DG5V-7-*D (AC voltages)  DG5V-7-*D (DC voltages)</p>	<p>kg (lb)approx.  10,0 (22.0)◆  7,3 (16.1)◆  8,4 (18.5)◆  8,4 (18.5)◆  8,5 (18.7)◆  8,7 (19.2)◆  9,1 (20.0)◆  9,8 (21.6)◆  10,2 (22.5)◆  ◆ Add 1,1 kg (2.4 lb) when pilot choke adjustment is fitted.</p>																																				

Continued on next page

<p>Supporting products:  Subplate  Fastener kits</p>	<p>See catalog 2425  See catalog 2314 for available metric bolt kit options,  i.e. BKDG7-858918 and BKDG7-858919.</p>
<p>Installation and start-up (commissioning):  Mounting attitudes, DG3V series  Mounting attitudes, DG5V series</p>	<p>Optional for models shown.  Optional for DG5V-7-*B(L)/C/D models, but horizontal  mounting is recommended for DG5V-7-*A(L)/N models.</p>
<p>After-sales service:  Spare-parts data for DG3 valves and main stages of DG5  valves, and pilot choke modules  Spare-parts data for DG4V-3S pilot stages of DG5 models</p>	<p>Consult your local Vickers representative.  Ask for spares leaflet I-3886-S (minimal text, in English).</p>

### Pilot Pressures

Maximum: 350 bar (5000 psi).

Typical minimum differential pilot pressure characteristics, shown below, are based on looped flow through P to A to B to T under standard test conditions.

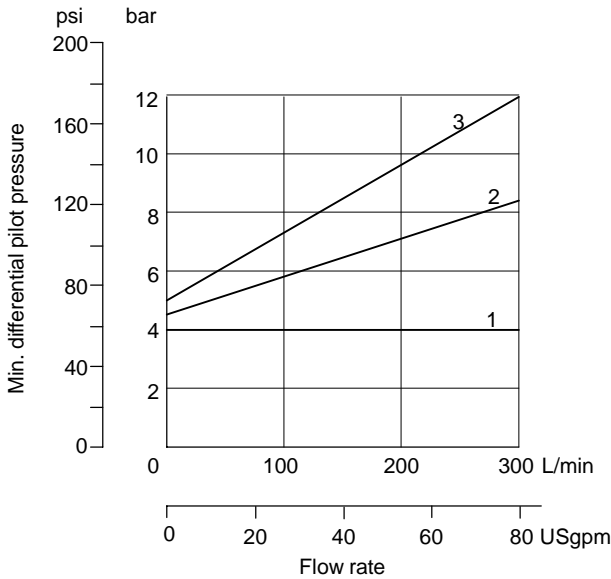

Spool types	0	1	2	3	4	6	8	9	11	31	33	52	X*	Y*
Curve ref.	1	1	3	3	1	2	1	1	1	3	3	3	3	3

Applicable to:

Model	Spool type	Curve correction
DG3V-7-*C	All	As drawn
DG3V-7-*D	All	Add 5 bar (73 psi)
DG5V-7-*A(L)	0, 2, 6, 9, 52, X2 and Y2	Subtract 3 bar (44 psi)
DG5V-7-*B(L)	0, 2, 6, 52▲, X2 and Y2	As drawn
DG5V-7-*C	All	As drawn
DG5V-7-*D	All	Add 5 bar (73 psi)
DG5V-7-*N	0, 2, 6, 9, 52, X2 and Y2	As drawn

▲ DG5V-7-52BL models only.

### Pressure Drop Characteristics

The following typical pressure drops ( $\Delta p$ ) at flow rates ( $Q$ ) are based on standard test conditions, using oil of 0.865 specific gravity. Except where otherwise stated, for any other flow rate ( $Q_1$ ) the pressure drop ( $\Delta p_1$ ) will be approximately  $\Delta p_1 = \Delta p (Q_1 / Q)^2$ .

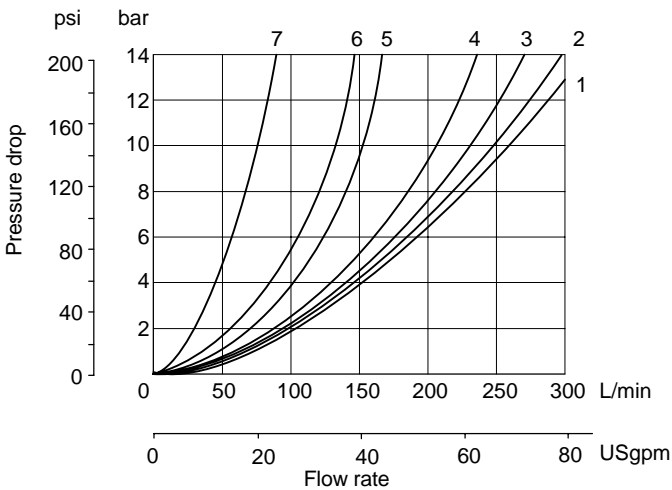

Spool type	Flow-direction curve ref.				
	P→A	B→T	P→B	A→T	P→T
0	2	1	2	3	3■
1	1	2	2	3	4▼
2	1	2	1	2	—
3	1	2	1	3	—
4	2	2	2	1	6
6	1	1	1	3	—
8	2	2	2	1	5
9	1	2	1	3	7
11	2	3	1	2	4
31	1	3	1	2	—
33	1	2	1	2	—
52▲	2●	—	3▼	—	—
52◆	—	—	3	3	—

■ Ports A and B plugged. ▼ Port A plugged.  
▲ Selected P to A. ● Port B plugged. ◆ Selected P to B.

---

**Minimum-Pilot-Pressure Generator**

For valves fitted with this option, the P to A or B pressure drop derived from the graph on the previous page is increased by 3,5 bar (51 psi) at 50 L/min (13 USgpm).

At any other flow rate  $Q_1$  the total pressure drop becomes:

- a. For pressures in bar and flow rates in L/min:

$$\Delta p_1 = 3,5 \left( \frac{Q_1}{50} \right)^2$$

- b. For pressures in psi and flow rates in USgpm:

$$\Delta p_1 = 51 \left( \frac{Q_1}{13.2} \right)^2$$

**Hydraulic Fluids**

Materials and seals used in these valves are compatible with antiwear hydraulic oils, water-glycols, water-in-oil emulsions and non-alkyl-based phosphate esters. The extreme operating range is 500 to 13 cSt (2270 to 70 SUS) but the recommended running range is 54 to 13 cSt (245 to 70 SUS). For further technical information about fluids see "Technical Information" leaflet B-920 or I-286S.

**Contamination Control Requirements**

Recommendations on contamination control methods and the selection of products to control fluid condition are included in Vickers publication 9132 or 561, "Vickers Guide to Systemic Contamination Control". The book also includes information on the Vickers concept of "ProActive Maintenance". The following recommendations are based on ISO cleanliness levels at 2  $\mu\text{m}$ , 5  $\mu\text{m}$  and 15  $\mu\text{m}$ . For products in this catalog the recommended levels are:

Up to 210 bar (3000 psi) . . . . . 20/18/15

Above 210 bar (3000 psi) . . . . . 19/17/14

**Fluid Temperatures**

For petroleum oil:

Min. . . . .  $-20^\circ\text{C}$  ( $-4^\circ\text{F}$ )

Max.\* . . . . .  $+70^\circ\text{C}$  ( $+158^\circ\text{F}$ )

\* *To obtain optimum service life from both fluid and hydraulic system,  $65^\circ\text{C}$  ( $150^\circ\text{F}$ ) normally is the maximum temperature.*

For other fluids where limits are outside those of petroleum oil, consult fluid manufacturer or Vickers representative. Whatever the actual temperature range, ensure that viscosities stay within those specified under "Hydraulic Fluids".

# Installation Dimensions in mm (inches)

## Solenoid Controlled Models with ISO 4400 (DIN 43650)

### Electrical Connections and Pilot Choke

DG5V-7-\*\*(L)(-2)(-E)(-T)(-K)(-\*)-(V)M-U example

For dimensions A, B, C, D and E see page A.15.

For solenoid identification see page A.15.

For stroke adjusters see page A.14.

3rd angle projection

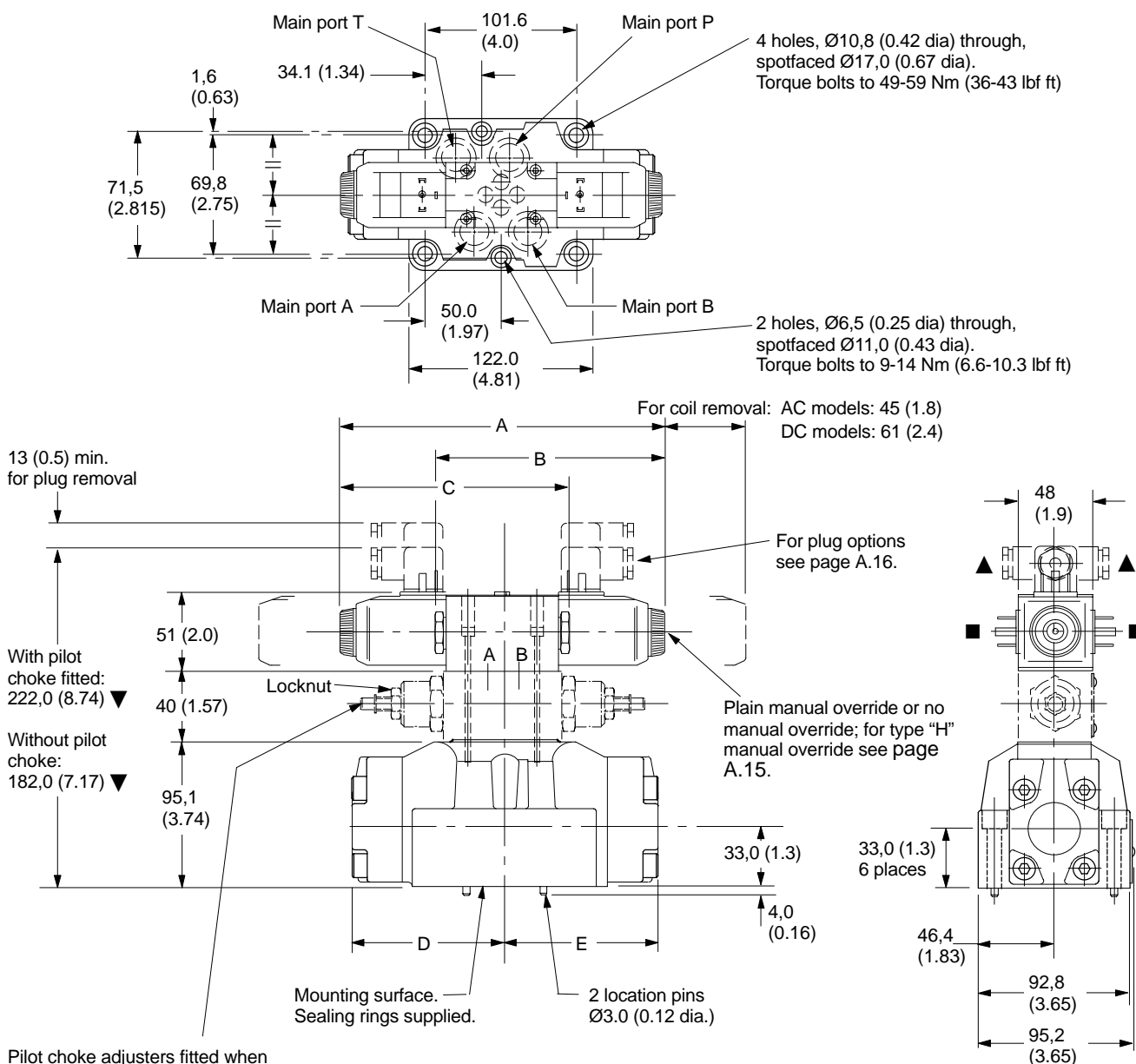
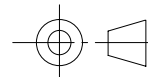

Pilot choke adjusters fitted when Model Code **4** = 2, 3, 27 or 28.  
To adjust, turn locknut counter-clockwise, then turn screw clockwise to slow down rate of spool travel, or counter-clockwise to increase the rate. Retighten locknut to 25-30 Nm (18-22 lbf ft).

- ▼ May vary according to plug source.
- Alternative plug positions by loosening knurled nut counter-clockwise, turning coil and re-tightening nut.

- ▲ Cable entry can be positioned at 90° either way from position shown, by re-assembling the contact holder into the appropriate position inside the plug connector housing.

**Solenoid Controlled Models with Stroke Adjusters**

DG5V-7-\*\*\*(L)(-2)(-E)(-T)(-K)(-\*)-(V)M-U example

For solenoid identification see page A.15.

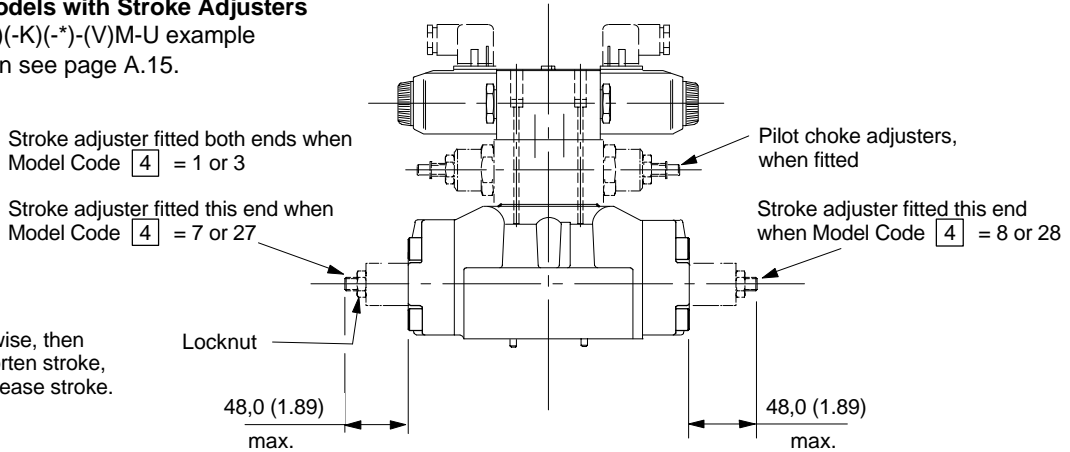

To adjust:  
Turn locknut counter-clockwise, then turn screw clockwise to shorten stroke, or counter-clockwise to increase stroke. Re-tighten locknut.

**Solenoid Controlled Models with Junction Box having Optional Terminal Strip and Indicator Lights**

DG5V-7-\*\*\*(L)(-\*)(-E)(-T)(-K)(-\*)-(V)MF\*\*(L) example.

For solenoid identification see page A.15.

Available also with other options shown above and on previous page.

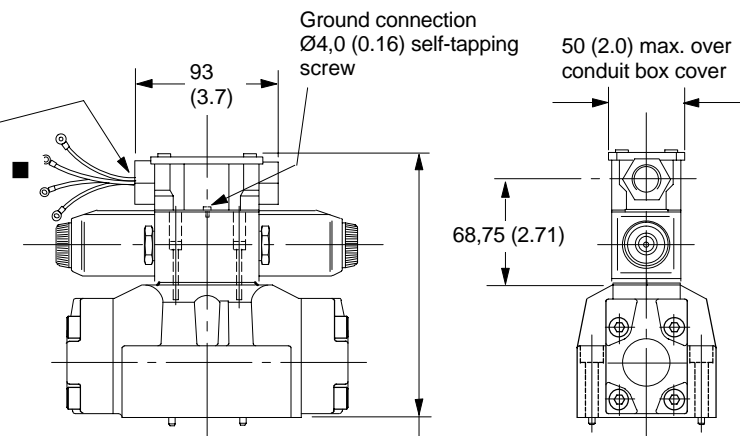

M20-6H x 1,5 thread for F(T)J options, or 1/2" NPT for F(T)W options, at both ends. Closure plug fitted at one end.

For other options see [10] & [11] in "Model Code", eight pages back, and under "NFPA Connector---" and "Terminal Strip and Lights" sections, two pages on.

With pilot choke fitted: 227,0 (8.94)  
Without pilot choke: 187,0 (7.36)

- Ref. "Model Code" [10]:  
Codes "FJ" and "FW": 2 lead wires for each solenoid, approx. 150 (6.0) long. M3 (#6) terminals provided for customer connection.  
Codes "FTJ" and "FTW": Valve supplied with lead wires connected into terminal strip suitable for M3 (#6) terminals provided for customer connection.

**Pilot Operated Models with Optional Pilot Choke and/or Stroke Adjusters**

DG3V-7-\*\*-2)(-\*\*) example

For dimensions D and E see page A.15.

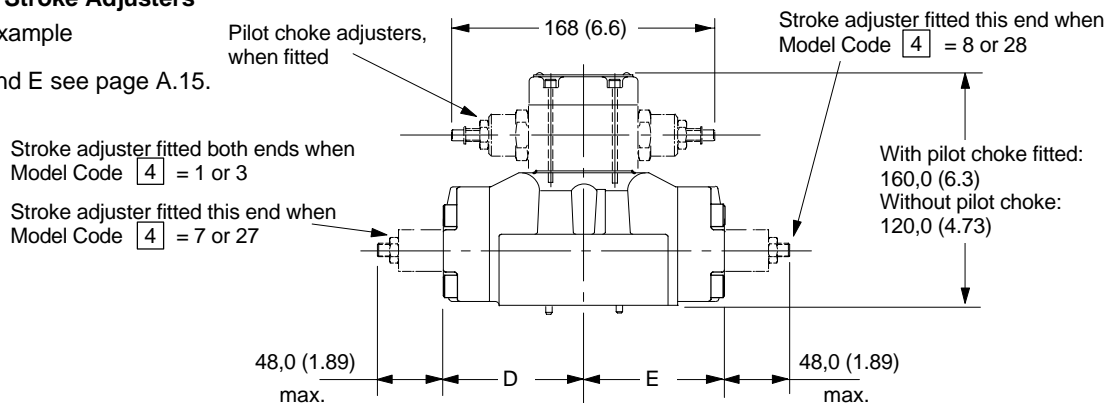

### Solenoid Identification

Model (see also 10 in "Model Code" on page A.6)	Spool types	Solenoid identity at:	
		Main port "A" end	Main port "B" end
DG5V-7-*A/B(-**)(-E)(-T)(-K)(-*)-M	All except "4" & "8"	–	B
DG5V-7-*A/B(-**)(-E)(-T)(-K)(-*)-VM	All except "4" & "8" "4" & "8" only	– B	A –
DG5V-7-*AL/BL(-**)(-E)(-T)(-K)(-*)-M	All except "4" & "8"	A	–
DG5V-7-*AL/BL(-**)(-E)(-T)(-K)(-*)-VM	All except "4" & "8" "4" & "8" only	B –	– A
DG5V-7-*C/D/N(-**)(-E)(-T)(-K)(-*)-M	All except "4" & "8"	A	B
DG5V-7-*C/D/N(-**)(-E)(-T)(-K)(-*)-VM	All spools	B	A

### Dimensions

Basic model designation	AC models			DC models				
	A	B	C	A	B	C	D	E
DG3V-7-*C	–	–	–	–	–	–	97,0 (3.82)	97,0 (3.82)
DG3V-7-*A ■	–	–	–	–	–	–	97,0 (3.82)	131,0 (5.16)
DG3V-7-*A(L) ■	–	–	–	–	–	–	131,0 (5.16)	97,0 (3.82)
DG3V-7-*D	–	–	–	–	–	–	131,0 (5.16)	97,0 (3.82)
DG5V-7-*A ■	–	–	–	–	–	–	97,0 (3.82)	97,0 (3.82)
DG5V-7-*B ■	–	147 (5.8)	–	–	157 (6.2)	–	97,0 (3.82)	97,0 (3.82)
DG5V-7-4/8BL	–	–	–	–	–	–	97,0 (3.82)	97,0 (3.82)
DG5V-7-*AL ■	–	–	–	–	–	–	97,0 (3.82)	97,0 (3.82)
DG5V-7-*BL ■	–	–	147 (5.8)	–	–	157 (6.2)	97,0 (3.82)	97,0 (3.82)
DG5V-7-4/8B	–	–	–	–	–	–	97,0 (3.82)	97,0 (3.82)
DG5V-7-*C	200 (7.8)	–	–	220 (8.7)	–	–	97,0 (3.82)	97,0 (3.82)
DG5V-7-*N	200 (7.8)	–	–	220 (8.7)	–	–	97,0 (3.82)	97,0 (3.82)
DG5V-7-*D	200 (7.8)	–	–	220 (8.7)	–	–	131,0 (5.16)	97,0 (3.82)

■ Not types "4" or "8" spools.

### Water-Resistant Manual Override on Solenoids

DG5V-7---M-\*\*\*\*(L)H valves

#### Application:

General use where finger operation is required (standard manual overrides can only be operated by using a small tool).

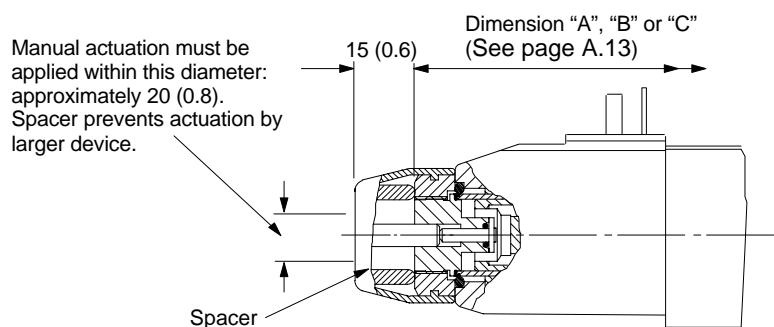

Note: "H" feature is not field convertible from other models; specify with order.

# Electrical Plugs and Connectors

## Plugs for ISO 4400 (DIN 43650) Type Coil Connection

For valves with type "U" coils

The cable entry on these plugs can be repositioned at 90° intervals by reassembly of the contact holder relative to the plug housing.

The cable entry is Pg.11, for cable Ø 6-10 mm (0.24 to 0.39" dia).

Order separately by part number.

Plugs without indicator lights

Part no.	Color	Use on solenoid coil
710775	Black	Sol. B
710776	Gray	Sol. A

Plugs with indicator lights

Voltage	Part no.	
	Gray (sol. A)	Black (sol. B)
12-24V	977467	977466
100-125V	977469	977468
200-240V	977471	977470

## NFPA Connector T3.5.29-1980

DG5V-7-\*\*\*---FPA3W(L) and DG5V-7-\*\*\*---FPA5W(L) models

The receptacle is a standard three or five-pole connector with shortened leads and terminals added. The five-pole plug has four leads 101,6 mm (4.0") long and one of 177,8 mm (7.0") length. All wires have US Underwriters Laboratory-recognized non-solder insulated eyelet terminals. The green wire is used for the ground (earth) connection (No. 8-size screw furnished). Valves are supplied prewired.

Connection details and model type/model code references

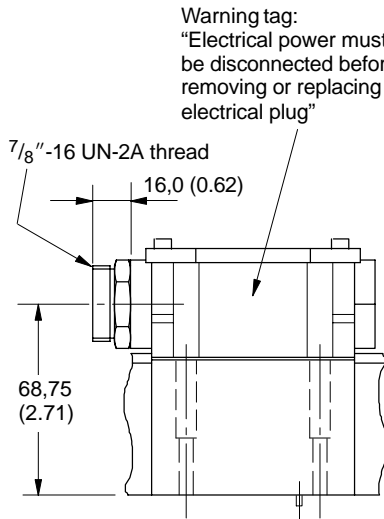

5-pin connector

When fitted in double-solenoid valves, e.g.:

DG5V-7-\*C(-\*\*-)(V)M-FPA5W(L)  
 DG5V-7-\*D(-\*\*-)(V)M-FPA5W(L)  
 DG5V-7-\*N(-\*\*-)(V)M-FPA5W(L)

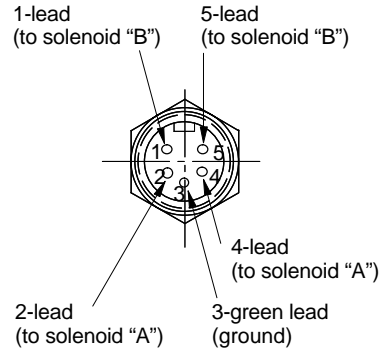

3-pin connector

When fitted in single-solenoid valves, e.g.:

DG5V-7-\*A(L)(-\*\*-)(V)M-FPA3W(L)  
 DG5V-7-\*B(L)(-\*\*-)(V)M-FPA3W(L)

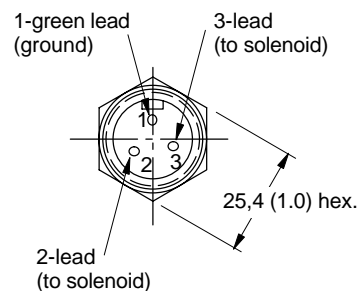

5-pin connector

When fitted in single-solenoid valves, e.g.:

DG5V-7-\*A(L)(-\*\*-)(V)M-FPA5W(L)  
 DG5V-7-\*B(L)(-\*\*-)(V)M-FPA5W(L)

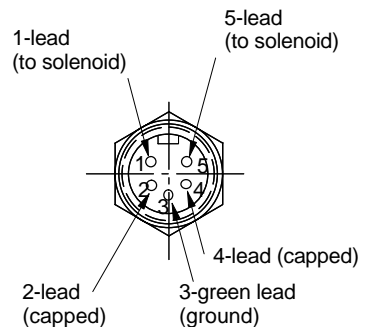



## Terminal Strip and Light Options

When fitted in solenoid controlled valves DG5V-7-\*\*(L)---F\*\*\*\*(L).

DG5V-7-\*\*(L)---F\*\*\*\*-\*

DG5V-7-\*\*(L)---F\*\*\*\*L-\*

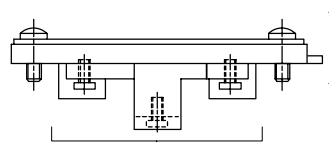

Terminal strip (part number 890345) clips to cover and can be field-fitted

Conduit box cover and nameplate complete with sealing gasket and 4 screws

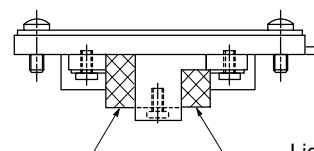

Lights

M3 x 0,5-6H screws (part number 186006) 2 each end  
4 terminal screws M3 x 0,5-6H (part number 02-113355)

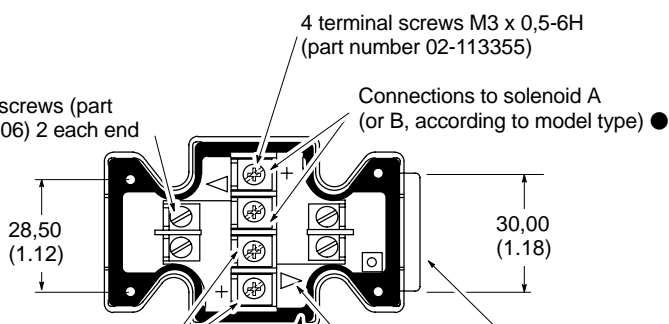

M3 x 0,5-6H screws (part number 186006) 2 each end

Connections to solenoid A (or B, according to model type) ●

28,50 (1.12)  
30,00 (1.18)

Connections to solenoid B (or A, according to model type) ●

Anti-rotation tab ensures correct orientation of cover to junction box

Rubber gasket  
2 lenses in cover

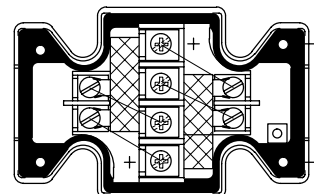

● 1. For DC coils the +ve lead(s) must be connected to the terminal(s) marked +. When using 3-wire incoming leads to double solenoid valves (i.e. common neutral) the inner pair of terminals must be linked.

2. For correct light indication of energized solenoid ensure that solenoid leads are correctly connected: light terminals are common with each outer pair of solenoid terminals according to the side with + mark.

Алматы (7273)495-231  
Ангарск (3955)60-70-56  
Архангельск (8182)63-90-72  
Астрахань (8512)99-46-04  
Барнаул (3852)73-04-60  
Белгород (4722)40-23-64  
Благовещенск (4162)22-76-07  
Брянск (4832)59-03-52  
Владивосток (423)249-28-31  
Владикавказ (8672)28-90-48  
Владимир (4922)49-43-18  
Волгоград (844)278-03-48  
Вологда (8172)26-41-59  
Воронеж (473)204-51-73  
Екатеринбург (343)384-55-89

Иваново (4932)77-34-06  
Ижевск (3412)26-03-58  
Иркутск (395)279-98-46  
Казань (843)206-01-48  
Калининград (4012)72-03-81  
Калуга (4842)92-23-67  
Кемерово (3842)65-04-62  
Киров (8332)68-02-04  
Коломна (4966)23-41-49  
Кострома (4942)77-07-48  
Краснодар (861)203-40-90  
Красноярск (391)204-63-61  
Курск (4712)77-13-04  
Курган (3522)50-90-47  
Липецк (4742)52-20-81

Магнитогорск (3519)55-03-13  
Москва (495)268-04-70  
Мурманск (8152)59-64-93  
Набережные Челны (8552)20-53-41  
Нижний Новгород (831)429-08-12  
Новокузнецк (3843)20-46-81  
Ноябрьск (3496)41-32-12  
Новосибирск (383)227-86-73  
Омск (3812)21-46-40  
Орел (4862)44-53-42  
Оренбург (3532)37-68-04  
Пенза (8412)22-31-16  
Петрозаводск (8142)55-98-37  
Псков (8112)59-10-37  
Пермь (342)205-81-47

Ростов-на-Дону (863)308-18-15  
Рязань (4912)46-61-64  
Самара (846)206-03-16  
Санкт-Петербург (812)309-46-40  
Саратов (845)249-38-78  
Севастополь (8692)22-31-93  
Саранск (8342)22-96-24  
Симферополь (3652)67-13-56  
Смоленск (4812)29-41-54  
Сочи (862)225-72-31  
Ставрополь (8652)20-65-13  
Сургут (3462)77-98-35  
Сыктывкар (8212)25-95-17  
Тамбов (4752)50-40-97  
Тверь (4822)63-31-35

Тольятти (8482)63-91-07  
Томск (3822)98-41-53  
Тула (4872)33-79-87  
Тюмень (3452)66-21-18  
Ульяновск (8422)24-23-59  
Улан-Удэ (3012)59-97-51  
Уфа (347)229-48-12  
Хабаровск (4212)92-98-04  
Чебоксары (8352)28-53-07  
Челябинск (351)202-03-61  
Череповец (8202)49-02-64  
Чита (3022)38-34-83  
Якутск (4112)23-90-97  
Ярославль (4852)69-52-93

Россия +7(495)268-04-70

Казахстан +7(7172)727-132

Киргизия +996(312)96-26-47