

Алматы (7273)495-231
Ангарск (3955)60-70-56
Архангельск (8182)63-90-72
Астрахань (8512)99-46-04
Барнаул (3852)73-04-60
Белгород (4722)40-23-64
Благовещенск (4162)22-76-07
Брянск (4832)59-03-52
Владивосток (423)249-28-31
Владикавказ (8672)28-90-48
Владимир (4922)49-43-18
Волгоград (844)278-03-48
Вологда (8172)26-41-59
Воронеж (473)204-51-73
Екатеринбург (343)384-55-89

Иваново (4932)77-34-06
Ижевск (3412)26-03-58
Иркутск (395)279-98-46
Казань (843)206-01-48
Калининград (4012)72-03-81
Калуга (4842)92-23-67
Кемерово (3842)65-04-62
Киров (8332)68-02-04
Коломна (4966)23-41-49
Кострома (4942)77-07-48
Краснодар (861)203-40-90
Красноярск (391)204-63-61
Курск (4712)77-13-04
Курган (3522)50-90-47
Липецк (4742)52-20-81

Магнитогорск (3519)55-03-13
Москва (495)268-04-70
Мурманск (8152)59-64-93
Набережные Челны (8552)20-53-41
Нижний Новгород (831)429-08-12
Новокузнецк (3843)20-46-81
Ноябрьск (3496)41-32-12
Новосибирск (383)227-86-73
Омск (3812)21-46-40
Орел (4862)44-53-42
Оренбург (3532)37-68-04
Пенза (8412)22-31-16
Петрозаводск (8142)55-98-37
Псков (8112)59-10-37
Пермь (342)205-81-47

Ростов-на-Дону (863)308-18-15
Рязань (4912)46-61-64
Самара (846)206-03-16
Санкт-Петербург (812)309-46-40
Саратов (845)249-38-78
Севастополь (8692)22-31-93
Саранск (8342)22-96-24
Симферополь (3652)67-13-56
Смоленск (4812)29-41-54
Сочи (862)225-72-31
Ставрополь (8652)20-65-13
Сургут (3462)77-98-35
Сыктывкар (8212)25-95-17
Тамбов (4752)50-40-97
Тверь (4822)63-31-35

Тольятти (8482)63-91-07
Томск (3822)98-41-53
Тула (4872)33-79-87
Тюмень (3452)66-21-18
Ульяновск (8422)24-23-59
Улан-Удэ (3012)59-97-51
Уфа (347)229-48-12
Хабаровск (4212)92-98-04
Чебоксары (8352)28-53-07
Челябинск (351)202-03-61
Череповец (8202)49-02-64
Чита (3022)38-34-83
Якутск (4112)23-90-97
Ярославль (4852)69-52-93

Россия +7(495)268-04-70

Казахстан +7(7172)727-132

Киргизия +996(312)96-26-47

<https://vickers.nt-rt.ru> || vsh@nt-rt.ru

DG5S-8 and DG5S-H8

Two-Stage, Solenoid Controlled,
Pilot Operated, Four-Way Directional Valves

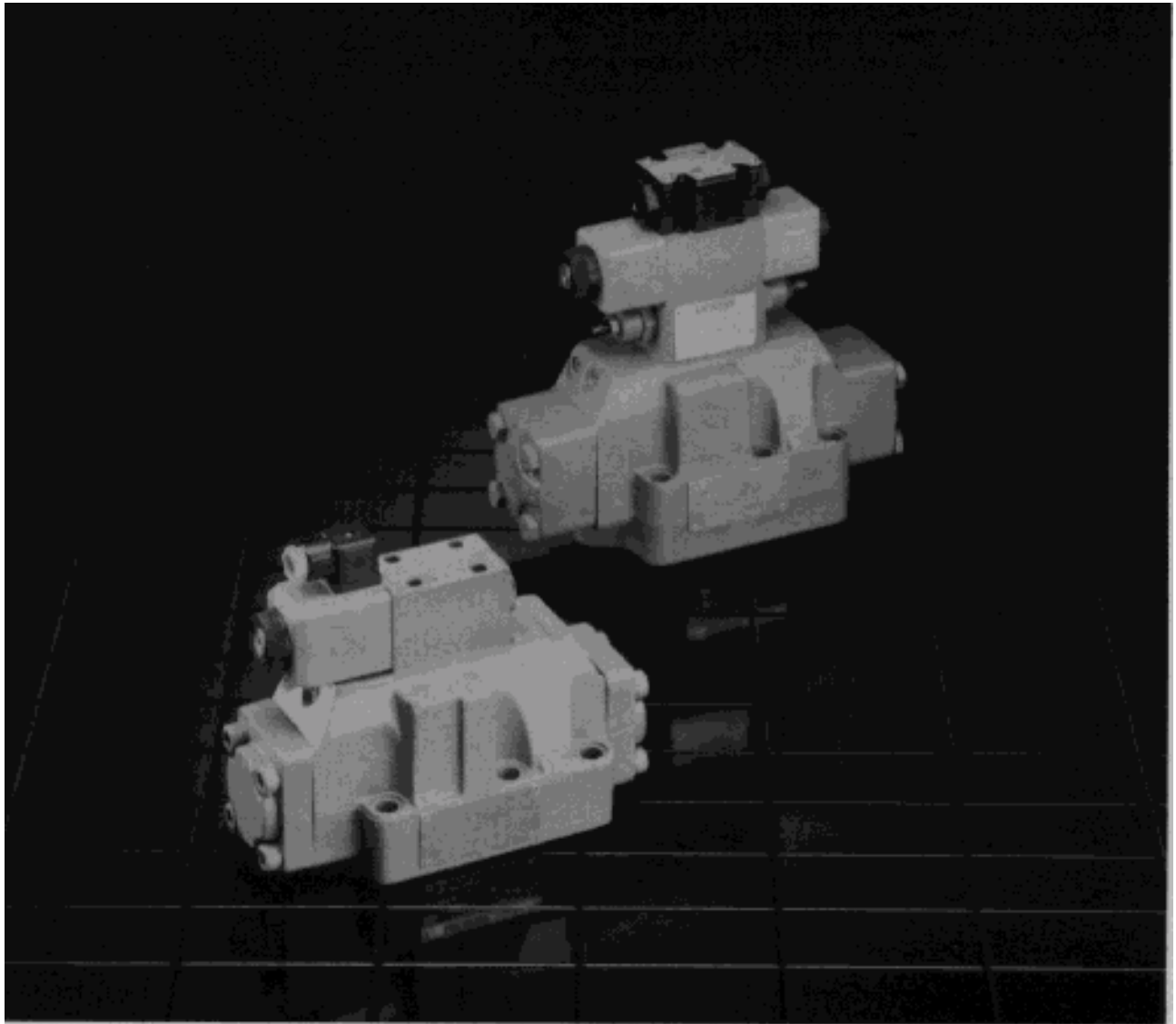

Introduction

General Description

The DG5S-8 and DG5S-H8 are two-stage directional valves with an integrally mounted DG4V3(S) (wet armature solenoid) pilot valve.

These valves are used to control the direction of flow in hydraulic circuits. This directional control in turn provides control over the movement of a cylinder or the rotation of a hydraulic motor.

Features and Benefits

- Suitable for the most demanding industrial applications with DG5S-H8 flow capacities up to 530 L/min (140 USgpm) and rated pressure of 310 bar (4500 psi).
- Available with a wide variety of spool and spring arrangements, stroke and pilot choke adjustments, integral check valves, and port orifices.
- Uses Vickers DG4V3(S) pilot valve for exceptional responsiveness, durability, and ease of servicing.
- Numerous electrical options allow full compatibility and easy, reliable connection in any system application.
- Fast response and standard low shock models available.
- Solid cast body and core passages for maximum strength and minimal pressure drop.
- High-force solenoids and centering springs assure consistent shifting through a wide range of pressure and silting extremes.
- Designed and backed by Vickers, with over 70 years as the global leader in fluid power and motion control.

Cross Section of Typical Valve (DG5S-8-6B-T-M-U-H5-30)

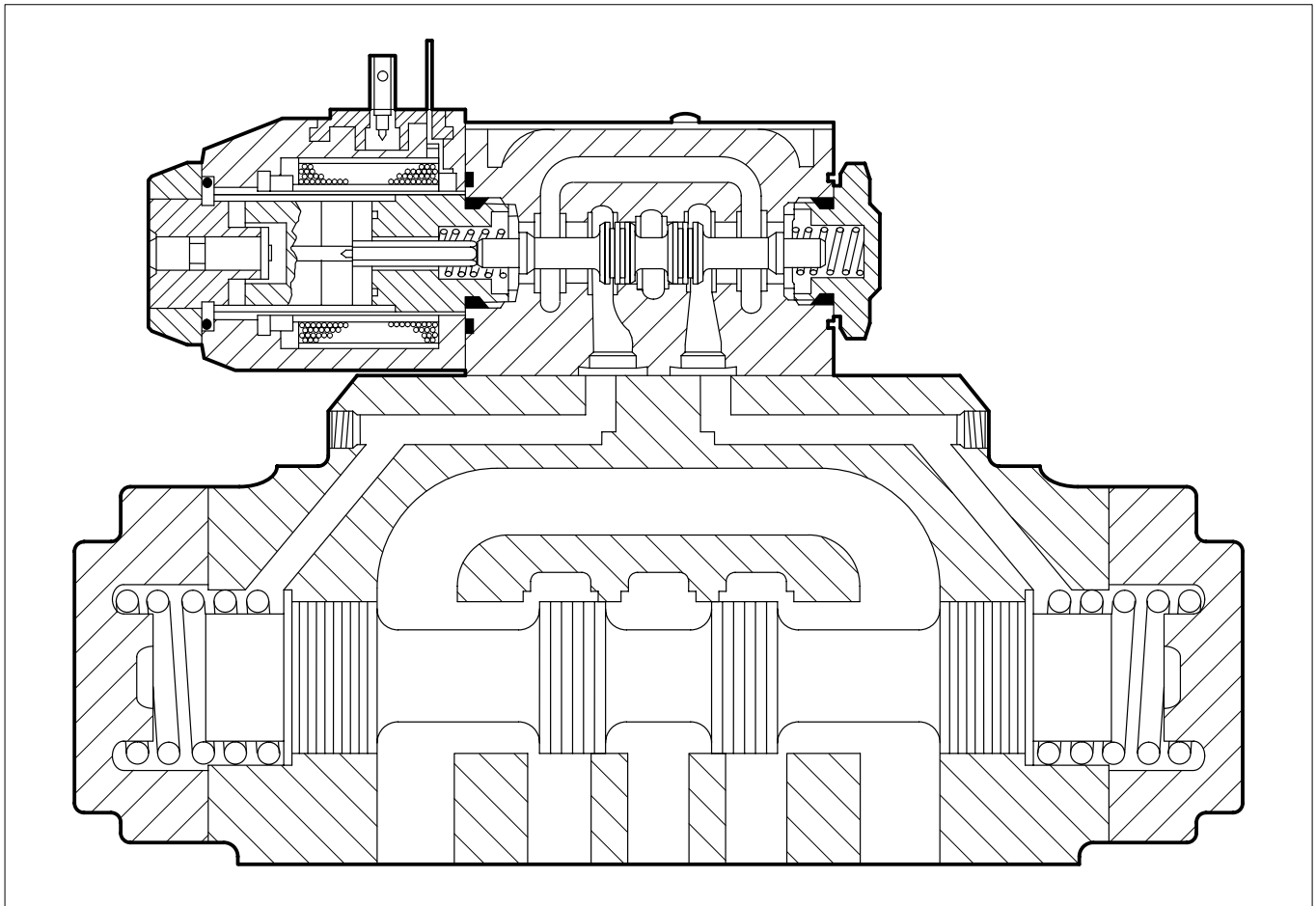

Table of Contents

Model Series	Recommended Flow	Maximum Operating Pressure	Page
DG5S-8	To 170 L/min (45 USgpm)	210 bar (3000 psi)	4
DG5S-H8 (High Flow)	To 265 L/min (70 USgpm)	310 bar (4500 psi)	6
	Accessories and Weights		22
	Installation and Application Data		24

DG5S-8 Model Series

Ratings

Recommended Flow* L/min (USgpm)	Maximum Operating Pressure (Ports P, A, & B) bar (psi)	Maximum Pilot Pressure bar (psi)	Maximum Tank Line Pressure bar (psi)		Mounting Pattern
			External Drain Models	Internal Drain Models	
To 170 (45)	210 (3000)	210 (3000)	210 (3000)	210 (3000)	ISO 4401-08, NFPA D08 (formerly D06), and ANSI B93.7

Maximum flow table see page 8

Model Codes

F3-DG5S-8-(L)(*) (X)-(*)-(E)-(T)(*)-(V)M-(S*) * (**)** (L)-** 5- ***-30/40-(EN470)**

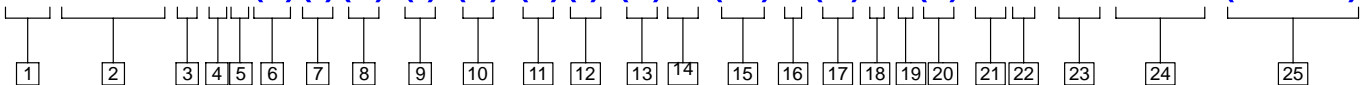

1 Viton seals

F3 – For mineral oil & fire resistant fluids
Blank – Omit if not required

2 Series designation

D – Directional control valve
G – Manifold or subplate mounted
5 – Solenoid controlled, pilot operated
S – Sliding spool, rated pressure 210 bar (3000 psi)

3 Interface

8 – NFPA D08 (ISO 4401-08)

4 Spool type

Code Center position
0 – Open to T all ports
1 – Open P & A to T, closed B
2 – Closed to T all ports
3 – Closed P & B, open A to T
**4 – Tandem P to T, closed crossover
6 – Closed P only, open A & B to T
7 – Open P to A & B, closed T
**8 – Tandem P to T, open crossover
9 – Open to T all ports over tapers
11 – Open P & B to T, closed A
31 – Closed P & A, open B to T
33 – Closed P, open A & B to T over tapers
52 – Closed center all ports

5 Spool/Spring arrangement

A – Spring offset to A port
B – Spring centered, solenoid A removed
C – Spring centered
D – Pressure centered
F – Spring offset to A port, shift to center
N – No spring detented (pilot only)

6 Left hand assembly

L – Left hand, single solenoid only. Omit if not required. (For right hand assembly, P to A port when solenoid A is energized.)
Blank – Omit if not required

7 Manual override

Blank – Plain override solenoid ends only
H – Waterproof override solenoid ends only
H2 – Waterproof override both ends of single solenoid
P2 – Plain override both ends of single solenoid
Y – Lockable manual overrides solenoid ends only/DC only
Z – No overrides in either end

8 Response type

X – Fast response
Blank – Standard low shock models

9 Spool control modifications

1 – Stroke adjustment both ends
2 – Pilot choke (dual) adjustment
3 – Pilot choke and stroke adjustment
7 – Stroke adjustment A port end only
8 – Stroke adjustment B port end only
2-7 – Dual pilot choke and stroke adjustment A port end only
2-8 – Dual pilot choke and stroke adjustment B port end only
Blank – Omit if not required

10 Pilot pressure

E – External pilot pressure
Blank – Internal pilot pressure

11 Pilot drain

T – Internal pilot drain
Blank – External pilot drain

12 Pressure port check valve

K – 0,35 bar (5 psi) cracking pressure
R – 3,45 bar (50 psi) cracking pressure
S – 5,20 bar (75 psi) cracking pressure
Blank – Omit if not required

** Type 4 and 8 spools may spin within the body causing unusual valve body wear. With this and other spool types, valve malfunction may occur. Where these applications exist use the DG5S-8*-30/40 EN470 special designator for 4C/8C anti-spin spools/springs.

Model Codes (continued)

13 Solenoid energization identity

V – Solenoid identification determined by position of solenoid (solenoid A at port A end and/or solenoid B at port B end)

Blank – Standard arrangement for ANSI B93.9 (energize solenoid A for flow P to A port)

(Code V for any valve with code 4 or code 8 spool)

14 Flag symbol

M – Electrical options and features

15 Spool indicator switch

(Available on models with high performance pilot DG4V3 only)

S3 – Normally open (available on valves with code P* only)

S4 – Normally closed (available on valves with code P* only)

S5 – Free leads (available on valves with coil type code F only)

S6 – LVDT type DC switch with Pg7 connector plug

16 Coil type

U – ISO 4400

F – Flying lead

SP1 – Single 6,3 mm spade to IEC 760

SP2 – Dual 6,3 mm spade to IEC 760

17 Electrical connections

(Code F coil only)

T – Wired terminal block

PA – Instaplug male receptacle only

PB – Instaplug male & female receptacle

PA3 – Three pin connector

PA5 – Five pin connector

Blank – Omit if not required

18 Housing

(Code F coil only)

W – 1/2 NPT thread wiring housing

J – 20 mm thread wiring housing

Blank – Omit if not required

19 Electrical options

(Code U coil only)

1 – ISO with fitted plug

6 – ISO with fitted plug and lights

20 Solenoid indicator lights

(Code F coil with code T electrical connections only)

L – Indicator lights

Blank – Omit if not required

21 Coil identification

A – 110V AC 50 Hz

B – 110V AC 50 Hz/120V AC 60 Hz*

C – 220V AC 50 Hz

D – 220V AC 50 Hz/240V AC 60 Hz*

G – 12 VDC

H – 24 VDC

DJ – 98 VDC

P – 110 VDC

* For 60 Hz or dual frequency

22 Pilot valve tank pressure rating

2 – 10 bar (145 psi) DG4V3-60 with S3, S4, or S5 spool indicator switch

5 – 100 bar (1450 psi) DG4V3S-60

6 – 210 bar (3000 psi) DG4V3-60 with AC solenoids and optional S6 spool indicator switch

7 – 210 bar (3000 psi) DG4V3-60 with DC solenoids and optional S6 spool indicator switch

23 Pilot valve port orifices

Code Orifice diameter

*00 – Solid plug

*03 – 0,30 mm (0.012 in)

*06 – 0,60 mm (0.024 in)

*08 – 0,80 mm (0.030 in)

*10 – 1,00 mm (0.040 in)

*13 – 1,30 mm (0.050 in)

*15 – 1,50 mm (0.060 in)

*20 – 2,00 mm (0.080 in)

*23 – 2,30 mm (0.090 in)

Blank – Omit if not required

(* = P, T, A, and/or B as required)

24 Design number

30 – DG4V3S-60 pilot valve

40 – DG4V3-60 pilot valve

(Subject to change. Installation dimensions same for designs 30 through 39 and 40 through 49.)

25 Special Feature

DG5S-8 Model Series

Performance Characteristics

Shift Time

Shift time is defined as the elapsed time from when the pilot valve solenoid is energized to the time the main stage spool shifts to its full stroke. Shift time curves are shown for standard low shock and fast response models at 210 bar (3000 psi) system pressure with various pilot pressures and spools. Pressure centering time curves are shown for pressure centered models. Approximate spring centering times are also listed for spring centered models.

Shifting Action

The pilot valve solenoids of spring centered, pressure centered, and spring offset models must be energized continuously to keep the main stage spool in the shifted position. No-spring detented models only need to be energized momentarily (for approximately 0.1 second).

Spring centered and pressure centered models return the valve spool to the center position when both solenoids are de-energized or pilot pressure fails or falls below minimum requirements. Spring offset models return the spool to the offset position by pilot pressure when the solenoid is de-energized.

When no-spring detented models are de-energized, the pilot and main spools remain in their last position as long as there are no unusual shock, vibration, or pressure transients, and the spool axis is horizontal. If pilot pressure fails or falls below the minimum, the main spool will spring center (at spring centered flow rates), but will not drift to a reversal of flow position. The pilot stage will remain in the detented position.

CAUTION

Be careful when setting up flow conditions for the spring centered position of the main stage spool in no-spring detented models. Be sure to consider the effect of the direction of the flow and the pilot pressure. The type 9 main spool may not ensure sufficient pilot pressure in the center position.

Shift Time For AC Models at Rated Flow and Pressure (Add approximately 25 milliseconds for DC models)

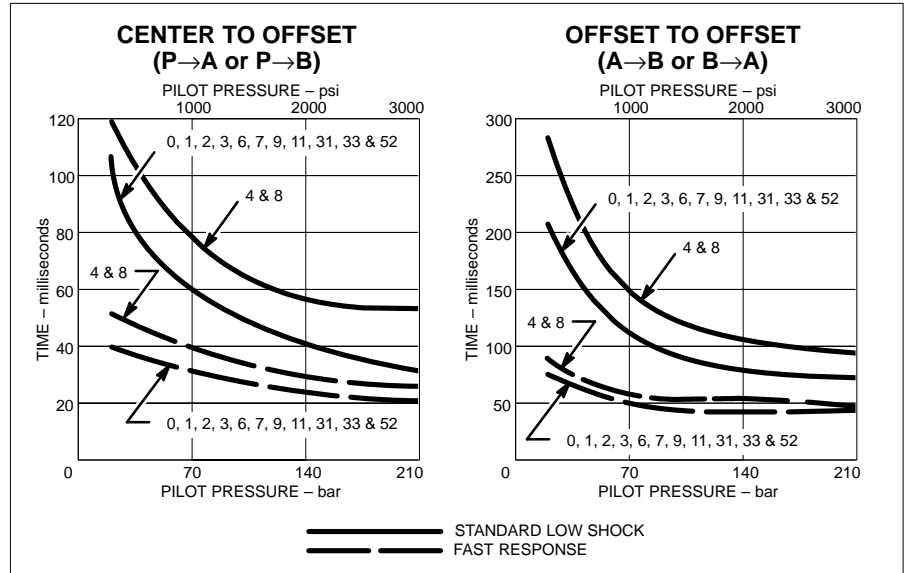

Spring Centering Times at Rated Flow and Pressure

Spool Types	AC Models	DC Models
2, 3, 6, 7, 31, 33, 52	.050 sec	.070 sec
0, 1, 11	.070 sec	.100 sec
4, 8	.090 sec	.120 sec
9	.135 sec	.160 sec

Fast Response

Valves with the fast response option have decreased shift time, but increased system shock generation. Fast response is available by adding the symbol "X" in the eighth position of the model code (example: DG5S-8-2CX-M-W*-20). The shift time and centering time curves show both standard and fast response times. Because of the high drain line pressure transients generated during shifting, use of the fast response option is not recommended for pilot pressures exceeding 140 bar (2000 psi).

Centering Times for Pressure Centered Valves at Rated Pressure (A to P or B to P)

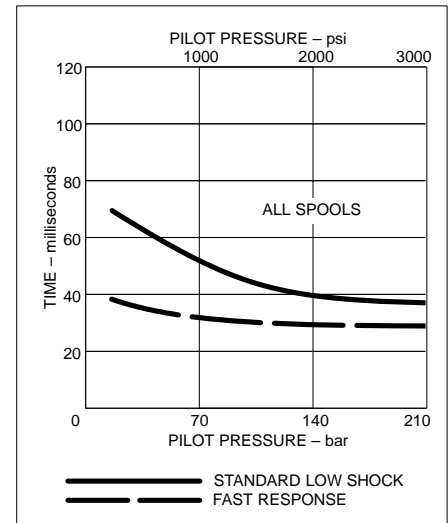

Spool Type and Center Position

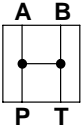
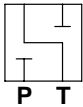
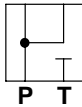
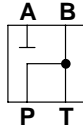
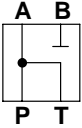
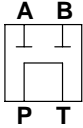
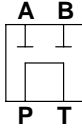
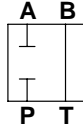
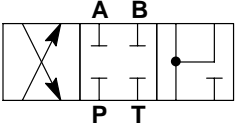
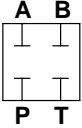
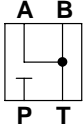
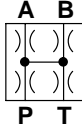
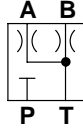
Spool Type	Center Position	Spool Type	Center Position	Spool Type	Center Position	Spool Type	Center Position	Spool Type	Center Position
0		3		7		11		52	(Below)
1		4	(Closed Crossover) 	8	(Open Crossover) 	31			
2		6		9		33			

Minimum Pilot Pressure Requirements

Spool-Spring Arrangement	Spool Type	Minimum Pilot Pressure bar (psi)	
		For Recommended Flow at System Pressure Up to 210 bar (3000 psi)	For Maximum Flow Without Malfunction at System Pressure of 210 bar (3000 psi)
Spring Centered Spring Offset No-Spring Detented	0, 1, 4, 7, 8, 9, and 11 (open center)	5 (75)	5 (75)
	2, 3, 6, 31, 33, and 52 (closed center)	8 (120)	10 (150)
Pressure Centered	0, 1, 4, 8, 9, and 11 (open center)	P to A: 5 (75) P to B: 10 (150)	P to A: 5 (75) P to B: 10 (150)
	2, 3, 6, 31, and 33 (closed center)	P to A: 8 (120) P to B: 16 (240)	P to A: 10 (150) P to B: 20 (300)

Application Guidance

The pilot pressure stated is based on internally piloted and externally drained models in which the pilot pressure is equal to pressure at the "P" port. With models having open center spools, pilot pressure can be assured by imposing a back pressure of at least the required minimum pilot pressure at the tank outlet connection (this back pressure will be present at cylinder ports if the spool type is 0, 1, 9, or 11), or by using an integral check valve that will not impose the additional pressure at the cylinder ports (see integral check valve note). Normally, internal pilot pressure for closed center spools is readily available. When pilot pressure from a separate source is required for either open or closed center spools, an external connection in the valve can be provided. (Add "E" to the model code.)

NOTE

Surges of oil in a common pilot valve drain line serving these and other valves can be of sufficient magnitude to cause inadvertent shifting of these valves. This is particularly critical in the no-spring detented type valves. Separate tank lines or a vented drain manifold with a continuous downward path to tank is necessary.

Any sliding spool, if held shifted under pressure for long periods of time, may stick and not spring return due to fluid residue formation (silting) and, therefore, should be cycled periodically to prevent this from happening.

When using as other than a normal four-way valve, consult your local Vickers representative.

Mounting Position

No-spring detented type valves must be installed with the longitudinal axis horizontal for good machine reliability. Mounting position of spring centered and spring offset valves is unrestricted provided that the pilot pressure is maintained as required. (Spring offset valves do not have a spring in the main spool section.)

DG5S-8 Model Series

Graphical Symbols

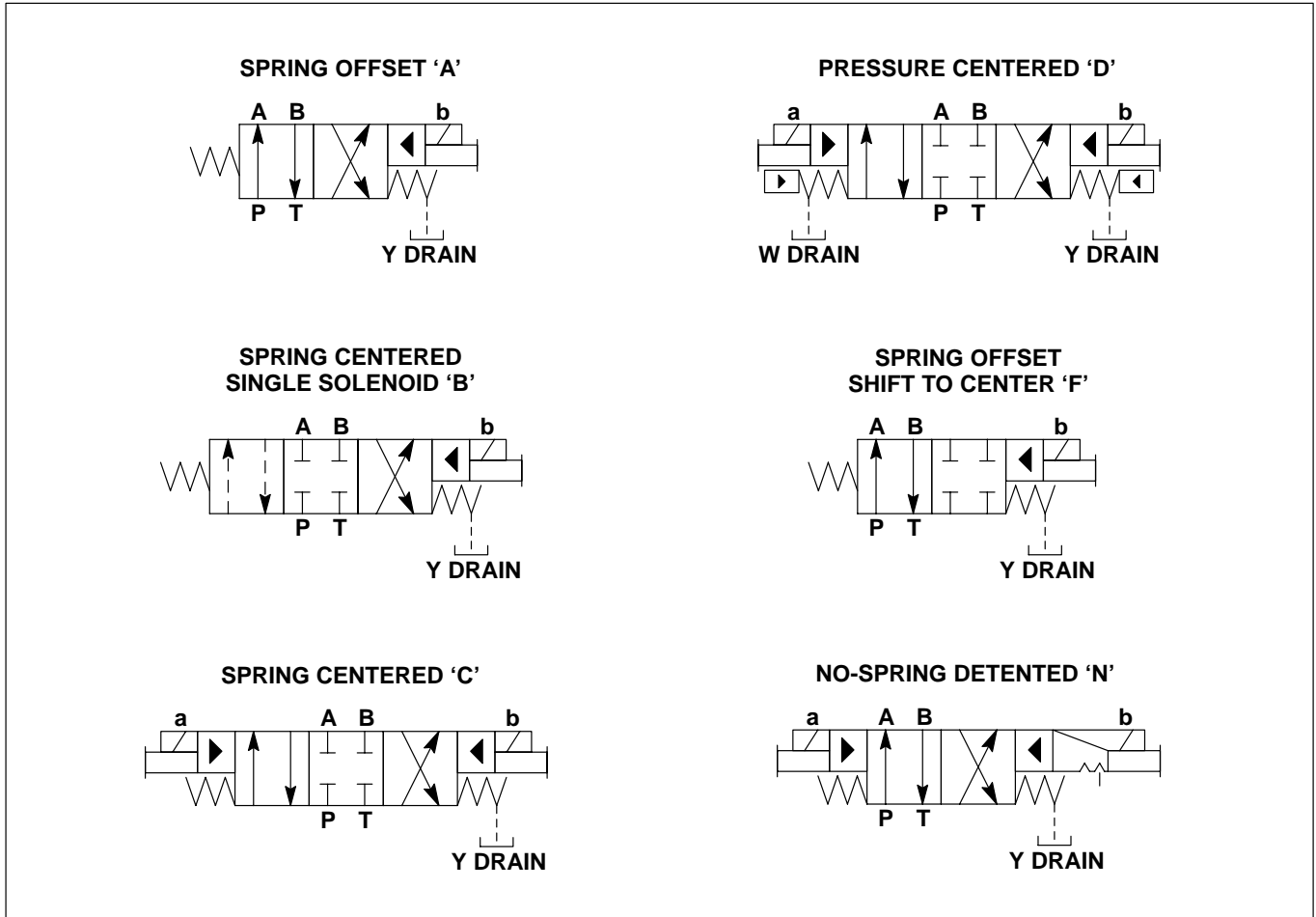

Flow Ratings

Valve Type	Spool Type	Recommended Flow Capacity at 210 bar (3000 psi) L/min (USgpm)	Maximum Flow Without Malfunction at:		
			70 bar (1000 psi) L/min (USgpm)	140 bar (2000 psi) L/min (USgpm)	210 bar (3000 psi) L/min (USgpm)
Spring Offset 'A'	0, 2, 6, 9, 33	170 (45)	380 (100)	380 (100)	380 (100)
Spring Centered	0, 2, 3, 6, 31, 33, 52*	170 (45)	380 (100)	380 (100)	380 (100)
Single Solenoid 'B'	1, 4, 7, 11	170 (45)	303 (80)	303 (80)	303 (80)
Spring Centered 'C'	8	170 (45)	303 (80)	303 (80)	303 (80)†
Spring Offset Shift to Center 'F'	9	133 (35)	190 (50)	133 (35)	133 (35)
Pressure Centered 'D'	0, 1, 2, 3, 4, 6, 7, 8, 9, 11, 31, 33	170 (45)	380 (100)	380 (100)	380 (100)
No-Spring Detented 'N'	0, 2, 6, 9, 33	170 (45)	380 (100)	380 (100)	380 (100)

† Fast valve switching of large oil volumes without adequate decompression circuitry can develop instantaneous flows well above maximum ratings. Type 4 and 8 spools may spin within body causing unusual valve body wear. With this and other spool types, valve malfunction may occur. Where these applications exist use the DG5S-8*-30/40 EN470 special feature designator for 4C/8C anti-spin spools/prings.

* Spool type 52 for Spring Centered 'C' type valves only.

Pressure Drop

The following table lists the appropriate pressure drop curve between ports for each spool type.

Spool Type	Pressure Drop Curve Number				
	P→A	B→T	P→B	A→T	P→T On Center
0	2	3	2	2	1
1	2	4	3	2	2
2	3	4	3	2	–
3	3	4	3	2	–
4	6	6	6	6	5
6	3	3	3	2	–
7	1	4	1	2	–
8	2	5	2	5	4
9	2	3	2	2	◆
11	3	3	2	2	2
31	3	3	3	2	–
33	3	4	3	2	–
52	3	■	3	2	–

■ Contact your Vickers representative.

◆ 13,8 bar (200 psi) at 95 L/min (25 USgpm) and 43,3 bar (700 psi) at 170 L/min (45 USgpm)

For example, to find the pressure drop from “P” to “B” for a valve with a type 2 spool, first locate 2 in the Spool Type column. The reference curve number at the intersection of the type 2 row and the P→B column is 3.

The pressure drop curves give approximate pressure drop (ΔP) when passing 21 cSt (100 SUS) fluid(s) having 0.865 specific gravity (G). To calculate the pressure drop for any other specific gravity (G_1), use the formula $\Delta P_1 = \Delta P(G_1/G)$. For any other viscosity, the pressure drop will change as follows:

Viscosity cSt (SUS)	Percentage of ΔP (approx.)
14 (75)	93
32 (150)	111
43 (200)	119
54 (250)	126
65 (300)	132
76 (350)	137
86 (400)	141

Pressure Drop Curves

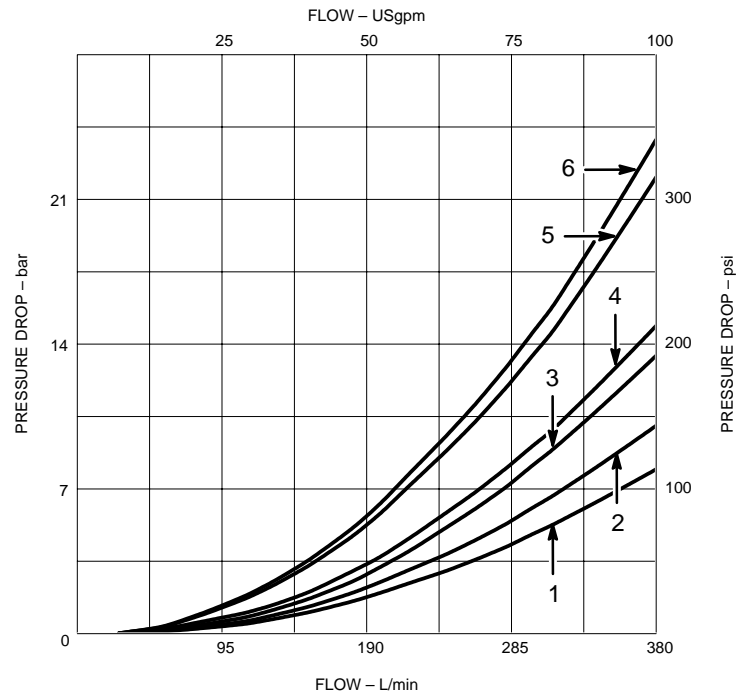

DG5S-8 Model Series

Dimensions in mm (inches)

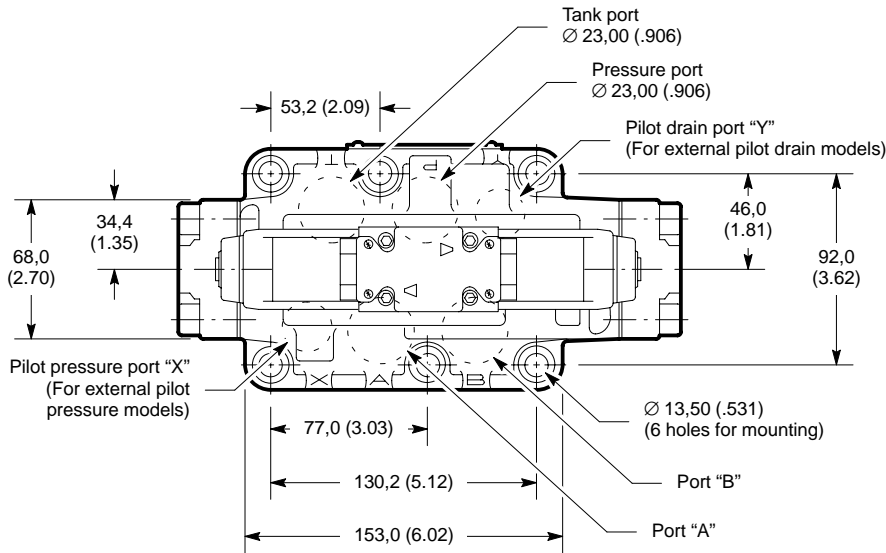

Clearance for removal
of solenoid coil
51 (2.01) AC DG4V-3
45 (1.77) AC DG4V-3S
61 (2.40) DC

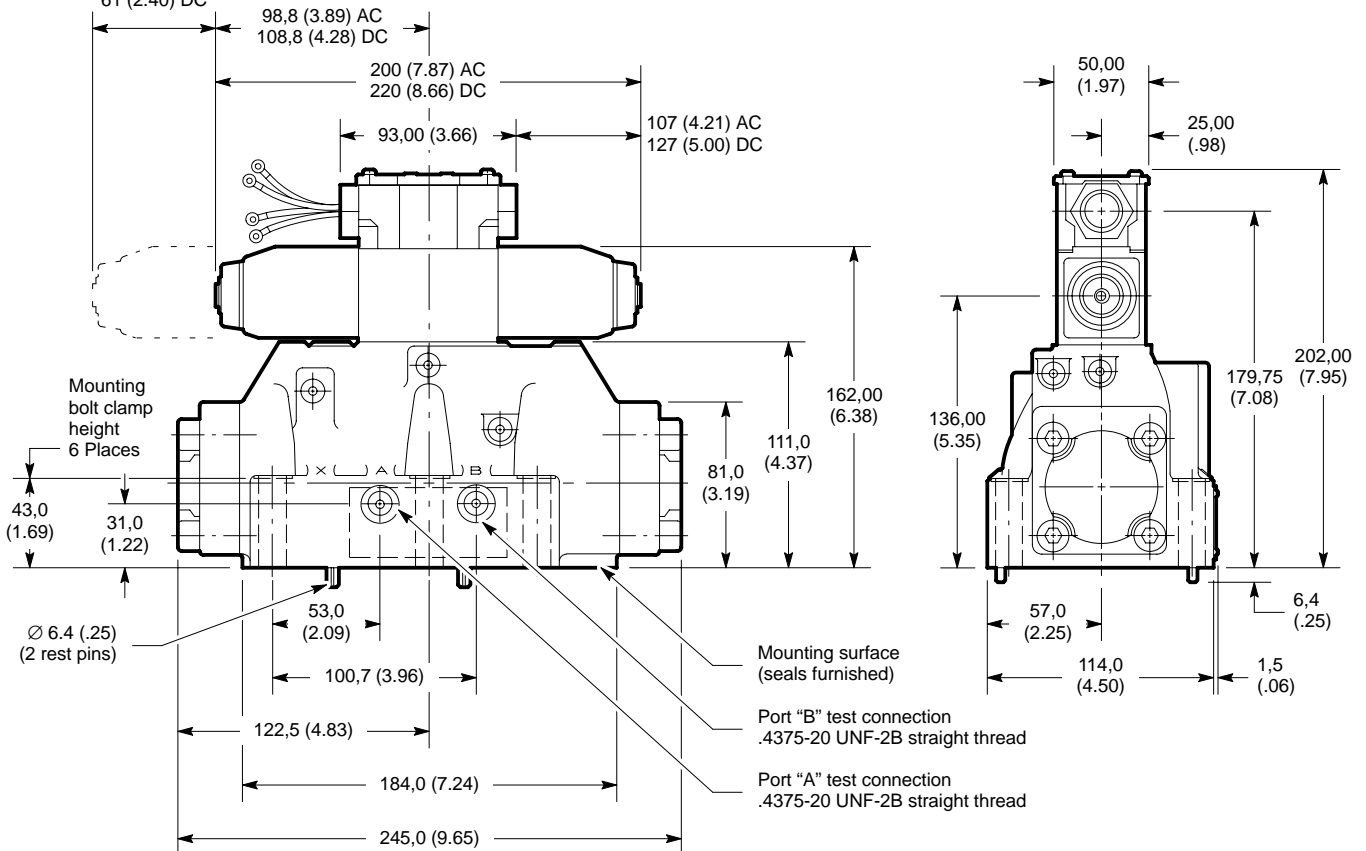

Pilot Choke and Stroke Adjustments

Pilot Choke Adjustment(s)

Pilot choke is adjusted by backing off locknuts and turning adjusting screws inward (clockwise) to decrease rate of spool travel and outward (counterclockwise) to increase the rate. Pilot oil for models with this feature should be taken from a source having a constant pressure. See spool control modifications in model code.

Stroke Adjustment(s)

Stroke adjustment limits movement of the main stage spool. Backing off the jam nut and turning the adjusting screw inward (clockwise) decreases spool stroke. See spool control modifications in model code.

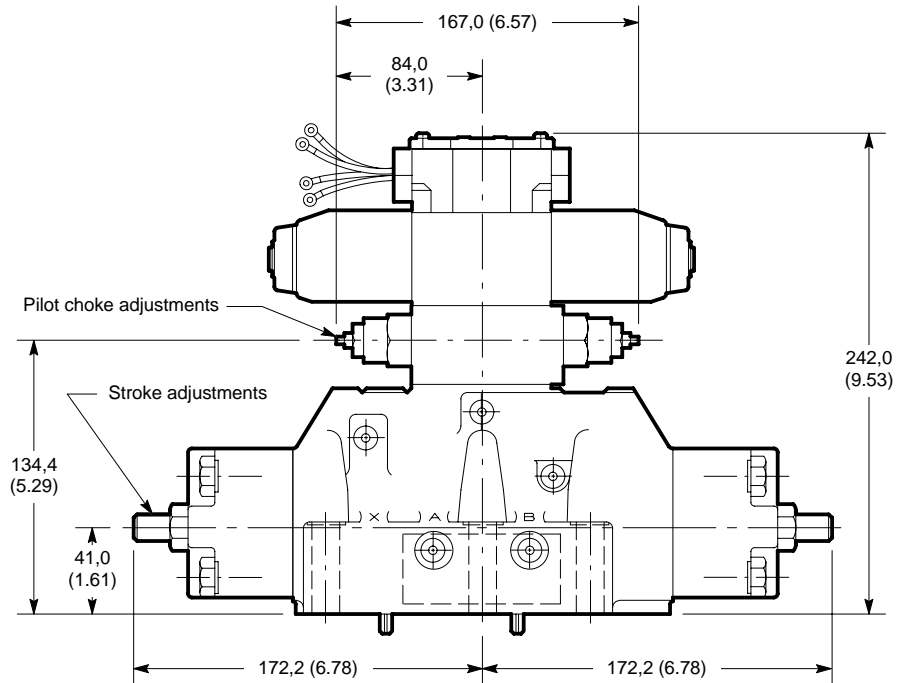

Pilot Valve Port Restrictor Plugs

Restrictor plugs are available for use in ports P, T, A, or B. These can be used for restricting flow or for circuit dampening. Restrictor plugs are not recommended for use above 210 bar (3000 psi) system pressure.

Part Number†	Orifice Ø	Model Code
694353	Blank	*00
694341	0,30 (0.012)	*03
694342	0,60 (0.024)	*06
694343	0,80 (0.030)	*08
694344	1,00 (0.040)	*10
694345	1,30 (0.050)	*13
694346	1,50 (0.060)	*15
694347	2,00 (0.080)	*20
694348	2,30 (0.090)	*23

† – Available in multiples of 25 per part number

* – P, T, A, or B as required

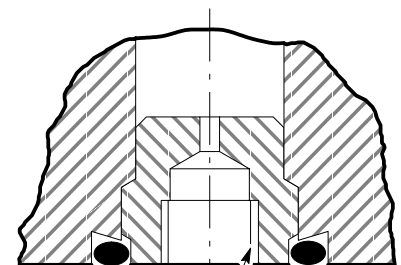

M5 x 0.8-6H thread
for plug extraction

DG5S-8 Model Series

Optional Features

Integral Check Valves

For Internal Pilot Pressure:

An integral pressure port check is required for "internally piloted" valves with open center spools (0, 1, 4, 8, 9, and 11). The pilot pressure generated is the total of the "P→T" drop through the valve in the center condition, the pressure drop through the check valve, and the pressure at the tank port. For proper operation, the total pressure drop must be greater than the minimum required pilot pressure (see chart).

To Prevent Load Drop:

A check valve in the pressure port can be used to prevent reverse flow from a cylinder port to the pressure port.

For minimum pilot pressure table see page 7

Pressure Centered Valves

This option provides faster spring centering time by using pilot pressure to center the spool. The centering springs are used in addition to pilot pressure to insure positive centering of the spool. The valve spool is returned to center position by pilot pressure and centering springs when both solenoids are de-energized. If pilot pressure fails or falls below the required minimum, the spool will return to center position at minimum pilot pressure flow rates for pressure centered valves. Pilot pressure is not available through use of an integral check valve. The pressure centering times for pressure centered models are shown in curves for various pilot pressures. See page 6.

Pressure Drop Across Check Valve

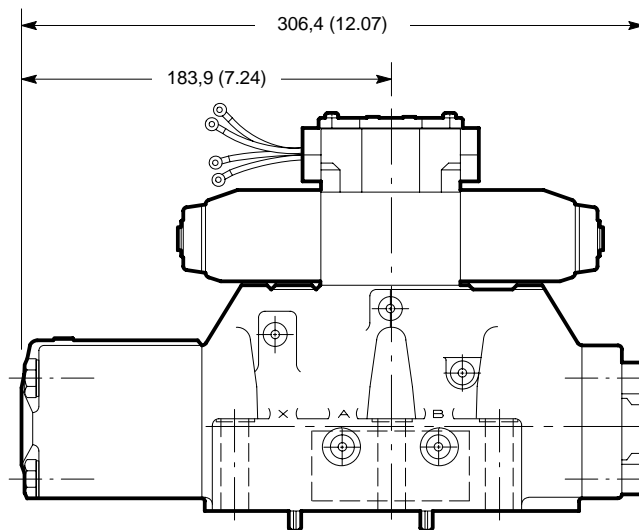
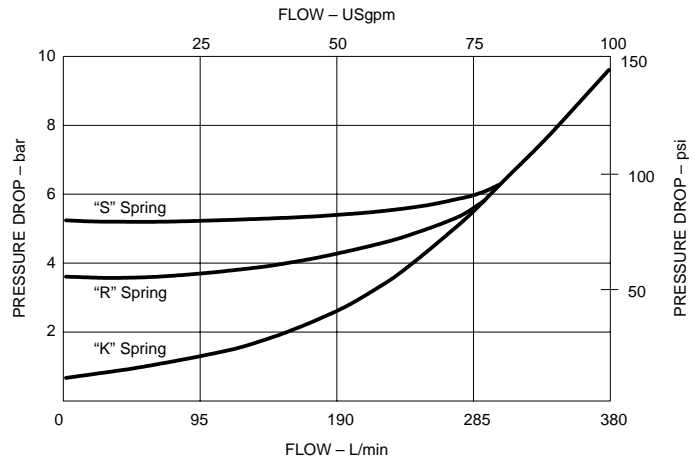

DG5S-H8 Model Series

Ratings

Recommended Flow* L/min (USgpm)	Maximum Operating Pressure (Ports P, A, & B) bar (psi)	Maximum Pilot Pressure bar (psi)	Maximum Tank Line Pressure bar (psi)		Mounting Pattern
			External Drain Models	Internal Drain Models	
To 265 (70)	310 (4500)	310 (4500)	310 (4500)	210 (3000)	ISO 4401-08, NFPA D08 (formerly D06), and ANSI B93.7

*See maximum flow table on page 17.

Model Codes

F3-DG5S-H8- ** (L)(*) (X)-(*)-(E)-(T)(*)-(V)M-(S*) * () ** (L)- ** 5- *** -6*/7***

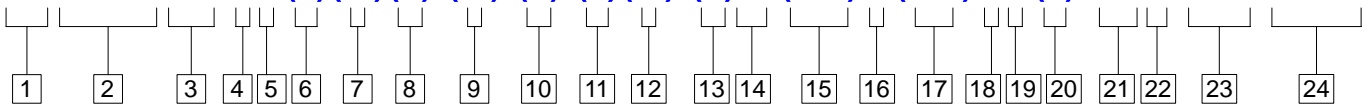

1 Viton seals
F3 – For mineral oil & fire resistant fluids
Blank – Omit if not required

2 Series designation
D – Directional control valve
G – Manifold or subplate mounted
5 – Solenoid controlled, pilot operated
S – Sliding spool, rated pressure 310 bar (4500 psi)

3 High flow interface
8 – NFPA D08 (ISO 4401-08)

4 Spool type
Code Center position
0 – Open to T all ports
1 – Open P & A to T, closed B
2 – Closed to T all ports
3 – Closed P & B, open A to T
4 – Tandem P to T, closed crossover
6 – Closed P only, open A & B to T
8 – Tandem P to T, open crossover
9 – Open to T all ports over tapers
11 – Open P & B to T, closed A
31 – Closed P & A, open B to T
33 – Closed P, open A & B to T over tapers

5 Spool/Spring arrangement
A – Spring offset to A port
B – Spring centered, solenoid A removed
C – Spring centered
F – Spring offset to A port, shift to center
N – No spring detented (pilot only)

6 Left hand assembly
L – Left hand, single solenoid only. Omit if not required. (For right hand assembly, P to A port when solenoid A is energized.)
Blank – Omit if not required

7 Manual override
Blank – Plain override solenoid ends only
H – Waterproof override solenoid ends only
H2 – Waterproof override both ends of single solenoid
P2 – Plain override both ends of single solenoid
Y – Lockable manual overrides solenoid ends only/DC only
Z – No overrides in either end

8 Response type
X – Fast response
Blank – Standard low shock models

9 Spool control modifications
1 – Stroke adjustment both ends
2 – Pilot choke (dual) adjustment
3 – Pilot choke and stroke adjustment
7 – Stroke adjustment A port end only
8 – Stroke adjustment B port end only
2-7 – Dual pilot choke and stroke adjustment A port end only
2-8 – Dual pilot choke and stroke adjustment B port end only
Blank – Omit if not required

10 Pilot pressure
E – External pilot pressure
Blank – Internal pilot pressure

11 Pilot drain
T – Internal pilot drain
Blank – External pilot drain

12 Pressure port check valve
K – 0,35 bar (5 psi) cracking pressure
R – 3,45 bar (50 psi) cracking pressure
S – 5,20 bar (75 psi) cracking pressure
Blank – Omit if not required

DG5S-H8 Model Series

Model Codes (continued)

13 Solenoid energization identity

V – Solenoid identification determined by position of solenoid (solenoid A at port A end and/or solenoid B at port B end)
 Blank – Standard arrangement for ANSI B93.9 (energize solenoid A for flow P to A port)
 (Code V for any valve with code 4 or code 8 spool)

14 Flag symbol

M – Electrical options and features

15 Spool indicator switch

(Available on models with high performance pilot DG4V3 only)
 S3 – Normally open (available on valves with code P* only)
 S4 – Normally closed (available on valves with code P* only)
 S5 – Free leads (available on valves with coil type code F only)
 S6 – LVDT type DC switch with Pg7 connector plug

16 Coil type

U – ISO 4400
 F – Flying lead
 SP1 – Single 6,3 mm spade to IEC 760
 SP2 – Dual 6,3 mm spade to IEC 760

17 Electrical connections

(Code F coil only)
 T – Wired terminal block
 PA – Instaplug male receptacle only
 PB – Instaplug male & female receptacle
 PA3 – Three pin connector
 PA5 – Five pin connector
 Blank – Omit if not required

18 Housing

(Code F coil only)
 W – 1/2 NPT thread wiring housing
 J – 20 mm thread wiring housing
 Blank – Omit if not required

19 Electrical options

(Code U coil only)
 1 – ISO with fitted plug
 6 – ISO with fitted plug and lights

20 Solenoid indicator lights

(Code F coil with code T electrical connections only)
 L – Indicator lights
 Blank – Omit if not required

21 Coil identification

A – 110V AC 50 Hz
 B – 110V AC 50 Hz/120V AC 60 Hz*
 C – 220V AC 50 Hz
 D – 220V AC 50 Hz/240V AC 60 Hz*
 G – 12 VDC
 H – 24 VDC
 DJ – 98 VDC
 P – 110 VDC

* For 60 Hz or dual frequency

22 Pilot valve tank pressure rating

2 – 10 bar (145 psi) DG4V3-60 with S3, S4, or S5 spool indicator switch
 5 – 100 bar (1450 psi) DG4V3S-60
 6 – 210 bar (3000 psi) DG4V3-60 with AC solenoids and optional S6 spool indicator switch
 7 – 210 bar (3000 psi) DG4V3-60 with DC solenoids and optional S6 spool indicator switch

23 Pilot valve port orifices

Code Orifice diameter
 *00 – Solid plug
 *03 – 0,30 mm (0.012 in)
 *06 – 0,60 mm (0.024 in)
 *08 – 0,80 mm (0.030 in)
 *10 – 1,00 mm (0.040 in)
 *13 – 1,30 mm (0.050 in)
 *15 – 1,50 mm (0.060 in)
 *20 – 2,00 mm (0.080 in)
 *23 – 2,30 mm (0.090 in)
 Blank – Omit if not required
 (* = P, T, A, and/or B as required)

24 Design number

60 – DG4V3S-60 pilot valve
 70 – DG4V3-60 pilot valve
 (Subject to change. Installation dimensions same for designs 60 through 69 and 70 through 79.)
 61 – For DG4V-3S-60 piloted valves with 4C/8C type special anti-spin main stage spools/spring.
 71 – For DG4V-3-60 piloted valves with 4C/8C type special anti-spin main stage spools/spring.

Performance Characteristics

Shift Time

Shift time is defined as the elapsed time from when the pilot valve solenoid is energized to the time the main stage spool shifts to its full stroke. Shift time curves are shown for standard low shock and fast response models at 210 bar (3000 psi) system pressure with various pilot pressures and spools. Pressure centering time curves are shown for pressure centered models. Approximate spring centering times are also listed for spring centered models.

Shifting Action

The pilot valve solenoids of spring centered and spring offset models must be energized continuously to keep the main stage spool in the shifted position. No-spring detented models only need to be energized momentarily (for approximately 0.1 second).

Spring centered models return the valve spool to the center position when both solenoids are de-energized or pilot pressure fails or falls below minimum requirements. Spring offset models return the spool to the offset position by pilot pressure when the solenoid is de-energized.

When no-spring detented models are de-energized, the pilot and main spools remain in their last position as long as there are no unusual shock, vibration, or pressure transients, and the spool axis is horizontal. If pilot pressure fails or falls below the minimum, the main spool will spring center (at spring centered flow rates), but will not drift to a reversal of flow position. The pilot stage will remain in the detented position.

CAUTION

Be careful when setting up flow conditions for the spring centered position of the main stage spool in no-spring detented models. Be sure to consider the effect of the direction of the flow and the pilot pressure. The type 9 main spool may not ensure sufficient pilot pressure in the center position.

Spring Centering Times at Rated Flow and Pressure

Spool Types	AC Models	DC Models
2, 3, 6, 31, 33	.076 sec	.088 sec
0, 1, 9, 11	.088 sec	.100 sec
4, 8	.110 sec	.130 sec

Fast Response

Valves with the fast response option have decreased shift time, but increased system shock generation. Fast response is available by adding the symbol "X" in the eighth position of the model code (example: DG5S-H8-2CX-M-W*-70). The shift time and centering time curves show both standard and fast response times. Because of the high drain line pressure transients generated during shifting, use of the fast response option is not recommended for pilot pressures exceeding 140 bar (2000 psi).

Shift Time For AC Models at Rated Flow and Pressure

(Add approximately 25 milliseconds for DC models)

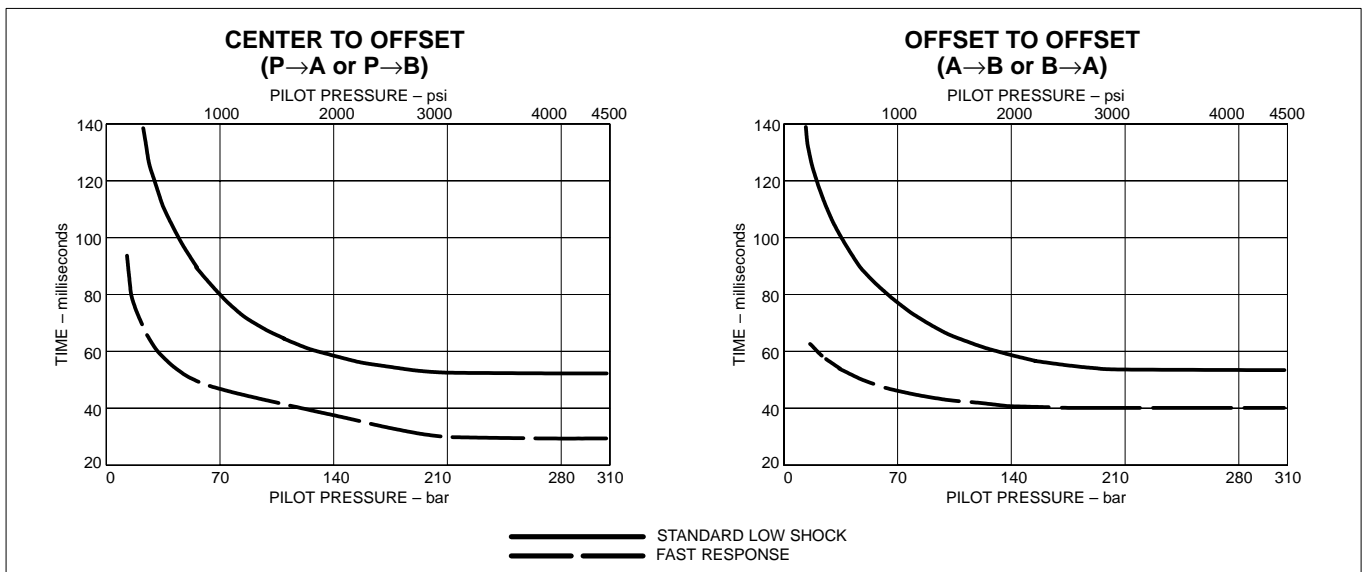

DG5S-H8 Model Series

Spool Type and Center Position

Spool Type	Center Position	Spool Type	Center Position	Spool Type	Center Position	Spool Type	Center Position
0		3		8		31	
1		4		9		33	
2		6		11			

Minimum Pilot Pressure Requirements

Spool-Spring Arrangement	Spool Type	Minimum Pilot Pressure bar (psi)	
		For Recommended Flow at System Pressure Up to 310 bar (4500 psi)	For Maximum flow Without Malfunction at System Pressure of 310 bar (4500 psi)
Spring Centered	0, 1, 4, 8, 9, and 11	5 (75)	5 (75)
Spring Offset	(open center)		
Shift to Center	2, 3, 6, 31, and 33	8 (120)	10 (150)
No-Spring Detented	(closed center)		

Application Guidance

The pilot pressure stated is based on internally piloted and externally drained models in which the pilot pressure is equal to pressure at the "P" port. With models having open center spools, pilot pressure can be assured by imposing a back pressure of at least the required minimum pilot pressure at the tank outlet connection (this back pressure will be present at cylinder ports if the spool type is 0, 1, 9, or 11), or by using an integral check valve that will not impose the additional pressure at the cylinder ports (see integral check valve note). Normally, internal pilot pressure for closed center spools is readily available. When pilot pressure from a separate source is required for either open or closed center spools, an external connection in the valve can be provided. (Add "E" to the model code.)

NOTE

Surges of oil in a common pilot valve drain line serving these and other valves can be of sufficient magnitude to cause inadvertent shifting of these valves. This is particularly critical in the no-spring detented type valves. Separate tank lines or a vented drain manifold with a continuous downward path to tank is necessary.

Any sliding spool, if held shifted under pressure for long periods of time, may stick and not spring return due to fluid residue formation (silting) and, therefore, should be cycled periodically to prevent this from happening.

When using as other than a normal four-way valve, consult your local Vickers representative.

Mounting Position

No-spring detented type valves must be installed with the longitudinal axis horizontal for good machine reliability. Mounting position of spring centered and spring offset valves is unrestricted provided that the pilot pressure is maintained as required. (Spring offset valves do not have a spring in the main spool section.)

Graphical Symbols

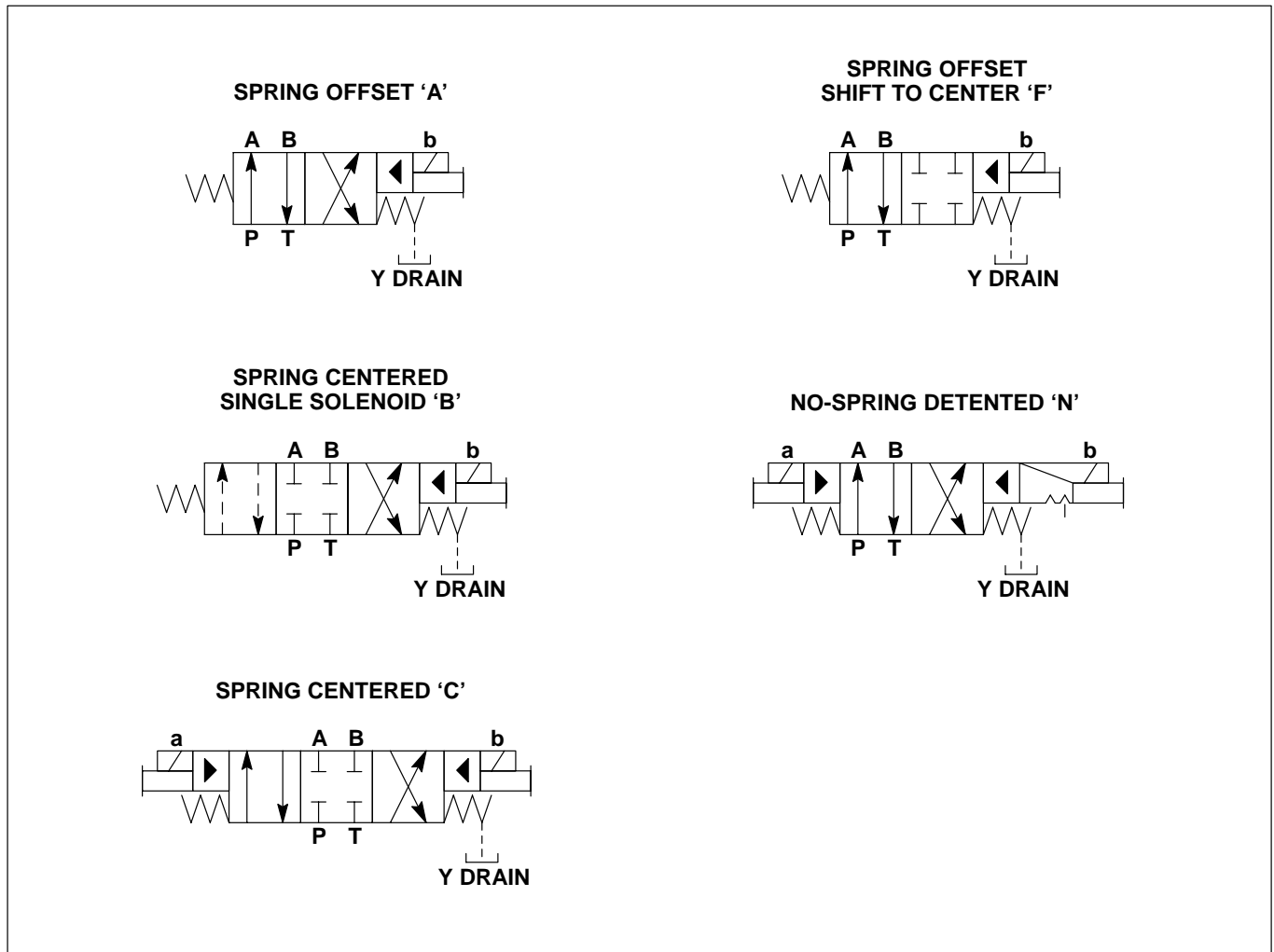

Flow Ratings

Valve Type	Spool Type	Recommended Flow Capacity at 210 bar (3000 psi) L/min (USgpm)	Maximum Flow Without Malfunction at:			
			70 bar (1000 psi) L/min (USgpm)	140 bar (2000 psi) L/min (USgpm)	210 to 310 bar (3000 to 4500 psi) L/min (USgpm)	
Spring Offset 'A'	0, 2, 6, 9, 33	265 (70)	530 (140)	530 (140)	530 (140)	530 (140)
Spring Centered Single Solenoid 'B'	0, 2, 3, 4, 6, 31, 33	265 (70)	530 (140)	530 (140)	530 (140)	530 (140)
Spring Centered 'C'	1, 11	265 (70)	530 (140)	530 (140)	530 (140)	454 (120)
Spring Offset Shift to Center 'F'	8	265 (70)	530 (140)	530 (140)	530 (140)	530 (140)†
No-Spring Detented 'N'	9	265 (70)	265 (70)	340 (90)	380 (100)	380 (100)
No-Spring Detented 'N'	0, 2, 6, 9, 33	265 (70)	530 (140)	530 (140)	530 (140)	530 (140)

† Fast valve switching of large oil volumes without adequate decompression circuitry can develop instantaneous flows well above maximum ratings. Type 4 and 8 spools may spin within body causing unusual valve body wear. With this and other spool types, valve malfunction may occur. Where these applications exist use DG5S-H8*-61/71 designs for special 4C/8C anti-spin spools/springs.

DG5S-H8 Model Series

Pressure Drop

The following table lists the appropriate pressure drop curve between ports for each spool type.

Spool Type	Pressure Drop Curve Number				
	P→A	B→T	P→B	A→T	P→T On Center
0	2	3	2	3	2
1	1	1	2	3	5
2	1	2	1	3	–
3	1	2	1	4	–
4	2	4	2	4	6
6	1	4	1	4	–
8	2	4	2	4	6
9	2	3	2	4	–
11	2	1	1	3	5
31	1	4	1	2	–
33	1	2	1	3	–

For example, to find the pressure drop from “P” to “B” for a valve with a type 2 spool, first locate 2 in the Spool Type column. The reference curve number at the intersection of the type 2 row and the P→B column is 1.

The pressure drop curves give approximate pressure drop (ΔP) when passing 21 cSt (100 SUS) fluid(s) having 0.865 specific gravity (G). To calculate the pressure drop for any other specific gravity (G_1), use the formula $\Delta P_1 = \Delta P(G_1/G)$. For any other viscosity, the pressure drop will change as follows:

Viscosity cSt (SUS)	Percentage of ΔP (approx.)
14 (75)	93
32 (150)	111
43 (200)	119
54 (250)	126
65 (300)	132
76 (350)	137
86 (400)	141

Pressure Drop Curves

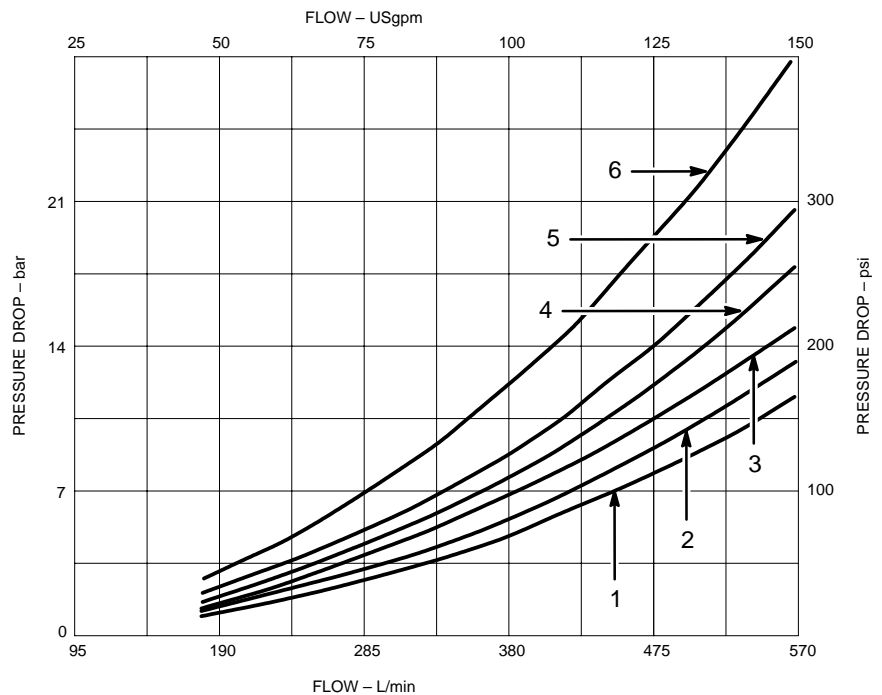

Dimensions in mm (inches)

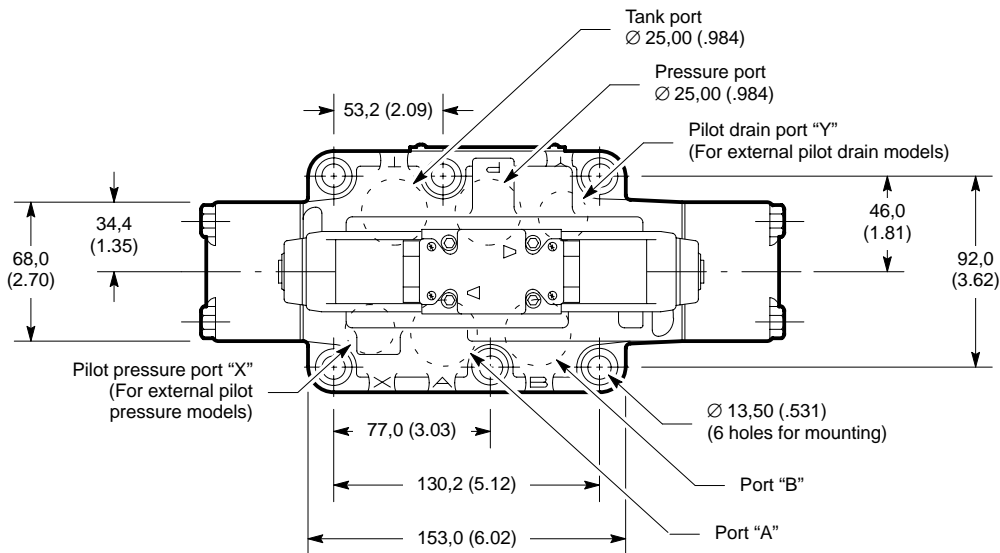

Clearance for removal
 of solenoid coil
 51 (2.01) AC DG4V-3
 45 (1.77) AC DG4V-3S
 61 (2.40) DC

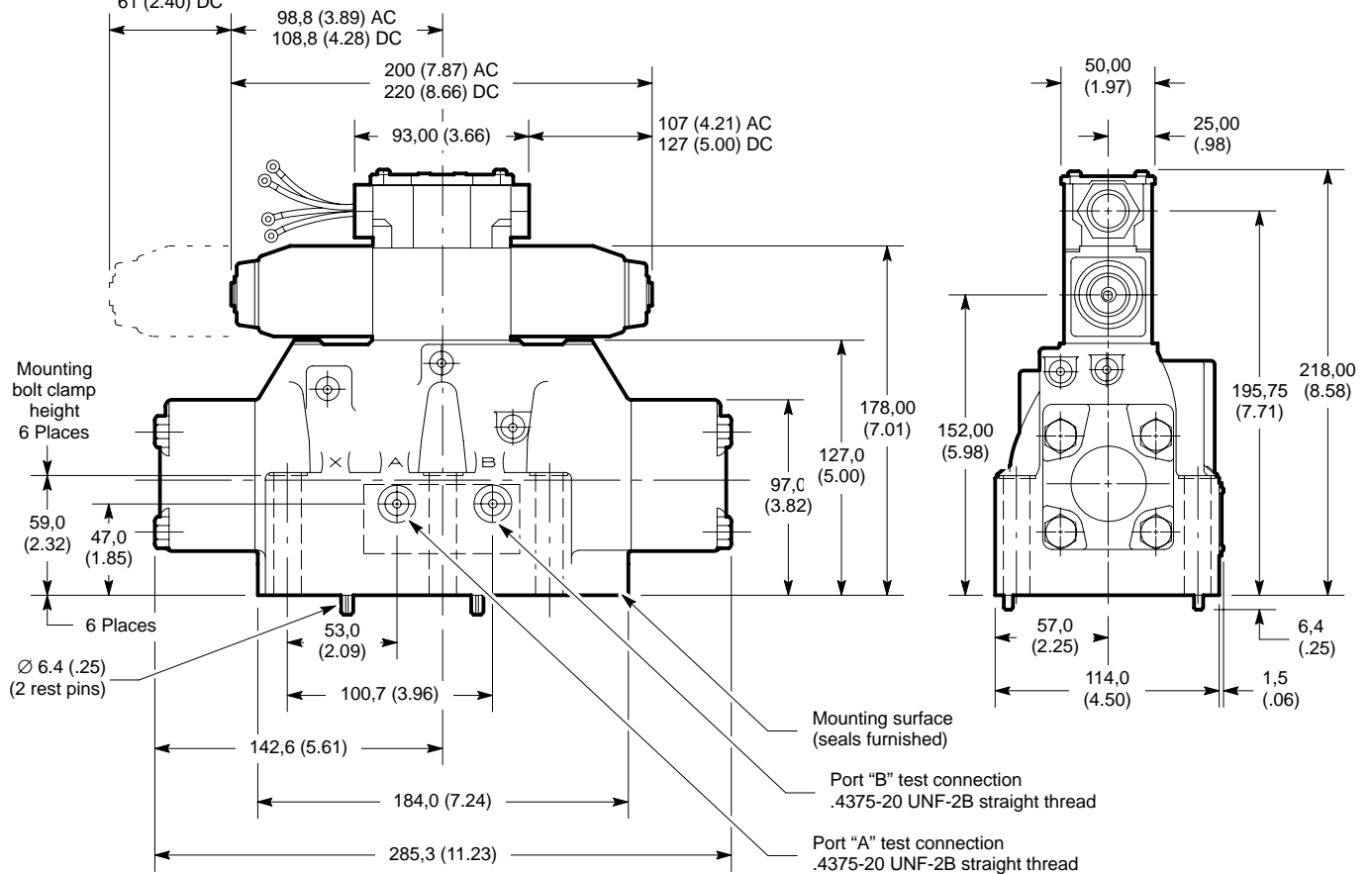

DG5S-H8 Model Series

Pilot Choke and Stroke Adjustments

Pilot Choke Adjustment(s)

Pilot choke is adjusted by backing off locknuts and turning adjusting screws inward (clockwise) to decrease rate of spool travel and outward (counterclockwise) to increase the rate. Pilot oil for models with this feature should be taken from a source having a constant pressure. See spool control modifications in model code

Stroke Adjustment(s)

Stroke adjustment limits movement of the main stage spool. Backing off the jam nut and turning the adjusting screw inward (clockwise) decreases spool stroke. See spool control modifications in model code.

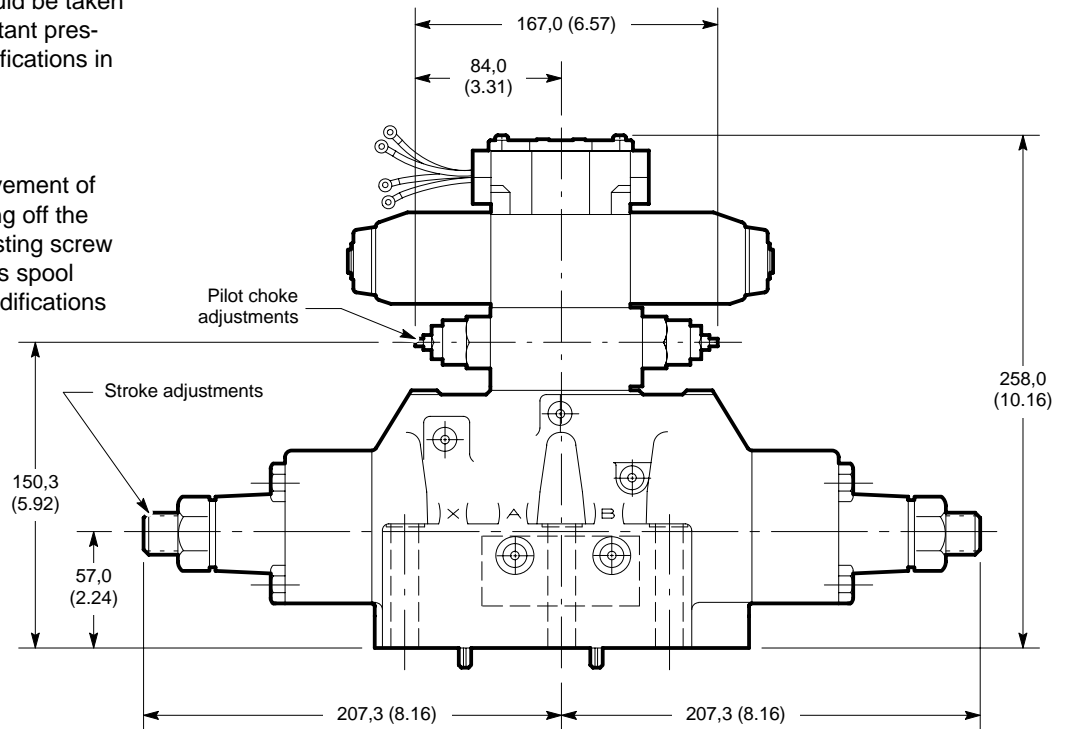

Pilot Valve Port Restrictor Plugs

Restrictor plugs are available for use in ports P, T, A, or B. These can be used for restricting flow or for circuit dampening. Restrictor plugs are not recommended for use above 210 bar (3000 psi) system pressure.

Part Number†	Orifice Ø	Model Code
694353	Blank	*00
694341	0,30 (0.012)	*03
694342	0,60 (0.024)	*06
694343	0,80 (0.030)	*08
694344	1,00 (0.040)	*10
694345	1,30 (0.050)	*13
694346	1,50 (0.060)	*15
694347	2,00 (0.080)	*20
694348	2,30 (0.090)	*23

† – Available in multiples of 25 per part number

* – P, T, A, or B as required

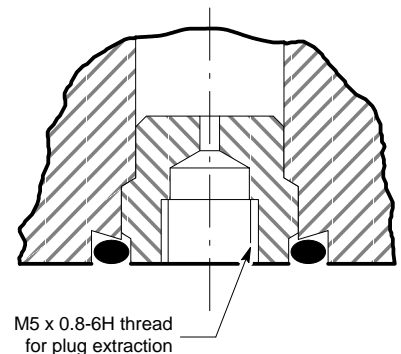

Optional Features

Integral Check Valves

For Internal Pilot Pressure:

An integral pressure port check is required for "internally piloted" valves with open center spools (0, 1, 4, 8, 9, and 11). The pilot pressure generated is the total of the "P→T" drop through the valve in the center condition, the pressure drop through the check valve, and the pressure at the tank port. For proper operation, the total pressure drop must be greater than the minimum required pilot pressure (see chart).

To Prevent Load Drop:

A check valve in the pressure port can be used to prevent reverse flow from a cylinder port to the pressure port.

For minimum pilot pressure table see page 16

Pressure Drop Across Check Valve

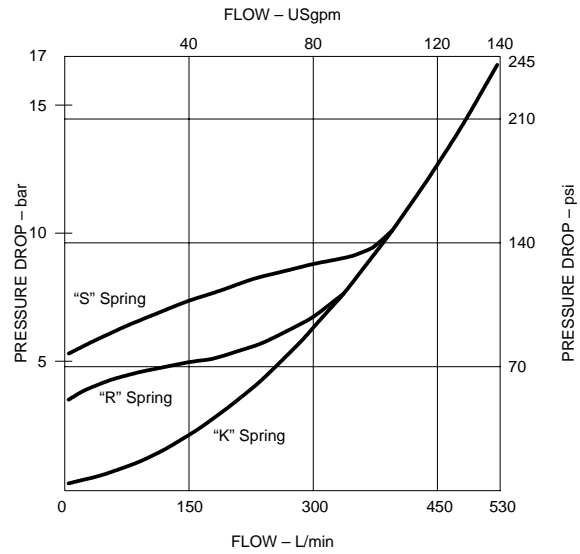

Accessories and Weights

Mounting Subplates

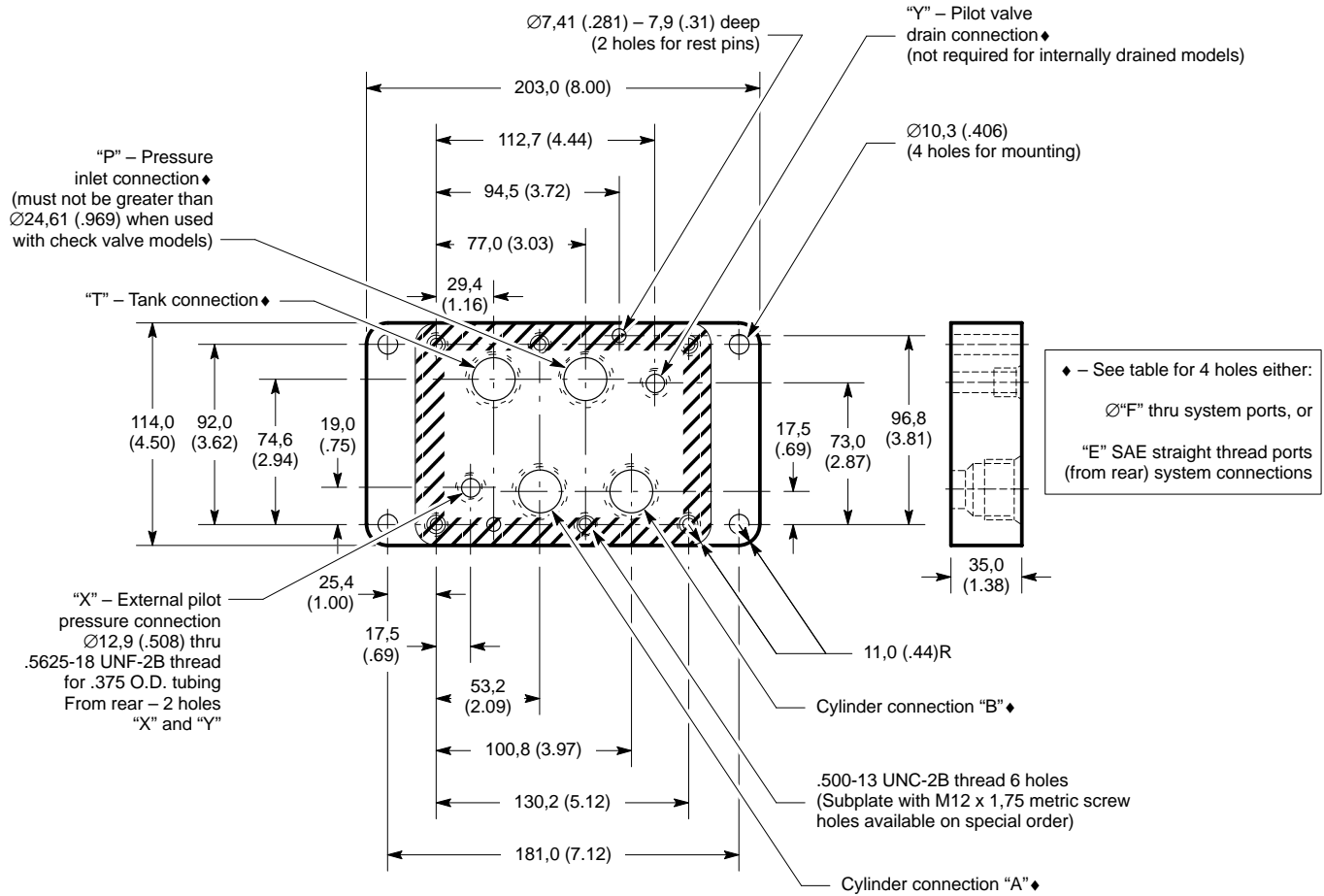

Model	"E" Thread	Tubing O.D.	"F" Diameter	Weight (approx.)
DGSM-8-10-T12	1.0625-12 UN	.750	23,79 (.937)	
DGSM-8-10-T16	1.3125-12 UN	1.000	24,61 (.969)	4,9 kg. (11 lb.)
DGSM-8-10-T20	1.6250-12 UN	1.250		

Bolt Kits

Bolt kits are used for mounting valves to a subplate or manifold. Valves, subplates, and mounting bolts must be ordered separately.

Two center mounting bolts are optional. All six bolts are recommended for

maximum seal life at pressures of 140 bar (2000 psi) and higher.

When a subplate is not used, a machined pad (as indicated by subplate shaded area) must be provided for mounting. The pad must be flat within 0,0013 mm (0.0005 inch) and smooth

within 1,6 μ m (63 microinch). If mounting bolts are provided by the customer, they should be SAE grade 7 or better.

The maximum recommended mounting bolt torque is 79 N-m (700 lb (f) in).

Model and Assembly Numbers

Model Series	Kit Model Number	Quantity	Thread Size \times Length	Assembly Number
DG5S-8	BKDG06635 (inch bolts)	6	.500-13 \times 2.50"	255635
	BKDG8655M (metric bolts)	6	M12 \times 65 mm	255655
DG5S-H8	BKDGH06618 (inch bolts)	6	.500-13 UNC \times 3.00"	255618
	BKDGH8658M (metric bolts)	6	M12 \times 80 mm	255658

Valve Weights

Model Series	Pilot Valve Solenoids	Additional Features	Weight kg (lbs)
DG5S-8	1	–	14,5 (32)
	2	–	15,0 (33)
	2	Pressure centered	16,8 (37)
	2	Pilot choke (meter out)	16,1 (35.5)
	2	Stroke adjustment (one end)	15,7 (34.5)
	2	Stroke adjustment (both ends)	16,4 (36)
	2	Pilot choke and stroke adjustment (both ends)	17,5 (38.5)
DG5S-H8	1	–	16,8 (37)
	2	–	17,3 (38)
	2	Pilot choke (meter out)	18,4 (40.5)
	2	Stroke adjustment (one end)	17,8 (39)
	2	Stroke adjustment (both ends)	18,2 (40)
	2	Pilot choke and stroke adjustment (both ends)	19,3 (42.5)

Installation and Application Data

Fluids and Seals

The use of synthetic fire resistant fluids requires valve with special seals (fluorocarbon).

Add prefix "F3" to model number when phosphate ester fluids or their blends are to be used. Water glycol, water-in-oil emulsions, and petroleum oil may be used with standard (Buna-N) seals. Refer to Vickers data sheet I-286-S, "Hydraulic Fluid and Temperature Recommendations for Industrial Machinery" for fluid and temperature recommendations. Pilot valve has "F3" seals (fluorocarbon) as standard. All internal seals in main stage are also "F3" seals. Mounting face seals are standard (Buna-N) seals.

Electrical Information

Refer to Vickers publication GB-C-2015B for details on solenoids, solenoid indicator lights, terminal strips, German DIN Standard 43650 plugs, Vickers "Insta-Plugs", and NFPA Standard T3.5.29-1980 electrical connectors.

Installation and Application Data

Pilot Valve Drain (Internal/External)

“Internal Drain” models drain the pilot valve through the tank port of the main stage. “External Drain” models drain the pilot valve through the “Y” port of the main stage. To provide proper operation without malfunction, the pilot pressure **must always** exceed tank or drain line pressure by the “Minimum Pilot Pressure” required per valve and spool type. (Refer to minimum pilot pressure table see page 16) Tank or drain line surges which would reduce this differential are to be avoided. Such surges may cause the main stage spool to shift.

Main stage tank pressure is limited to the tank line rating of the pilot valve on “Internal Drained” models (those that

include “T” in the model code). “Internal Drain” may be used with all models, except the DG5S-8 model series pressure centered “D” models. Pressure centered valves must be externally drained through “Y” and “W” ports. To achieve the maximum tank line rating (3000 psi) of the main stage an “External” pilot drain must be used, and it is recommended that a separate line be provided directly to tank.

Fluid Cleanliness

Proper fluid condition is essential for long and satisfactory life of hydraulic components and systems. Hydraulic fluid must have the correct balance of cleanliness, materials, and additives for protection against wear of components, elevated viscosity, and inclusion of air.

Vickers supports and recommends the hydraulic Systems Standards For Stationary Industrial Machinery advanced by the American National Standards Institute; ANSI/(NFPA/JIC) T2.24.2-1991. Key elements of the Standard, as well as other vital information on the correct methods for treating hydraulic fluid, are included in Vickers publication 561 “Vickers Guide to Systemic Contamination Control” available from your local Vickers distributor or by contacting Vickers, Incorporated. Recommendations on filtration and the selection of products to control fluid condition are included in this publication.

Recommended cleanliness levels using petroleum oil under common conditions is based on the highest fluid pressure levels in the system:

Product	System Pressure Level		
	1000 psi	2000 psi	3000+ psi
Directional Valves	20/18/15	20/18/15	19/17/14

Fluids other than petroleum, severe service cycles, or temperature extremes are cause for adjustment of these cleanliness codes. See Vickers publication 561 for exact details.

Алматы (7273)495-231
Ангарск (3955)60-70-56
Архангельск (8182)63-90-72
Астрахань (8512)99-46-04
Барнаул (3852)73-04-60
Белгород (4722)40-23-64
Благовещенск (4162)22-76-07
Брянск (4832)59-03-52
Владивосток (423)249-28-31
Владикавказ (8672)28-90-48
Владимир (4922)49-43-18
Волгоград (844)278-03-48
Вологда (8172)26-41-59
Воронеж (473)204-51-73
Екатеринбург (343)384-55-89

Иваново (4932)77-34-06
Ижевск (3412)26-03-58
Иркутск (395)279-98-46
Казань (843)206-01-48
Калининград (4012)72-03-81
Калуга (4842)92-23-67
Кемерово (3842)65-04-62
Киров (8332)68-02-04
Коломна (4966)23-41-49
Кострома (4942)77-07-48
Краснодар (861)203-40-90
Красноярск (391)204-63-61
Курск (4712)77-13-04
Курган (3522)50-90-47
Липецк (4742)52-20-81

Магнитогорск (3519)55-03-13
Москва (495)268-04-70
Мурманск (8152)59-64-93
Набережные Челны (8552)20-53-41
Нижний Новгород (831)429-08-12
Новокузнецк (3843)20-46-81
Ноябрьск (3496)41-32-12
Новосибирск (383)227-86-73
Омск (3812)21-46-40
Орел (4862)44-53-42
Оренбург (3532)37-68-04
Пенза (8412)22-31-16
Петрозаводск (8142)55-98-37
Псков (8112)59-10-37
Пермь (342)205-81-47

Ростов-на-Дону (863)308-18-15
Рязань (4912)46-61-64
Самара (846)206-03-16
Санкт-Петербург (812)309-46-40
Саратов (845)249-38-78
Севастополь (8692)22-31-93
Саранск (8342)22-96-24
Симферополь (3652)67-13-56
Смоленск (4812)29-41-54
Сочи (862)225-72-31
Ставрополь (8652)20-65-13
Сургут (3462)77-98-35
Сыктывкар (8212)25-95-17
Тамбов (4752)50-40-97
Тверь (4822)63-31-35

Тольятти (8482)63-91-07
Томск (3822)98-41-53
Тула (4872)33-79-87
Тюмень (3452)66-21-18
Ульяновск (8422)24-23-59
Улан-Удэ (3012)59-97-51
Уфа (347)229-48-12
Хабаровск (4212)92-98-04
Чебоксары (8352)28-53-07
Челябинск (351)202-03-61
Череповец (8202)49-02-64
Чита (3022)38-34-83
Якутск (4112)23-90-97
Ярославль (4852)69-52-93

Россия +7(495)268-04-70

Казахстан +7(7172)727-132

Киргизия +996(312)96-26-47

<https://vickers.nt-rt.ru> || vsh@nt-rt.ru