

Алматы (7273)495-231
Ангарск (3955)60-70-56
Архангельск (8182)63-90-72
Астрахань (8512)99-46-04
Барнаул (3852)73-04-60
Белгород (4722)40-23-64
Благовещенск (4162)22-76-07
Брянск (4832)59-03-52
Владивосток (423)249-28-31
Владикавказ (8672)28-90-48
Владимир (4922)49-43-18
Волгоград (844)278-03-48
Вологда (8172)26-41-59
Воронеж (473)204-51-73
Екатеринбург (343)384-55-89

Иваново (4932)77-34-06
Ижевск (3412)26-03-58
Иркутск (395)279-98-46
Казань (843)206-01-48
Калининград (4012)72-03-81
Калуга (4842)92-23-67
Кемерово (3842)65-04-62
Киров (8332)68-02-04
Коломна (4966)23-41-49
Кострома (4942)77-07-48
Краснодар (861)203-40-90
Красноярск (391)204-63-61
Курск (4712)77-13-04
Курган (3522)50-90-47
Липецк (4742)52-20-81

Магнитогорск (3519)55-03-13
Москва (495)268-04-70
Мурманск (8152)59-64-93
Набережные Челны (8552)20-53-41
Нижний Новгород (831)429-08-12
Новокузнецк (3843)20-46-81
Ноябрьск (3496)41-32-12
Новосибирск (383)227-86-73
Омск (3812)21-46-40
Орел (4862)44-53-42
Оренбург (3532)37-68-04
Пенза (8412)22-31-16
Петрозаводск (8142)55-98-37
Псков (8112)59-10-37
Пермь (342)205-81-47

Ростов-на-Дону (863)308-18-15
Рязань (4912)46-61-64
Самара (846)206-03-16
Санкт-Петербург (812)309-46-40
Саратов (845)249-38-78
Севастополь (8692)22-31-93
Саранск (8342)22-96-24
Симферополь (3652)67-13-56
Смоленск (4812)29-41-54
Сочи (862)225-72-31
Ставрополь (8652)20-65-13
Сургут (3462)77-98-35
Сыктывкар (8212)25-95-17
Тамбов (4752)50-40-97
Тверь (4822)63-31-35

Тольятти (8482)63-91-07
Томск (3822)98-41-53
Тула (4872)33-79-87
Тюмень (3452)66-21-18
Ульяновск (8422)24-23-59
Улан-Удэ (3012)59-97-51
Уфа (347)229-48-12
Хабаровск (4212)92-98-04
Чебоксары (8352)28-53-07
Челябинск (351)202-03-61
Череповец (8202)49-02-64
Чита (3022)38-34-83
Якутск (4112)23-90-97
Ярославль (4852)69-52-93

Россия +7(495)268-04-70

Казахстан +7(7172)727-132

Киргизия +996(312)96-26-47

<https://vickers.nt-rt.ru> || vsh@nt-rt.ru

Proportional Directional Control Valves

K(A)DG5V-5/7/8 & KDG5V-10, 1* Series,
Two-Stage Models without Electrical Feedback
ISO 4401 Sizes 05, 07,08 and 10 ANSI/B93.7M-D07/08/09

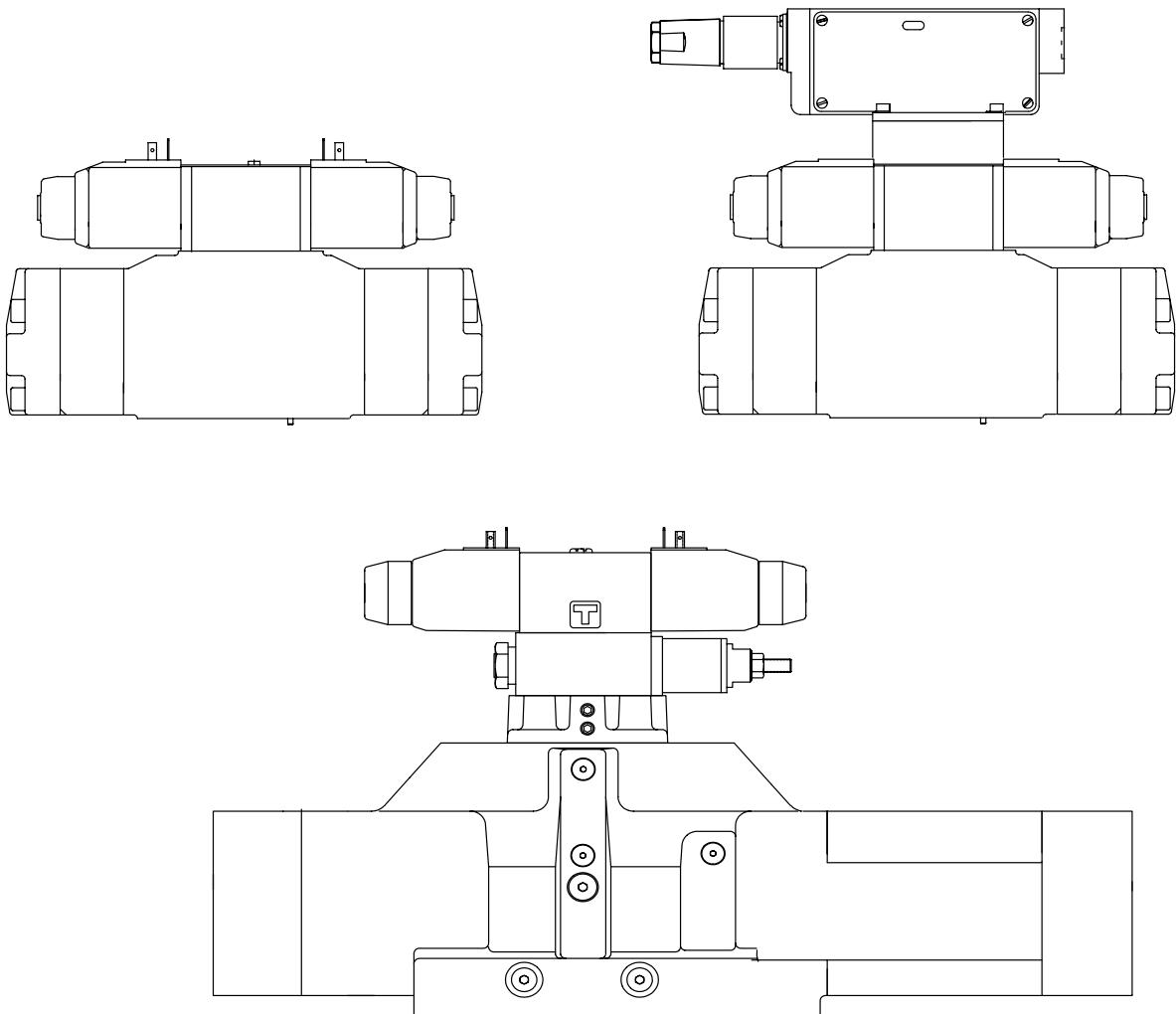

Introduction

Vickers KDG5V-5/7/8/10 are solenoid operated directional control non-feedback type proportional valves.

Two-stage proportional directional control valves in which the main-stage spool is positioned according to the output from an integrally mounted proportional, solenoid-operated, pressure-reducing valve. Direction of main-spool travel depends upon which of the two solenoids of the pilot valve is energized and the amount of travel is dependent upon the current input to the solenoid.

At any intermediate position of the main spool, a force balance exists between the controlled, reduced pilot pressure acting on the spool end and the opposing centering spring, plus the action of flow forces. There is no electrical feedback of the main-stage spool position.

This range of valves offers effective and economic solutions for applications having repetitive load conditions throughout each operating cycle, e.g. mold closure/opening in plastics molding machinery.

Valve sizes 5,7 & 8 are available with integral amplifiers.

Features and Benefits

- These global products, manufactured to world-class quality standards, are sold and serviced throughout the world.
- These valves open up expanded application opportunities as a cost effective alternative to feedback-type proportional and servo valves.
- Vickers flexible design approach provides a wide variety of matching electronic amplifiers, valve options, and spool ratings.

Typical Section Views

**KDG5V-7 shown without "EX" or "X"
(Without integral pilot pressure reducer)**

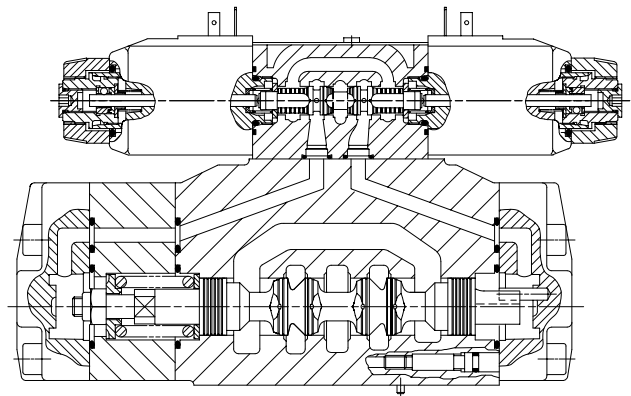

**KDG5V-10 shown with "EX" or "X"
(With integral pilot pressure reducer)**

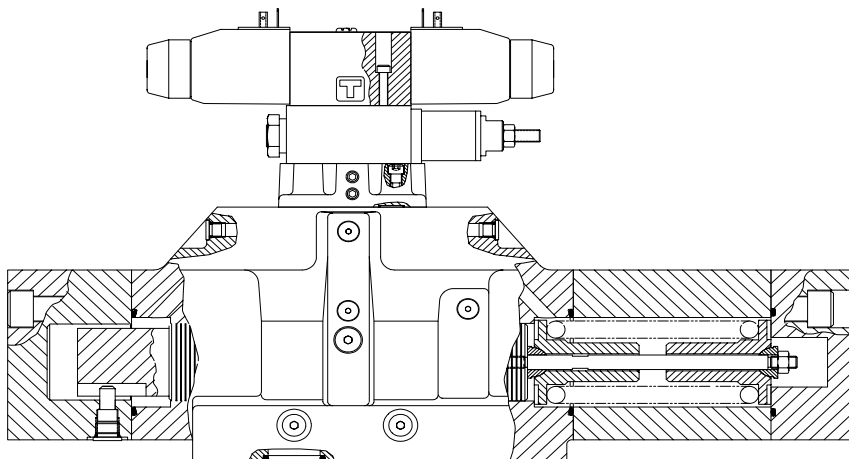
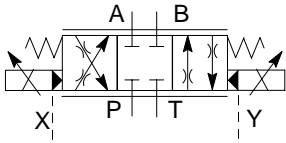

Table of Contents

Introduction	B.2
Features and benefits	B.2
Typical section	B.2
Functional Symbols	B.4
Model Codes	B.5
Spool Data	B.6
Operating Data	B.7
Performance Characteristics	B.9
Installation Dimensions	B.12
Subplates, Connection Plates and Mounting Surfaces	B.17
Electrical Information	B.31
Installation Data	B.38
Application Data	B.39

Functional Symbols



Simplified symbol
KDG5V models
(Spool type "2" shown)

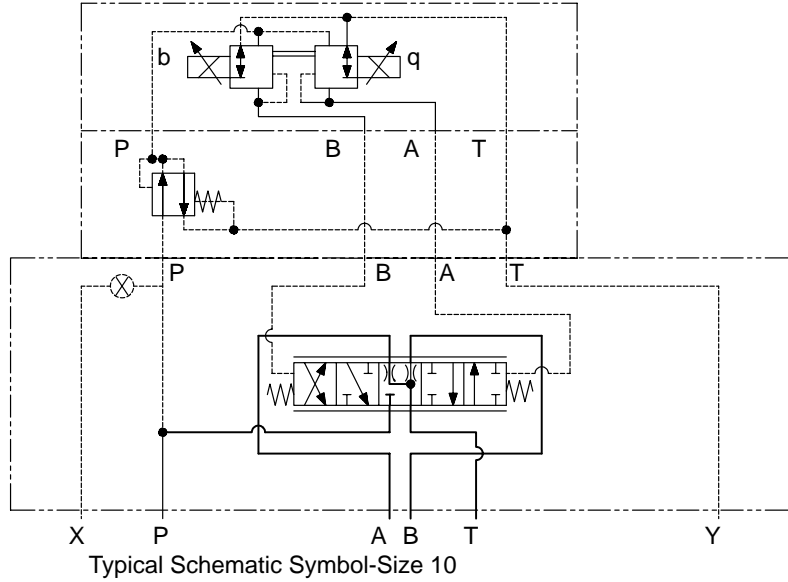

Typical Schematic Symbol-Size 10

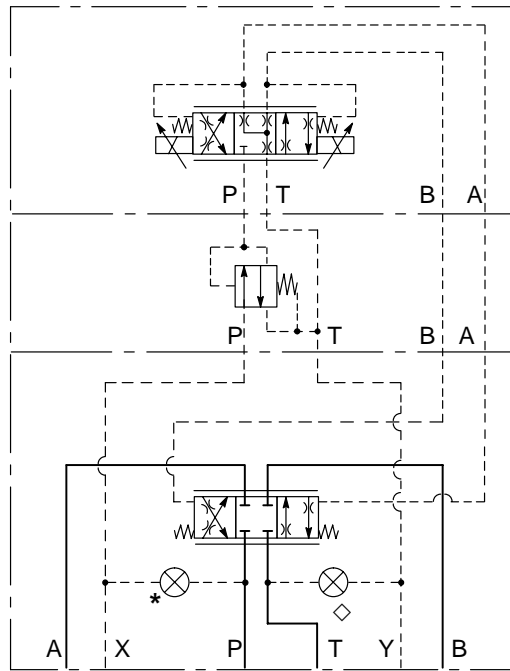

Typical Schematic Symbol-Sizes 5/7/8

Pilot stage.
Solenoids identified
"A"/"B" according to
"Model Code"
designation.

Pressure reducer
module, see "Model
Code"

Main-stage.
Spool type "2C" shown

* Internal plug shown, for external pilot supply (via port X).

For internal pilot supply (from port P) plug is not fitted. Port X should be blocked at mounting interface, or otherwise plugged at subplate or manifold block. See "Model Code".

◇ Internal plug shown, for external pilot drain (via port Y).

For internal pilot drain (via port T) plug is not fitted. Port Y should be blocked at mounting interface, or otherwise plugged at subplate or manifold block. See "Model Code".

See also "Pilot Drain Application" notes.

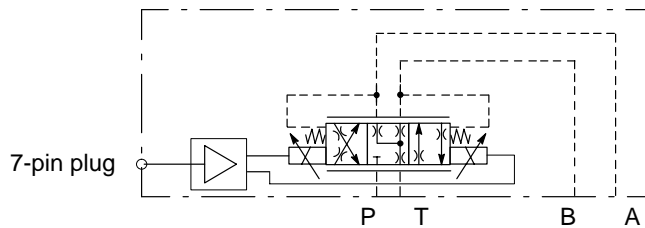

Pilot stage with
integral amplifier

Model Codes

K(A)DG5V - * - * C *** N (***) - (**)- (T)- (*) - (V) M - ***** -1 - 1*- EN47**

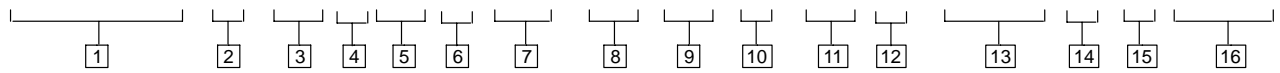

1 Model Series

K- Proportional
 A- Integral amplifier, sizes 5 / 7 & 8 only
 D- Directional valve
 G- Subplate/manifold mounted
 5- Solenoid controlled/pilot operated
 V- Pressure rating 350 bar (5000 psi) on P, A & B ports

2 Mounting interface size (ISO 4401)

5 = NFPA D05, CETOP 5
 7 = NFPA D07, CETOP 7
 8 = NFPA D08, CETOP 8
 10 = NFPA D10, CETOP 10

3 Spool type

See "Spool Data", page B.6
 2 = All ports blocked when spool centered
 7 = Open P to A&B,
 12 = All ports blocked when spool centered, regenerative function when spool energized
 33/133 = Bleed A and B to T when spool centered

4 Spool/ spring arrangement

C = Spool spring centered

5 Flow rating

See "Spool Data", page B.6
 Flow rating (L/min) for symmetric spools: "A" port flow rating (L/min) for asymmetric spools

6 Spool metering type

N = Meter-in and meter-out

7 Flow rating

See "Spool Data", page B.6
 "B" port flow rating (L/min) for asymmetric spools

8 Pilot supply

Models without integral, fixed pilot pressure reducer module
 E = External pilot supply
 Blank=Internal pilot supply
 Models with integral, fixed pilot pressure reducer module
 X = Internal pilot supply
 EX = External pilot supply

For system pressures less than 200 bar (2900 psi) the pilot pressure reducing module is optional.
 For system pressures above 200 bar (2900 psi) the pilot pressure reducing module must be fitted.

9 Pilot drain

T = Internal pilot drain
 Blank = External pilot drain

10 Manual override

Blank = Plain overrides
 H = Water-resistant overrides
 Z = No overrides

11 Solenoid identity

V = Solenoid "A" at port A end of pilot valve, solenoid "B" at B end. (Energizing "A" gives main-stage flow from port B; energizing "B" gives flow from port A): German practice.

Blank=Solenoid "A" energized for main-stage flow from port A; solenoid "B" energized for main-stage flow from port B: USA ANSI B93./NFPA standard.

12 Heading electrical flag symbol

M = Features and options for pilot valve

13 Electrical data and connection type

Plug connector type to ISO 4400 (DIN 43650). For coil characteristics see "Operating Data" table (page B.7):
 U-G = For use with amplifier with 12V DC supply
 U-GP = For use with 12V power
 U-H = For use with amplifier with 24V DC supply
 U-HA = For use with 24V power plug
 U-HR = For use with 800 mA power supply
 F-PD7 = 7-pin connector with plastic plug.
 See warning note below

14 Pilot drain pressure

1 = Standard

(See Pilot Drain Application Notes, page B.9)

15 Design number, 10 series

Subject to change. Installation dimensions unaltered for design numbers 10 to 19 respectively.

16 Special features

EN47 used with P type coil connection and Uniplug connector. Omit if not required



Warning

To conform to the EC Electromagnetic Compatibility directive (EMC) this KACG valve must be fitted with a metal 7-pin plug. The screen of the cable must be securely connected to the shell of the metal connector. A suitable IP67 rated connector is available from Vickers, part no. 934939. Alternatively a non IP67 rated connector is available from ITT-Cannon, part no. CA 02 COM-E 14S A7 P. The plastic plug, part number 694534, is only suitable for use in a sealed electromagnetic environment or outside of the European Community.

Spool Data

Spool Symbols

Simplified symbols including transient flow conditions (dotted line).

Spool type 2C

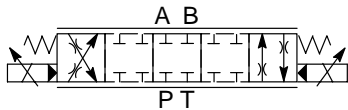

Spool type 7C

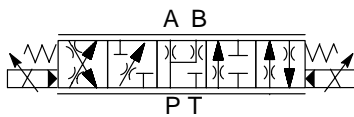

Spool type 12C

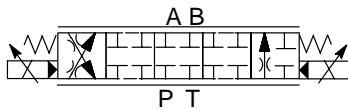

Spool type 33C

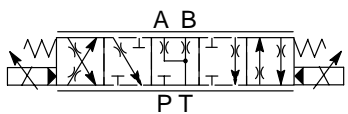

Spool type 133C, with typical regenerative circuit

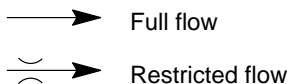
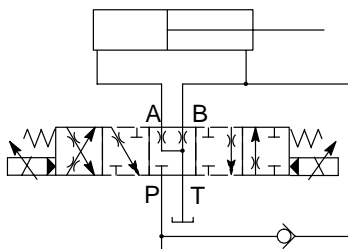

Spool Types and Flow Ratings

Symmetric Spools

Flow ratings for flow through P-A-B-T at $\Delta p = 5$ bar (72 psi) per flow path, e.g. P-A, or B-T. For other pressure drop values see "Flow Gain" curves on page B.10.

Spool code	Main stage spool symbol	Flow rating
For K(A)DG5V-5 valves:		
2C90N	2C	90 L/min (24 USgpm)
33C80N	33C	80 L/min (21 USgpm)
For K(A)DG5V-7 valves:		
2C180N	2C	180 L/min (48 USgpm)
33C170N	33C	170 L/min (45 USgpm)
For K(A)DG5V-8 valves:		
2C280N	2C	280 L/min (74 USgpm)
33C270N	33C	270 L/min (71 USgpm)
For KDG5V-10 valves:		
2C550N	2C	550 L/min (145 USgpm)
7C550N	7C	550 L/min (145 USgpm)
12C550N	12C	550 L/min (145 USgpm)
33C550N	33C	550 L/min (145 USgpm)
133C550N	133C	550 L/min (145 USgpm)

Asymmetric Spools

Figure preceding metering type designator, "N" (e.g. 2C***N) is flow rating P-A, or A-T ("A" port flow); figure after "N" (N***N) is flow rating P-B, or B-T ("B" port flow).

Spool code	Main stage spool symbol	Flow rating
For K(A)DG5V-5 valves:		
2C70N45	2C	70 L/min (18.5 USgpm), "A" port flow 45 L/min (12 USgpm), "B" port flow
For K(A)DG5V-7 valves:		
2C180N100	2C	180 L/min (48 USgpm), "A" port flow 100 L/min (26 USgpm), "B" port flow
For K(A)DG5V-8 valves:		
33C250N170	33C	250 L/min (66 USgpm), "A" port flow 170 L/min (45 USgpm), "B" port flow
133C250N170	133C	250 L/min (66 USgpm), "A" port flow 170 L/min (45 USgpm), "B" port flow
For KDG5V-10 valves:		
2C310N550	2C	310 L/min (82 USgpm), "A" port flow 550 L/min (145 USgpm), "B" port flow
2C550N310	2C	550 L/min (145 USgpm), "A" port flow 310 L/min (82 USgpm), "B" port flow
33C310N550	33C	310 L/min (82 USgpm), "A" port flow 550 L/min (145 USgpm), "B" port flow
33C550N310	33C	550 L/min (145 USgpm), "A" port flow 310 L/min (82 USgpm), "B" port flow

Operating Data

Data is typical:
 With fluid at 36 cSt (168 SUS) and 50°C (122°F).
 Using recommended Vickers amplifier to drive KDG5V models.

KDG5V valves

Installation and Start-up Guidelines	ML-B-9046
Max. solenoid current Coil type:	
U-G	3.5A
U-GP	3.0A
U-H	1.6A
U-HA	0.94A
U-HR	0.8A
Coil resistance Coil type:	At 20°C (68°F) Max. operating
U-G	1.65Ω 2.66Ω
U-GP	2.0Ω 3.1Ω
U-H	7.3 Ω 11.3 Ω
U-HA	22.1Ω 34.6Ω
U-HR	19.1Ω 29.9Ω
Coil inductance measured at 1000 Hz and 150 mV Coil type:	
U-G	4 mH
U-GP	6 mH
U-H	19 mH
U-HA	55 mH
U-HR	51 mH
Hysteresis Size 5/7/8 Size 10	± 4% of rated max. flow Size 5/7/8 <6% of rated max. flow Size 10
Repeatability: Size 5/7/8 Size 10	<3% 8%
Relative duty factor	Continuous rating (ED = 100%)
Type of electrical protection, with electrical plugs fitted correctly	IEC 144 Class IP65
Electrical connection	ISO 4400 (DIN 43650)
Recommended drive amplifier	Vickers Eurocard type: EEA-PAM-520-A-14 (one ramp), or EEA-PAM-523-A-32 (two ramps)

KADG5V-5/7/8 Valves with Integral Amplifiers

Power supply	24V DC (21V to 36V including 10% peak-to-peak max. ripple) max. current 3A
Command signal Input impedance	± 10V DC 47 kΩ
7-pin plug connector Pin connections: A B C D E F G	Power supply +ve Power 0V Signal 0V +ve voltage command signal -ve voltage command signal Monitor output Protective ground
Electro-magnetic compatibility (EMC): Emission (10 v/m) Immunity (10 v/m)	EN 50081-2 EN 50082-2
Gain adjustment	25 to 125%
Factory set adjustments	Deadband, gain, dither and offset
Monitor point signal Output impedance	0,5V per amp solenoid current 10 kΩ
Power stage PWM frequency	2 kHz nominal
Reproducibility, valve-to-valve (at factory settings): Flow gain at 100% command signal	<3% of rated flow
Protection: Electrical Mechanical	Reverse polarity protected IEC 144, Class IP65
Relative humidity	65 to 85% at 20 to 70°C (68 to 158°F)
Supporting products: Auxiliary electronic modules (DIN-rail mounting): EHA-CON-201-A-2* signal converter EHD-DSG-201-A-1* command signal generator EHA-RMP-201-A-2* ramp generator EHA-PID-201-A-2* PID controller	

Performance Characteristics

Data is typical with fluid at 36 cSt (168 SUS) and 50°C (122°F), using Vickers recommended amplifier to drive KDG5V models.

Minimum Pressure

For full flow performance pilot pressure ≥ 45 bar (650 psi), i.e.:
 Pressure at port P for internal pilot supply ("X" or omit in model code).
 Pressure at port X for external pilot supply ("E" or "EX" in model code).

Pilot Drain Application Notes

External pilot drain is to recommended configuration.
 Internal pilot drain is possible where a stable "T" port pressure, not exceeding 8 bar (116 psi), can be guaranteed.



Any pressure surges at the "T" port (drain) will cause the main spool to move and change the valve output. This possibility is eliminated by the use of an external drain.

Maximum Pressures, bar (psi)

For models without integral pilot pressure reducer

Model	Pilot Pressure Source	Model code <input type="checkbox"/>	P,A,B	Ports		
				T	X	Y•
KDG5V-5	External	E	315 (4500)	210 (3000)	200 (2900)	8 (116)
	Internal	Omit	200● (2900)	210 (3000)	◆	8 (116)
KDG5V-7/8	External	E	350 (5000)	350 (5000)	200 (2900)	8 (116)
	Internal	Omit	200● (2900)	350 (5000)	◆	8 (116)
KDG5V-10	External	E	350 (5000)	350 (5000)	210 (3000)	8 (116)
	Internal	Omit	200 (2900)	350* (5000)	◆	8 (116)

For models with integral pilot pressure reducer

KDG5V-5	External	EX	315 (4500)	210 (3000)	315 (4500)	8 (116)
	Internal	X	315 (4500)	210 (3000)	◆	8 (116)
KDG5V-7/8	External	EX	350 (5000)	350 (5000)	315 (4500)	8 (116)
	Internal	X	315● (4500)	350 (5000)	◆	8 (116)
KDG5V-10	External	EX	350 (5000)	350* (5000)	315 (4500)	8 (116)
	Internal	X	315 (4500)	350 (5000)	◆	8 (116)

- ◆ When using internal pilot pressure, port X should be plugged at the subplate or manifold face (e.g. manifold not drilled for connection to port X).
- The maximum pressure for ports A and B is: 315 bar (4500 psi) for size 5; 350 bar (5000 psi) for sizes 7, 8 and 10.
- See "Pilot Drain Application" note.
- *—Pilot must be externally drained, otherwise "Y" port pressure applies.

Performance Curves

Flow Gain

Flow gain curves at stated values of total valve pressure drop, for flow P-A-B-T, or P-B-A-T.

KDG5V-5-2C90N

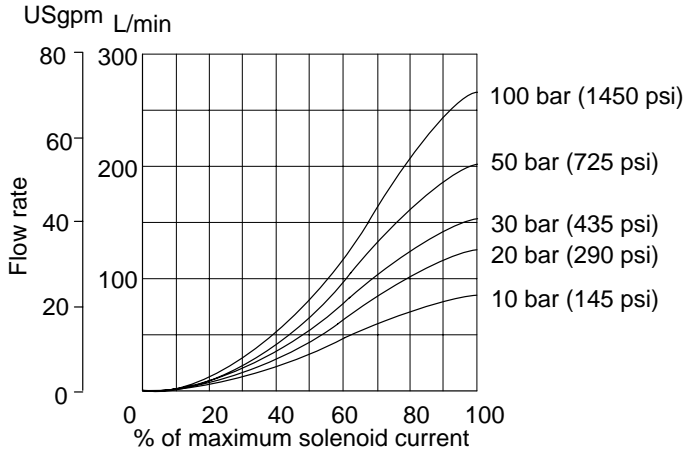

KDG5V-5-33C80N

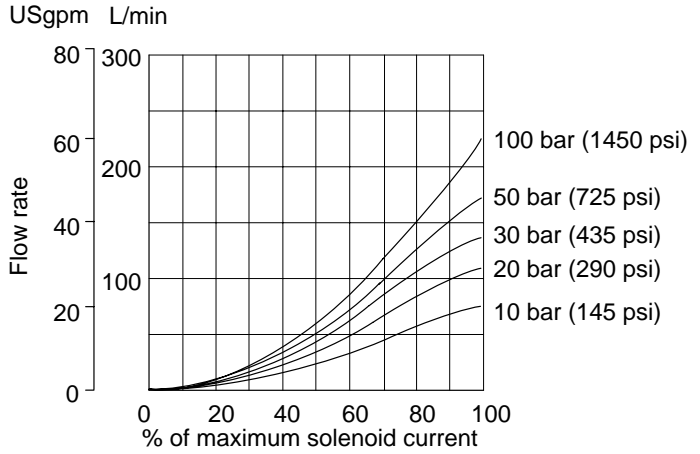

KDG5V-7-2C180N

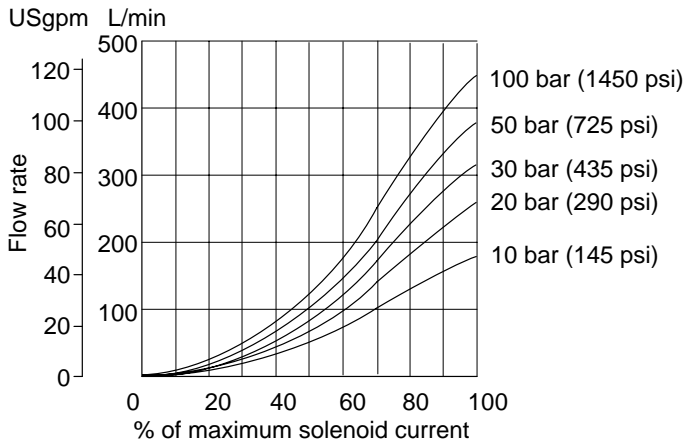

KDG5V-7-33C170N

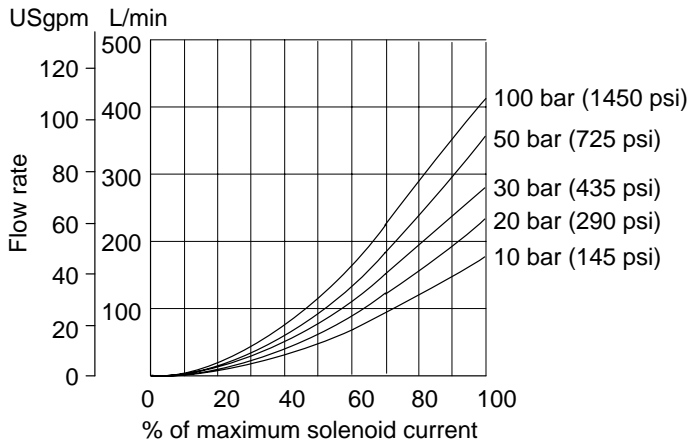

KDG5V-8-2C280N

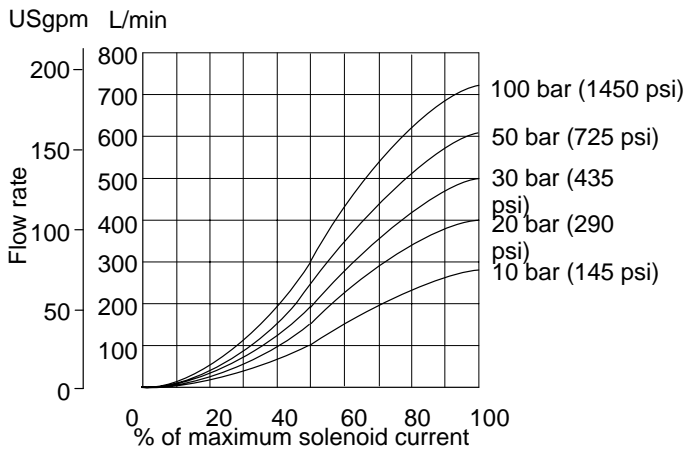

KDG5V-8-33C270N

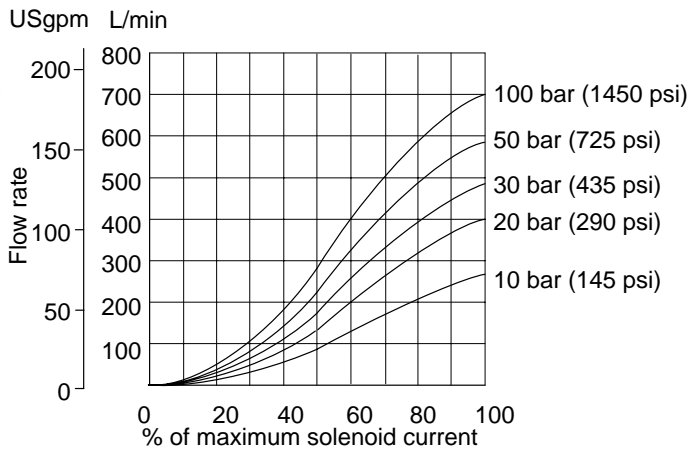

KDG5V-10

Power Capacity Envelopes
Flow through P-A-B-T or P-B-A-T

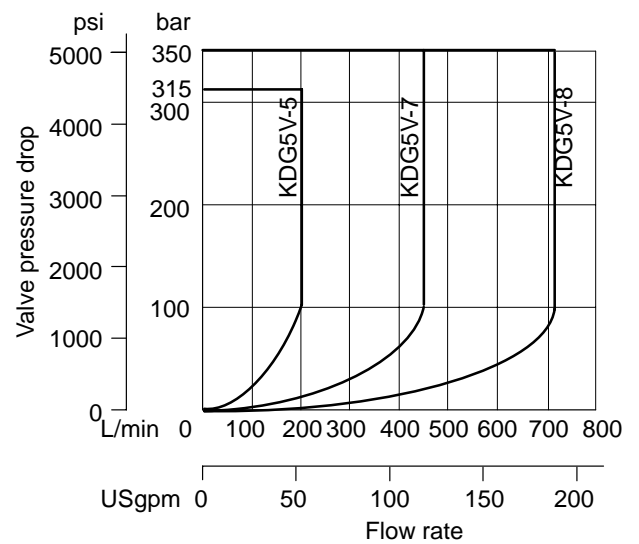
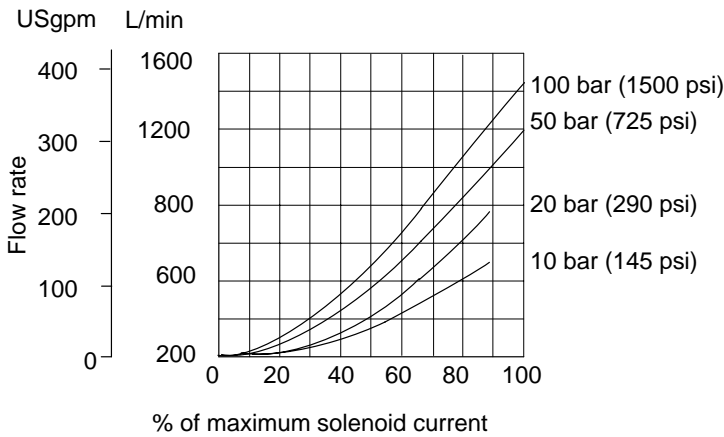

Subject to maximum pressure limitations according to model type; see "Maximum Pressures".

Typical Step Response Test conditions: No pressure reducer module Flow P-A-B-T Total valve $\Delta p = 10$ bar (145 psi) Pilot pressure = 50 bar (725 psi) "Response" = Time, from step response signal, until output reaches 90% of step change value	Input signal step change	Spool response times (ms)			
		KDG5V-5	KDG5V-7	KDG5V-8	KDG5V-10
	0 to 100%	48	61	80	206
	100% to 0	38	43	40	182
	10% to 90%	42	58	66	
	90% to 10%	50	58	54	
	25% to 75%	30	47	49	
	75% to 25%	50	58	66	
	90% to 90%	70	87	98	
	0% to 75%				170
	75% to 0%				175
	0% to 50%				160
	50% to 0%				160
	0% to 25%				124
	25% to 0%				124

Pilot flow required to achieve above response times:

KDG5V-5	KDG5V-7	KDG5V-8	KDG5V-10
2,7 L/min (0.7 USgpm)	4,2 L/min (1.1 USgpm)	7,5 L/min (2.0 USgpm)	18,75 L/min (5.0 USgpm)

Installation Dimensions

KDG5V Models with “EX” or “X”
 (With integral pilot pressure reducer)
 The illustration is correct for KDG5V-7 valves
 Dimensions are shown in mm (inches)

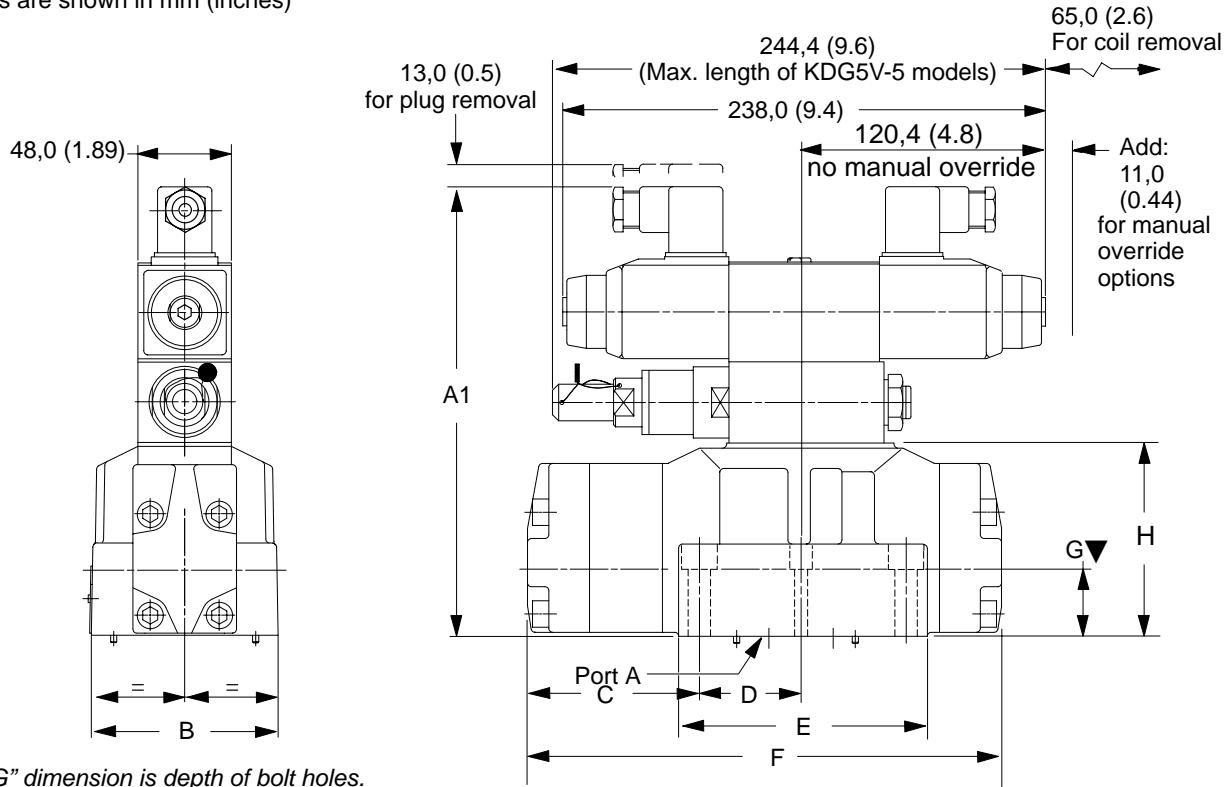

▼ “G” dimension is depth of bolt holes.
 (On KDG5V-7 only, this coincides with the height to the center line of the main-stage spool).

KDG5V Models with “E” or No Symbol
 (Without integral pilot pressure reducer)

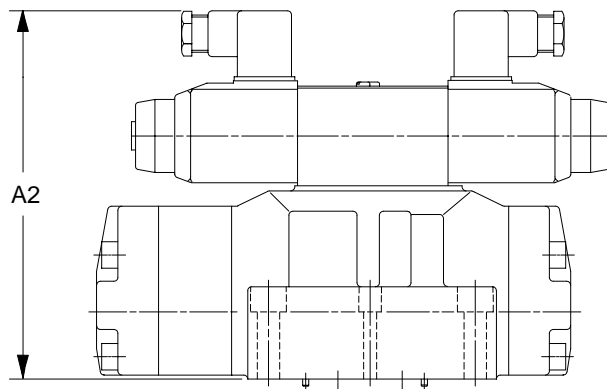

Model	A1	A2	B	C	D	E	F	G	H
KDG5V-5	215,0 (8.47)	175,0 (6.9)	70, (2.77)	94,4 (3.72)	27,0 (1.06)	98, (3.86)	217,0 (8.54)	30,0 (1.18)	87,3 (3.4)
KDG5V-7	223,0 (8.8)	183,0 (7.2)	92,8 (3.65)	83,3 (3.3)	50,0 (1.97)	124,0 (4.88)	232,0 (9.14)	33,0 (1.3)	95,1 (3.7)
KDG5V-8	255,0 (10.1)	215,0 (8.47)	114,8 (4.52)	118,4 (4.66)	77,0 (3.03)	185,0 (7.28)	332,0 (13.1)	59,0 (2.32)	127,2 (5.0)

KADG5V-5/7/8 models fitted with integral amplifier

Metal plug 934939

Cable outside diameter 8,0 to 10,5 (0.31 to 0.41)
Must be used for full EMC protection. See also warning note on page B.32.

Plastic plug 694534

PG11. Cable maximum outside diameter 11,0 (0.43)

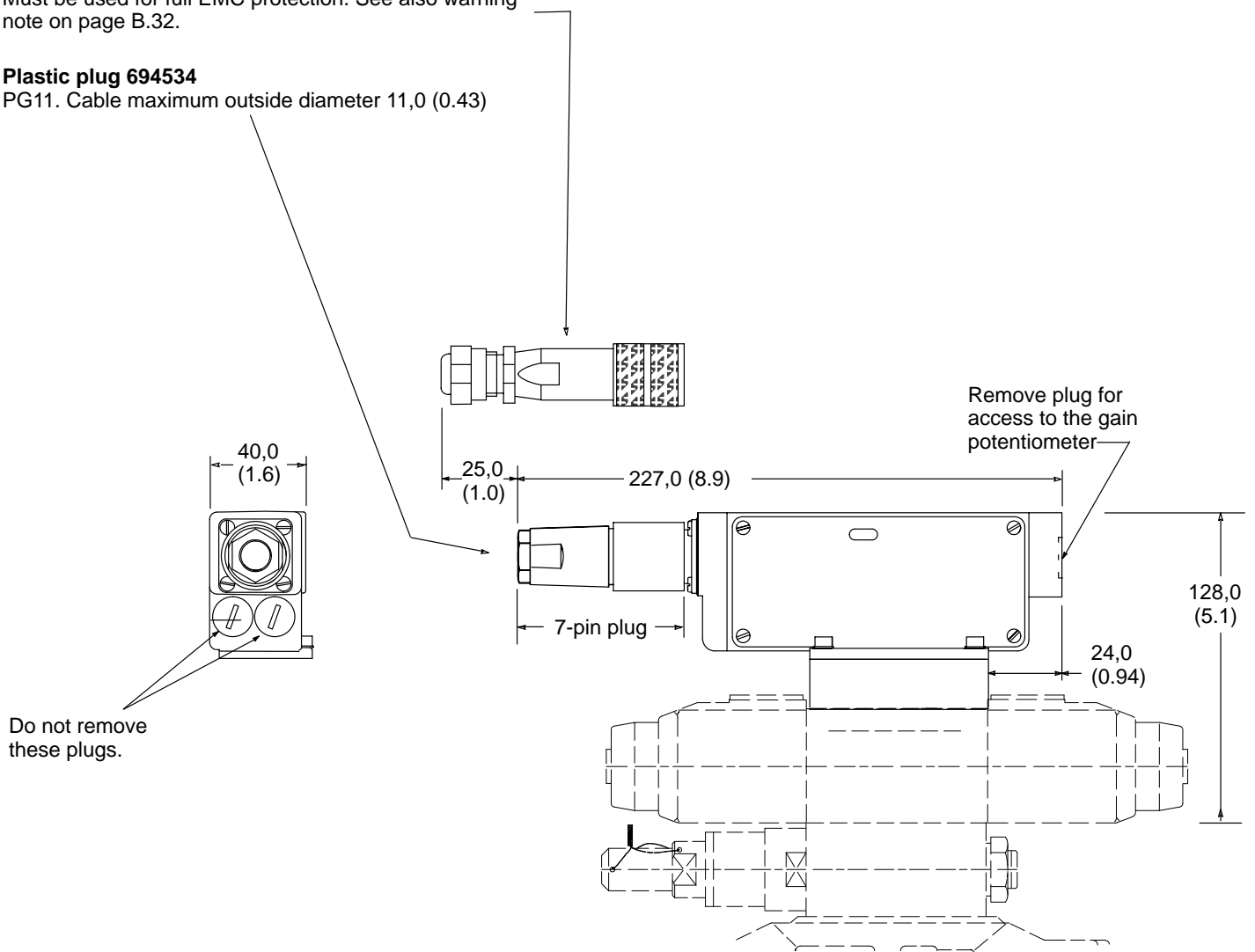

KDG5V-10 Models with "EX" or "X"
 (With integral pilot pressure reducer)
 Dimensions are shown in mm (inches)

3rd angle
 projection

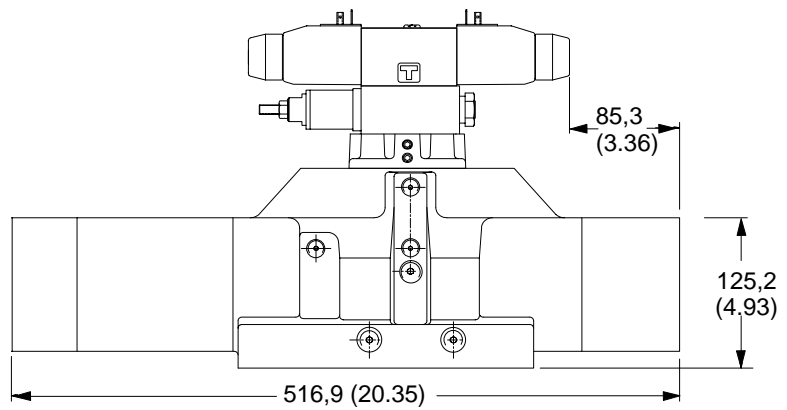
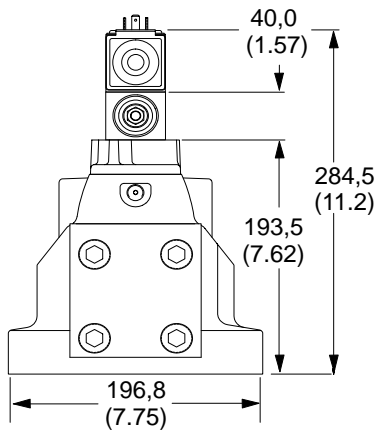
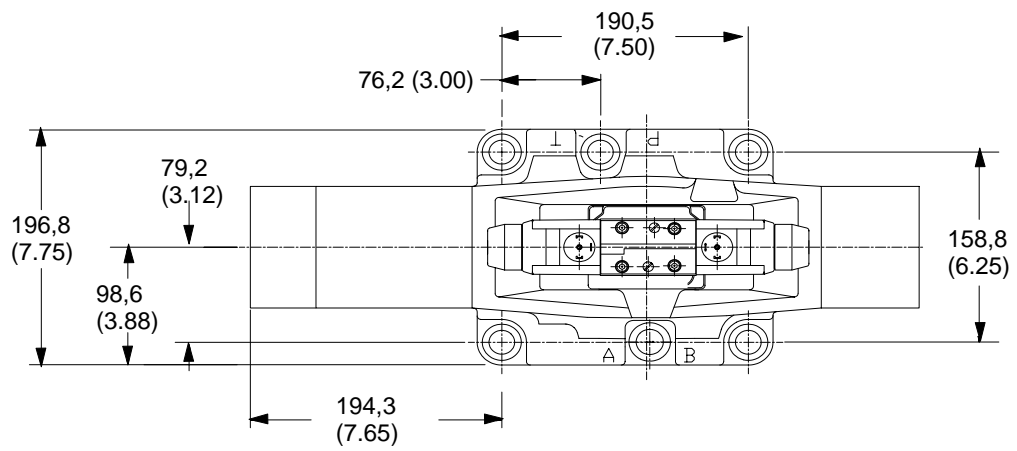
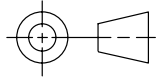

Pilot Supply and Drain Plugs

KDG5V-5 models

Viewed from port B end of main-stage

M5 plug, part no. 471119. Remove for internal pilot supply

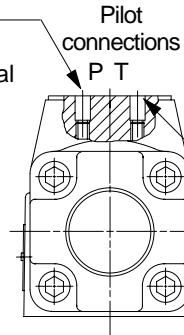

M5 plug, part no. 471119. Remove for internal pilot drain

KDG5V-7 models only*

Remove this plug for access to pilot drain plug

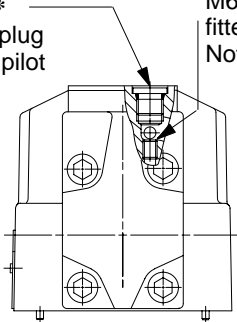

KDG5V-7 models only*

M6 x 8mm plug, part no. 471131: fitted for external pilot drain. Not fitted for internal pilot drain.

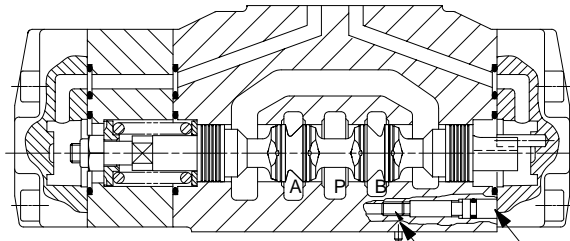

KDG5V-7 models only*

M6 x 8mm plug, part no. 471131: fitted for external pilot supply models; not fitted for internal pilot supply models. See "Model Code".

Size 7 only* M5 internal thread for removal of closure plug

* Internal plug shown, for external pilot supply (via port X). For internal pilot supply (from port P) plug is not fitted. Port X should be blocked at mounting interface, or otherwise plugged at subplate of manifold block. See "Model Code".

KDG5V-8 models

Section through port P of main-stage

M5 plug, part no. 471119. Remove for internal pilot drain

1/16" NPT plug, part no. 113000. Remove for internal pilot supply

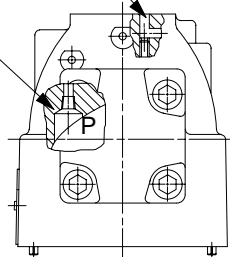

KDG5V-10 models

plug, part no. 7074. Remove for internal pilot drain

plug, part no. 30560 for internal pilot drain, part no. 7074 for external pilot drain.

plug, part no. 30560. Remove for internal pilot drain

Views on Mounting Faces

All O-seals supplied

KDG5V-5 mounting face

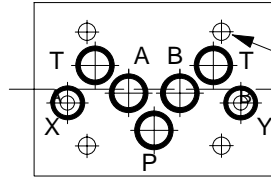

4 holes for mounting bolts
 $\varnothing 7,02 (0.27\varnothing)$ spotfaced to
 $\varnothing 11,0 (0.43\varnothing)$

KDG5V-7 mounting face

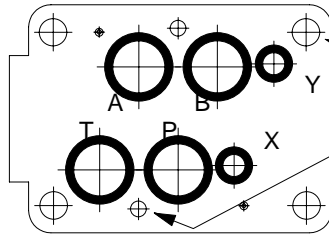

6 holes for mounting bolts
 4 x $\varnothing 11,0 (0.43\varnothing)$ c'bored
 $\varnothing 17,5 (0.68\varnothing)$
 2 x $\varnothing 6,4 (0.25\varnothing)$ c'bored
 $\varnothing 11,0 (0.43\text{ dia})$

KDG5V-8 mounting face

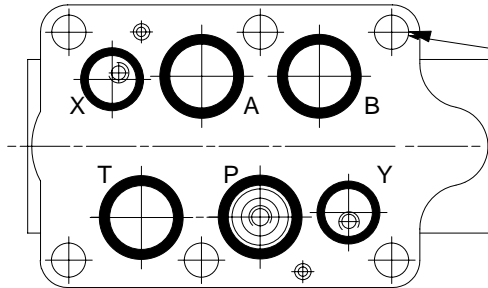

6 holes for mounting bolts
 $\varnothing 13,5 (0.53\varnothing)$
 spotfaced to
 $\varnothing 20,0 (0.78\varnothing)$



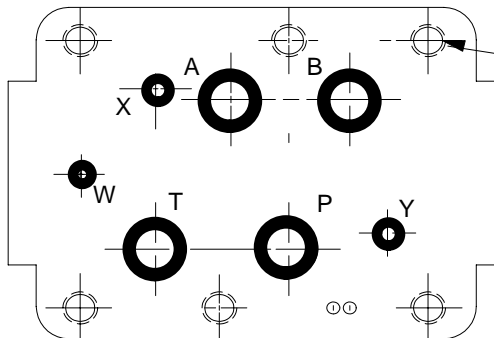



KDG5V-10 mounting face

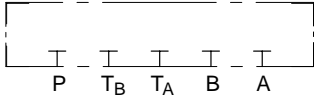

6 holes for mounting bolts

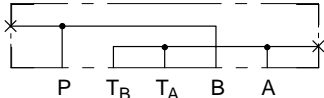
Subplates, Connection Plates and Mounting Surfaces

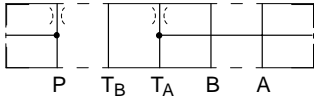
Size 05

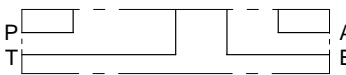
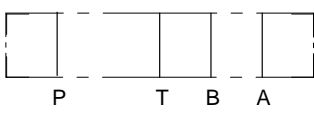
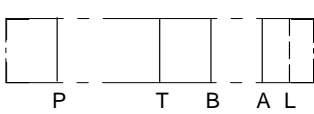
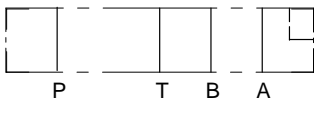
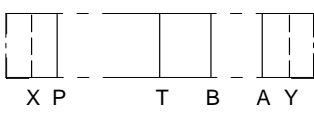
Description and Mass kg (lb)	Functional Symbol	Model Code	Max. Pressure
Blanking plate Cast iron 2,9 (6.4)		DGMA-5-B-1*	315 bar (4500 psi)
Crossover plate P-A; B-T Cast iron 2,9 (6.4)		DGMA-5-C1-1*	315 bar (4500 psi)
Crossover plate P-B; A-T Cast iron 2,9 (6.4)		DGMA-5-C2-1*	315 bar (4500 psi)
Tapping plate, ports A and B Cast iron 0,5 (1.1)		DGMA-5-T1-1*-B▲	315 bar (4500 psi)
Tapping plate, ports P and T Cast iron 0,5 (1.1)		DGMA-5-T2-1*-B▲	315 bar (4500 psi)
Tapping plate, ports P, A and B Cast iron 0,5 (1.1)		DGMA-5-T3-1*-B▲	315 bar (4500 psi)
Adaptor plate for pilot ports X and Y Cast iron 1,4 (3.1)		DGAM-5-1*-R▲ DGAM-5-1*-S▲	210 bar (3000 psi)
Single-station subplate; side ports P, T, A, B Cast iron 2,0 (4.4)		DGSME-01-2*-T8▲	210 bar (3000 psi)
Single-station subplate; rear ports P, T, A, B Cast iron 2,0 (4.4)		DGSM-01-2*-T8▲ EDGSM-01-1*-R▲ EDGSM-01X-1*-R▲ EDGSM-01Y-1*-R▲	210 bar (3000 psi) 280 bar (4000 psi)
Single-station subplate; rear ports P, T, A, B; and port L (side or rear) Cast iron 1,3 (2.9)	 	KDGSM-5-676805-2* (SAE/UNF ports) KDGSMS-5-615225-1* (1/2" BSPF ports) KDGSMS-5-615226-1* (3/4" BSPF ports)	210 bar (3000 psi) 315 bar (4500 psi)
Single-station subplate; rear ports P, T, A, B plus X and Y Cast iron 2,0 (4.4)		EKDGSMS-01Y-1*-R▲ EDGSM-03-1*-R▲ EDGSM-03X-1*-R▲ EDGSM-03X-1*-S▲	280 bar (4000 psi) 210 bar (3000 psi)

*Design number subject to change. No change of installation dimensions for design numbers 10 to 19 or 21 to 29 inclusive.

▲ "S" or "T8" suffix = SAE/UNC ports and/or UNC fixing bolt tappings and/or orifice plugs as appropriate. "R" or "B" = ISO 228 (BSPF) ports and/or metric fixing bolt tappings and/or orifice plugs as appropriate.

Sizes 07 and 08

Description and Mass kg (lb)	Functional Symbol	Model Code	Max. Pressure
Single-station subplate			
Cast iron 3,8 (8.4)		DGSM-04	210 bar (3000 psi)
Cast iron 3,8 (8.4)		EDGVM-7X	350 bar (5000 psi)
Cast iron 6,1 (13.4)		EDGVM-7Y/7Z	350 bar (5000 psi)
Cast iron 5,0 (11)		DGSM-8	210 bar (3000 psi)
Cast iron 5,0 (11)		EDGVM-8X	350 bar (5000 psi)
Cast iron 13 (28.6)		EDGVM-8Y/8Z	350 bar (5000 psi)

General Description

When a subplate is not used, a machined pad must be provided for valve mounting. Pad must be flat within 0,127 mm (.0005 inch) and smooth within 1,6 μm (63 microinch). Mounting bolts, when provided by customer, should be SAE grade 7 or better.

Dimensional Tolerances

Dimensional tolerance on interface drawings is $\pm 0,2$ mm (± 0.008 ") except where otherwise stated.

ISO 4401 specifies inch conversion to ± 0.01 ".

Conversion from Metric

ISO 4401 gives dimensions in mm. Inch conversions are accurate to 0.01" unless otherwise stated.

Mounting Bolt Tappings

ISO 4401 gives metric thread tappings. Alternate UNC tappings are Vickers

recommendations that allow these plates and associated valves to be used up to their maximum pressures, when using Vickers recommended bolt kits, or bolts of an equivalent strength (see page B.38). It is recommended that Customer's own manifold blocks for UNC bolts should be tapped to the minimum depths given in the footnotes.

Installation Dimensions

DGMA-5-B-1* Blanking Plate

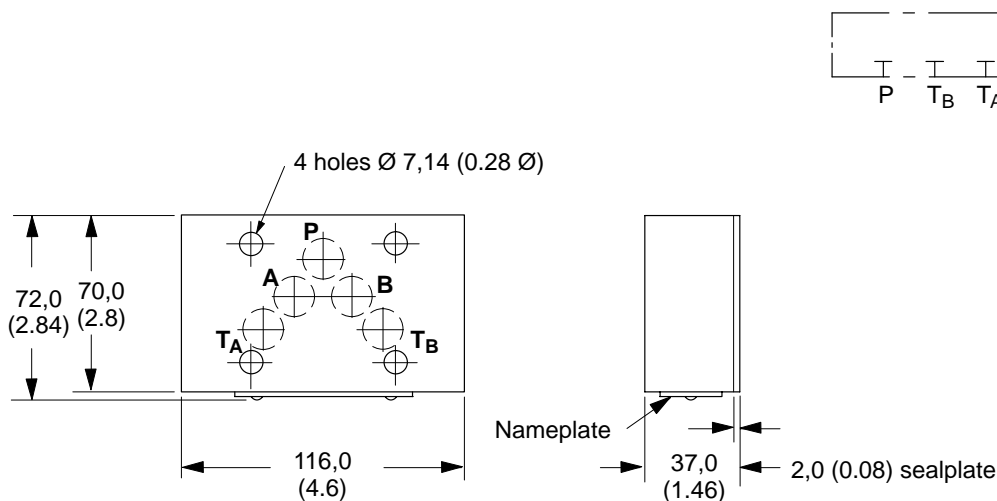

DGMA-5-C*-1*
Crossover Plate

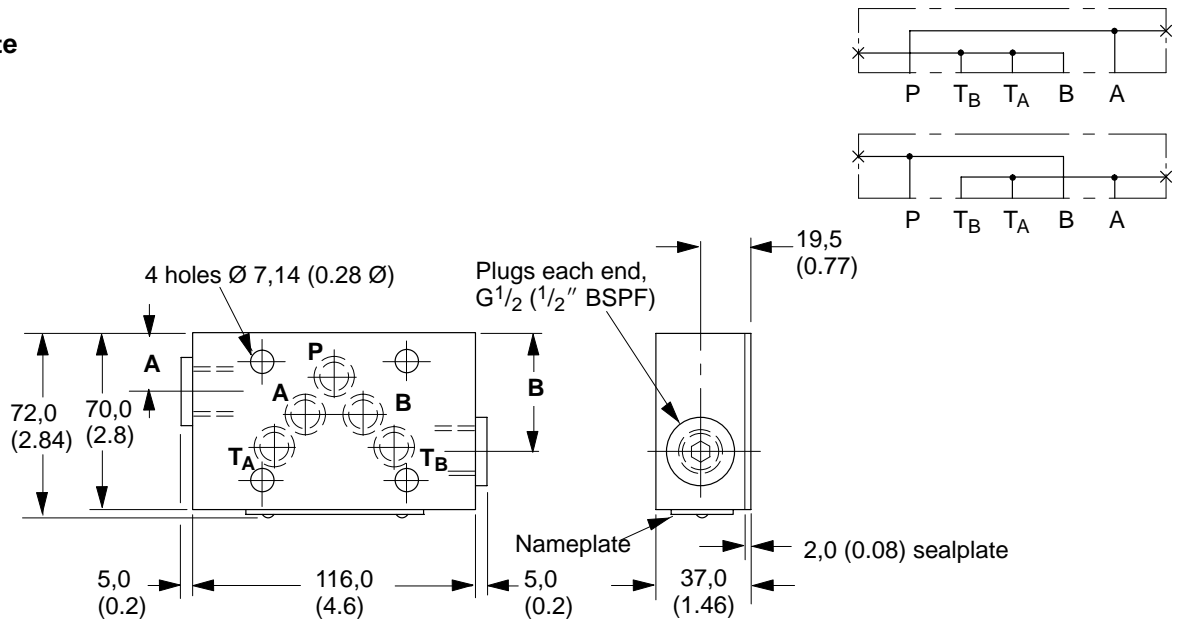

Model	Dimension A	Dimension B
DGMA-5-C1-1*	25,0 (1.0)	40,0 (1.6)
DGMA-5-C2-1*	40,0 (1.6)	25,0 (1.0)

DGMA-5-T1-1*-B
Tapping Plate
Ports A and B

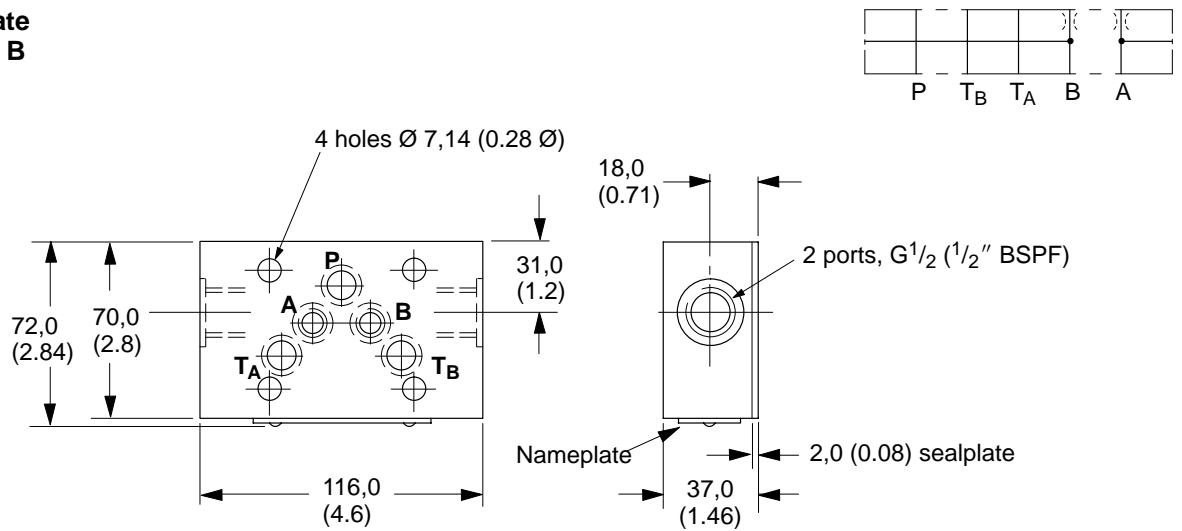

Ports A and B are tapped M12 x 14 (0.55) deep (e.g. for orifice plugs) on opposite face to sealplate.

DGMA-5-T2-1*-B
Tapping Plate
Ports P and T

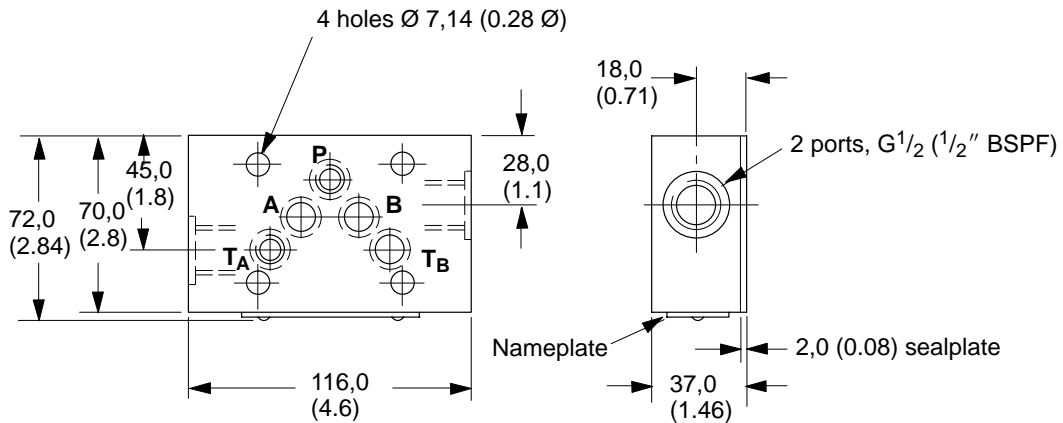
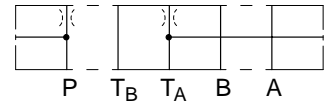

Ports P and T_A are tapped M12 x 14 (0.55) deep (e.g. for orifice plugs) on opposite face to sealplate.

DGMA-5-T3-1*-B
Tapping Plate
Ports P, A and B

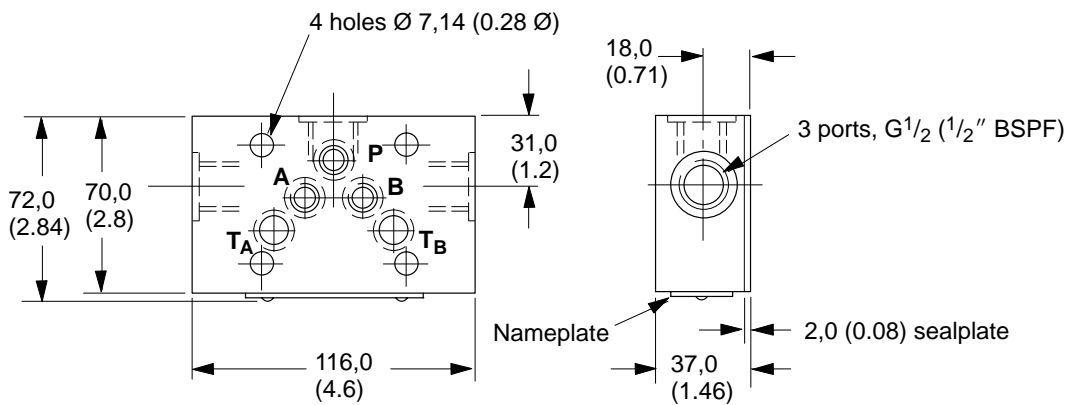

Ports P, A and B are tapped M12 x 14 (0.55) deep (e.g. for orifice plugs) on opposite face to sealplate.

**DGAM-5-1*-* , X and Y
Port Adaptor Plates**

Provides for external connections to additional pilot ports X and Y when these ports are not present in subplate/manifold block. Typically used for two-stage directional and proportional valves.

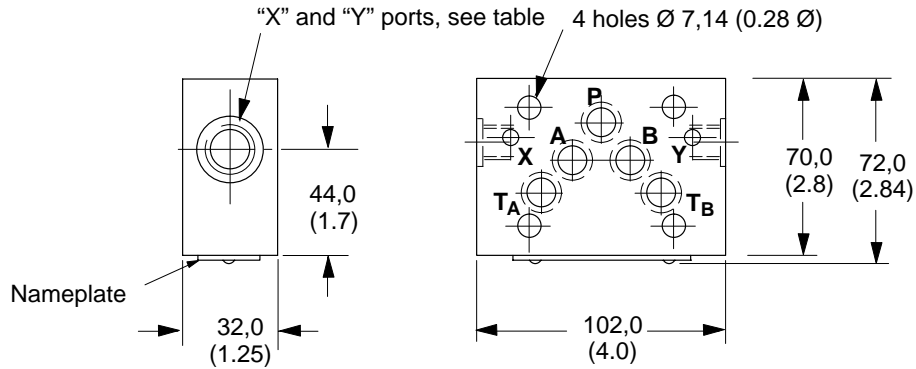
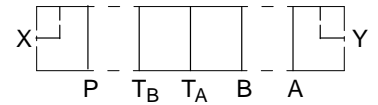

Model	"X" and "Y" port thread
DGAM-5-1*-R	G1/4 (1/4" BSPF x 11,0 (0.43) full thread depth
DGAM-5-1*-S	9/16"-18UNF x 12,7 (0.5) full thread depth

**DGSME-01-2*-T8
Subplate with Side Ports P, T, A, B
Maximum Pressure 210 bar (3000 psi)**

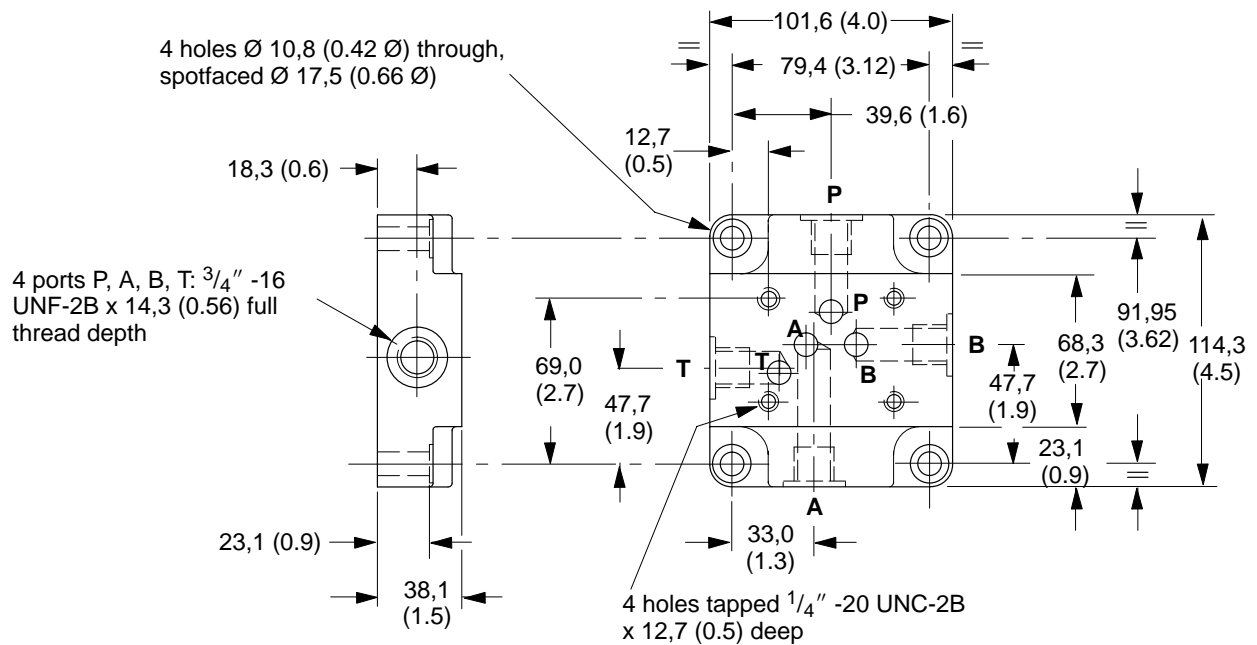
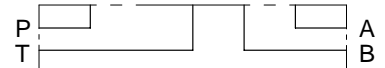

DGSM-01-2*-T8
KDGSMS-5-676805-2*
 (with rear port L)
 Subplates with Rear Ports P, T, A, B
 Maximum Pressure 210 bar (3000 psi)

EDGSM-01-1*-R
EDGSM-01X-1*-R
EDGSM-01Y-1*-R
EKDGSMS-01Y-1*-R
 (with side port L)
 Maximum Pressure 280 bar (4000 psi)

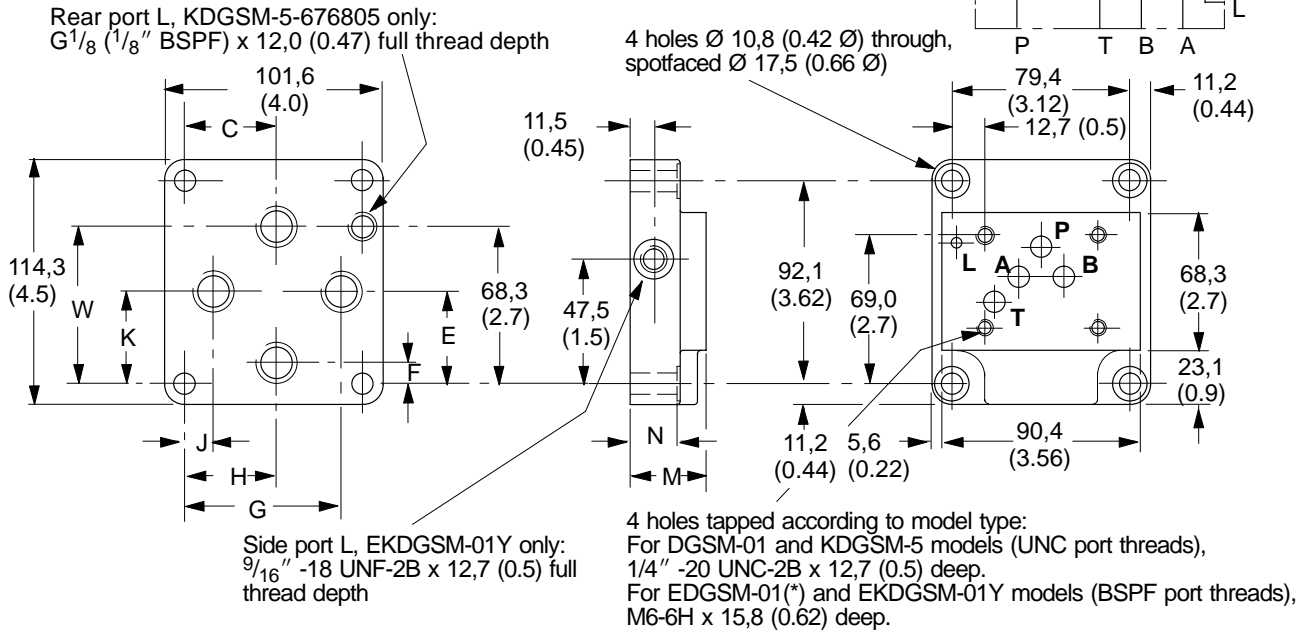

Ports P, T, A, B Threads

Model	Port thread
210 bar (3000 psi)	
DGSM-01-2*-T8	$\frac{3}{4}$ " -16 UNF-2B x 14,0 (0.56) full thread depth
KDGSMS-5-676805-2*	

Ports P, T, A, B Threads

Model	Port thread
280 bar (4000 psi)	
EDGSM-01-1*-R	$G\frac{1}{4}$ ($\frac{1}{4}$ " BSPF) x 12,2 (0.48) full thread depth
EDGSM-01X-1*-R	$G\frac{3}{8}$ ($\frac{3}{8}$ " BSPF) x 12,2 (0.48) full thread depth
EDGSM-01Y-1*-R	$G\frac{1}{2}$ ($\frac{1}{2}$ " BSPF) x 15,0 (0.59) full thread depth
EKDGSMS-01Y-1*-R	

Model	C	E	F	G	H	J	K	M	N	W
210 bar (3000 psi)										
DGSM-01-2*-T8	45,2	42,1	19,0	68,3	45,2	23,8	42,1	31,8	23,9	57,1
KDGSMS-5-676805-2*	(1.78)	(1.7)	(0.75)	(2.69)	(1.78)	(0.94)	(1.7)	(1.25)	(0.94)	(2.25)
280 bar (4000 psi)										
EDGSM-01-1*-R	39,7	38,1	13,5	65,5	41,7	10,3	40,9	31,8	23,9	62,7
EDGSM-01X-1*-R	(1.56)	(1.5)	(0.53)	(2.58)	(1.64)	(0.41)	(1.61)	(1.25)	(0.94)	(2.47)
EDGSM-01Y-1*-R	39,7	40,5	13,5	67,5	39,7	12,7	40,5	31,8	23,9	68,6
EKDGSMS-01Y-1*-R	(1.56)	(1.59)	(0.53)	(2.66)	(1.56)	(0.5)	(1.59)	(1.25)	(0.94)	(2.7)
EDGSM-01Y-1*-R	39,7	40,5	9,9	70,6	39,7	10,7	40,5	31,8	28,6	72,6
EKDGSMS-01Y-1*-R	(1.56)	(1.59)	(0.39)	(2.78)	(1.56)	(0.42)	(1.59)	(1.25)	(1.13)	(2.86)
EKDGSMS-01Y-1*-R	39,7	40,5	9,9	70,6	39,7	10,7	40,5	36,5	28,6	72,6
EKDGSMS-01Y-1*-R	(1.56)	(1.59)	(0.39)	(2.78)	(1.56)	(0.42)	(1.59)	(1.44)	(1.13)	(2.86)

KDGSM-5-615225-1*

KDGSM-5-615226-1

Subplates with Rear Ports P, T, A, B, L

Maximum Pressure 315 bar (4500 psi)

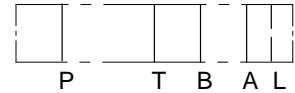

Recommended panel cut-out to clear fittings, Ø 108,0 (4.25 Ø)

Port L, G¹/₄ (1/4" BSPF) x 12,0 (0.47), spotfaced to Ø 24,0 (0.94 Ø)

Port L, Ø 4,0 (0.16 Ø)

4 holes Ø 10,5 (0.41 Ø)

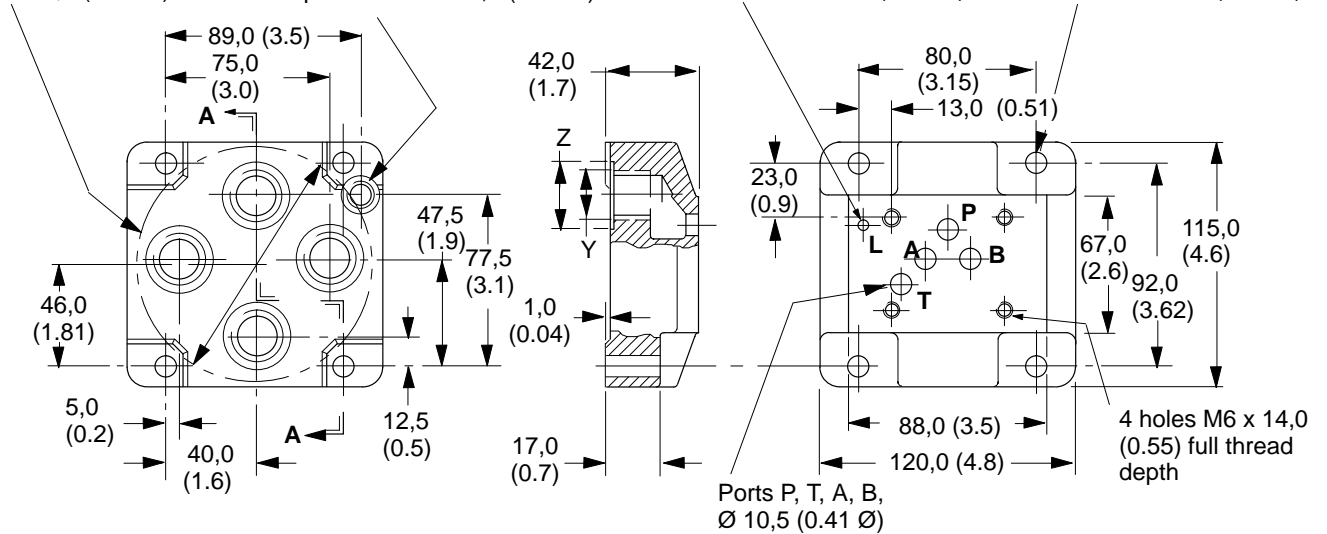

Part Section A-A

Ports P, T, A, B

Model	Y thread	Z diameter
KDGSM-5-615225-1*	G ¹ / ₂ (1/2" BSPF) x 14,0 (0.55) full thread depth	30,0 (1.18)
KDGSM-5-615226-1*	G ³ / ₄ (3/4" BSPF) x 16,0 (0.63) full thread depth	33,0 (1.3)

EDGSM-03-1*-R
EDGSM-03X-1*-R
EDGSM-03X-1*-S

Subplates with Rear Ports P, T, A, B, X, Y
Maximum Pressure 210 bar (3000 psi)

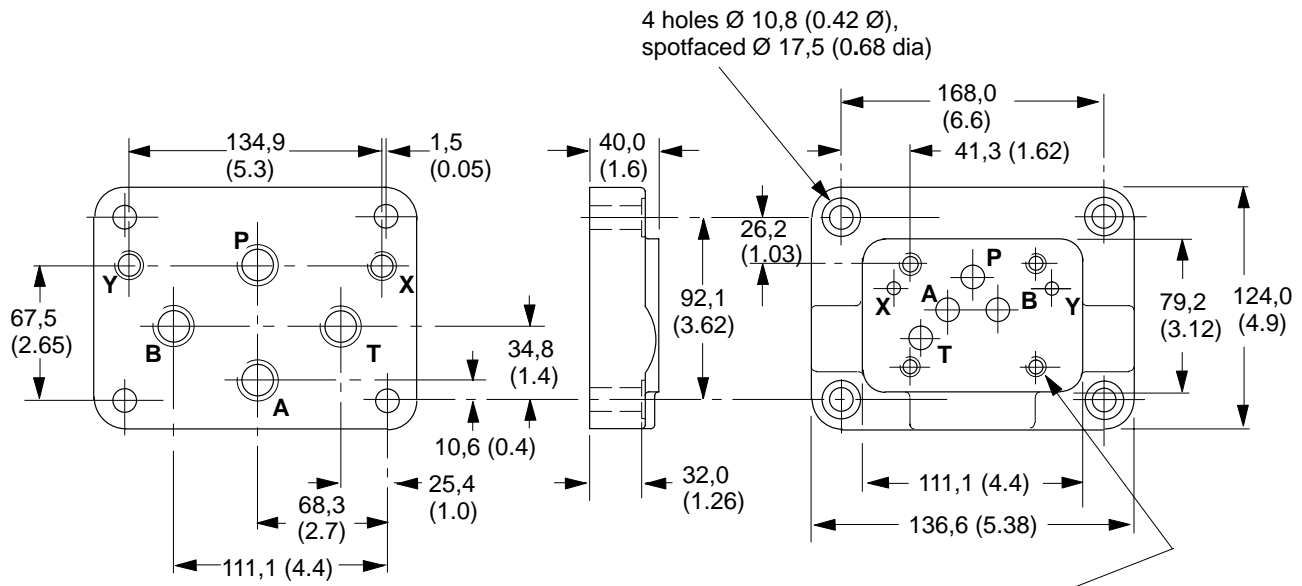
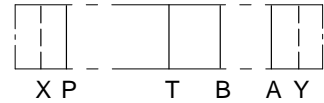

4 holes tapped according to model type:
 For EDGSM-03(X)-1*-R models (BSPF ports):
 M6-6H x 16,0 (0.63) full thread depth
 For EDGSM-03X-1*-S models (UNC ports):
 1/4"-20 UNC-2B x 16,0 (0.63) full thread depth

Port Threads

Model	Ports P, T, A, B	Ports X, Y
EDGSM-03-1*-R EDGSM-03X-1*-R	G ¹ / ₂ (1/2" BSPF) x 14,0 (0.55) full thread depth	G ¹ / ₄ (1/4" BSPF) x 12,2 (0.48) full thread depth
EDGSM-03X-1*-S	1 1/16"-12 UN-2B x 16,0 (0.63) full thread depth	9/16"-18 UNF-2B x 12,7 (0.5) full thread depth

EDGVM-7Y-D-1*-R (BSPF port threads; metric mounting bolts)
EDGVM-7Z-D-1*-S (UNF/SAE port threads; UNC mounting bolts)
Single station subplates

For up to 350 bar (5000 psi) Maximum Pressure
 Dimensions in mm (inches)

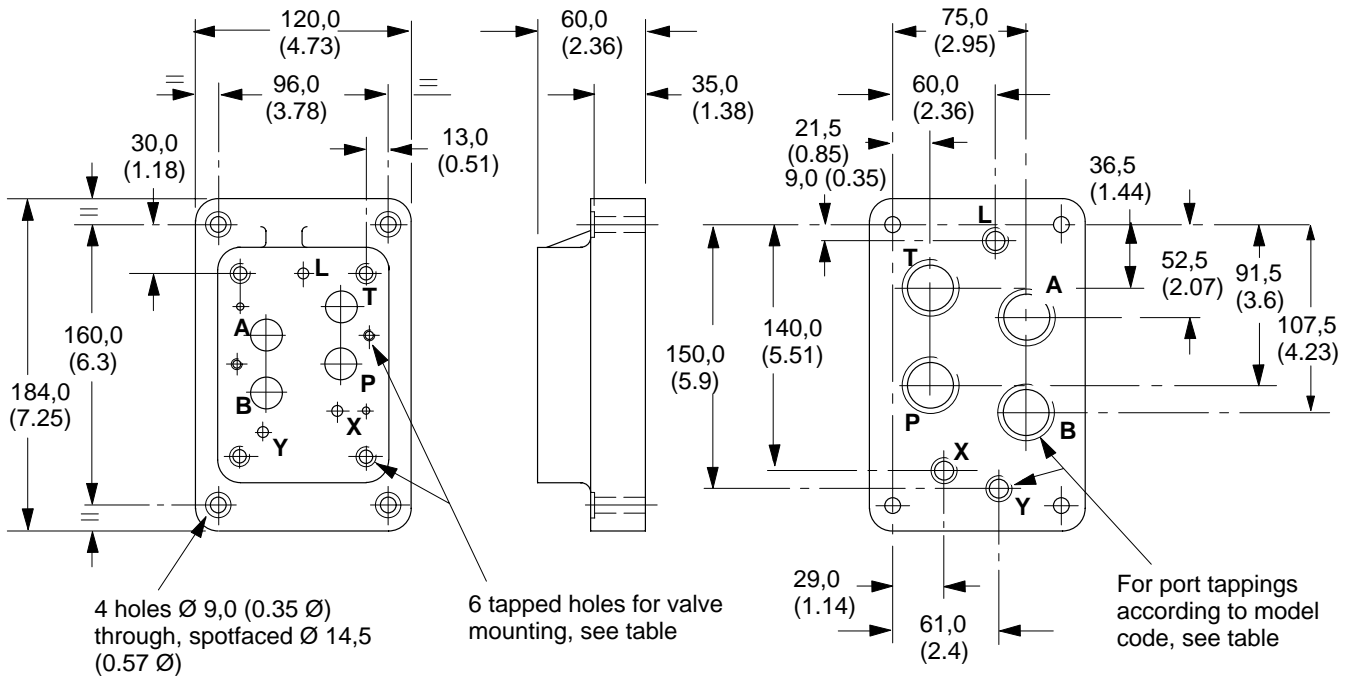
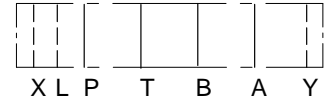

Port and Bolt Threads

Model	Ports P, T, A, B	Ports L, X, Y	Mounting bolt tapping
EDGVM-7Y-D-1*1-R	G1 (1" BSPF) x 19,0 (0.75) full thread depth	G1/4 (1/4" BSPF) x 12,0 (0.47) full thread depth	4 x M10 2 x M6
EDGVM-7Z-D-1*1-S	1 15/16" -12 UN 2B x 19,0 (0.75) full thread depth	3/16" -18 UNF 2B x 12,7 (0.5) full thread depth	4 x 3/8"-16 UNC 2 x 1/4"-20 UNC

DGSM-04-12S-2* (UNF/SAE port threads; UNC mounting bolts)
 For up to 210 bar (3000 psi) Maximum Pressure

EDGVM-7X-D-1*-R (BSPF port threads; metric mounting bolts)
 For up to 350 bar (5000 psi) Maximum Pressure
 Single station subplates

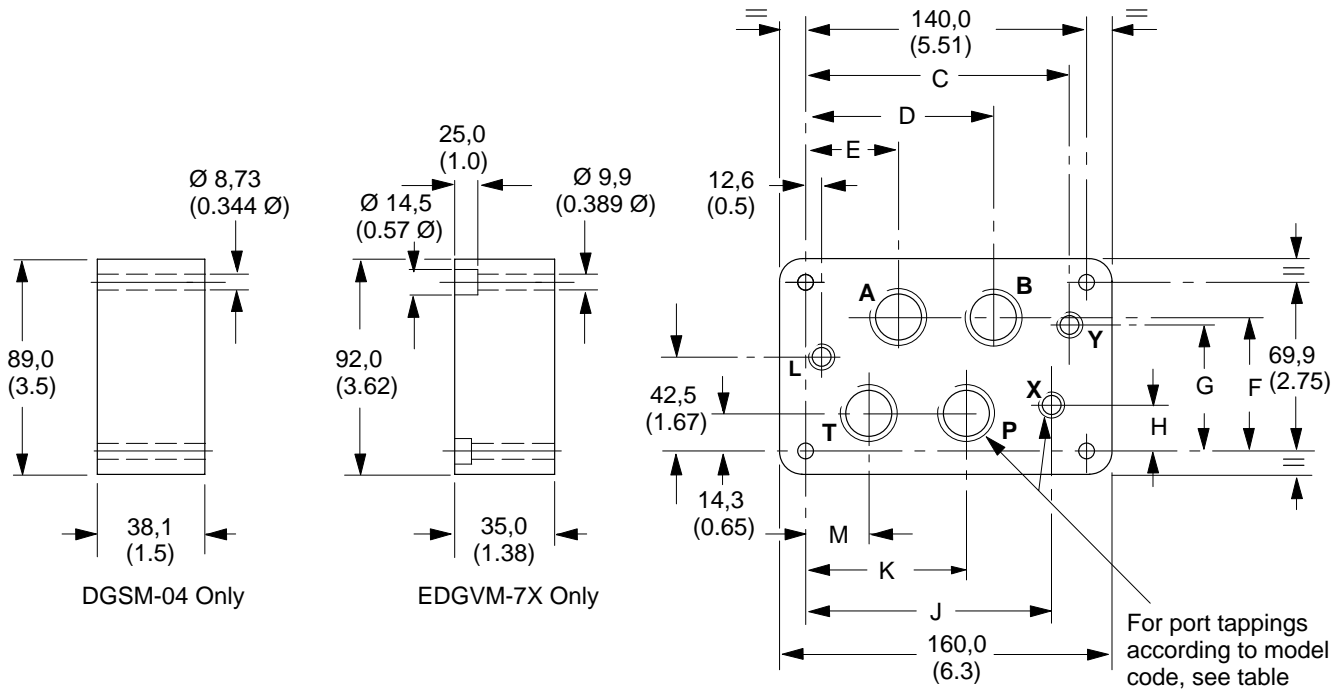
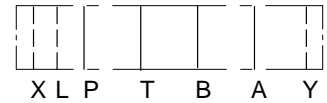

Port and Bolt Threads

Model	Ports P, T, A, B	Ports L, X, Y	Mounting bolt tapping
DGSM-04-12S-2*	1 1/16"-12 UNF-2B x 19,1 (0.75) full thread depth	9/16"-18 UNF-2B x 12,7 (0.5) full thread depth	4 x 3/8"-16 UNC 2 x 1/4"-20 UNC
EDGVM-7X-D-1*-R	G ^{3/4} (3/4" BSPF) x 16,0 (0.63) full thread depth	G1/4 (1/4" BSPF) x 12,0 (0.47) full thread depth	4 x M10 2 x M6

Dimensions

Model	C	D	E	F	G	H	J	K	M
DGSM-04-12S-2*	121,4 (4.78)	88,4 (3.48)	44,2 (1.74)	56,6 (2.23)	54,9 (2.16)	18,3 (0.72)	121,4 (4.78)	76,7 (3.02)	32,3 (1.27)
EDGVM-7X-D-1*-R	128,6 (5.06)	93,6 (3.68)	50,6 (1.99)	55,6 (2.19)	52,0 (2.05)	15,9 (0.63)	113,6 (4.47)	79,6 (3.13)	36,6 (1.44)

EDGVM-8(*)-1*-R (BSPF port threads;
metric mounting bolts)
EDGVM-8Y-1*-S (UNF/SAE port threads;
UNC mounting bolts)
For up to 350 bar (5000 psi) Maximum Pressure
Ports P, T, A, B, X, Y
Single station subplates

EDGVM-8(*)-D-1*-R (BSPF port threads;
metric mounting bolts)
EDGVM-8Y-D-1*-S (UNF/SAE port threads;
UNC mounting bolts)
Ports P, T, A, B, X, Y and L
Single station subplates

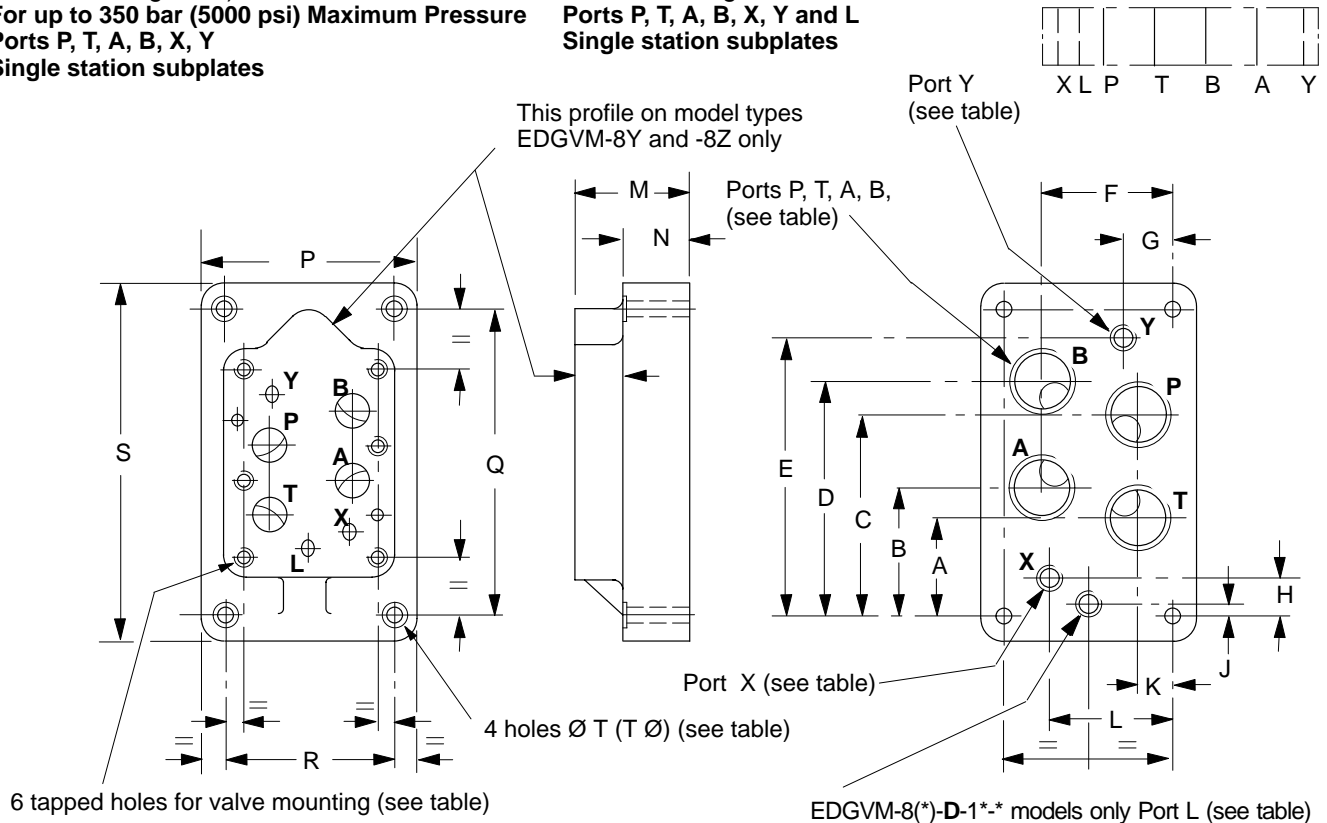

Port Threads, Bolt Tappings and Dimensions

Model	Ports P, A, B, T	Ports L, X, Y	Mounting bolt tappings	A	B	C	D	E	F
EDGVM-8(-D)-1*-R	G ³ / ₄ x 16 (0.63) deep (BSPF)	G ¹ / ₄ x 12,2 (0.48) deep (BSPF)	M12 x 25 (1.0) deep	54,8 (2.16)	78,6 (3.09)	102,4 (4.03)	126,2 (4.97)	160 (6.30)	74,6 (2.94)
EDGVM-8X(-D)-1*-R	G1 x 19 (0.74) deep (BSPF)	G ¹ / ₄ x12,2 (0.48) deep (BSPF)	M12 x 25 (1.0) deep	49,6 (1.95)	73,4 (2.89)	107,5 (4.23)	131,4 (5.17)	160 (6.30)	74,6 (2.94)
EDGVM-8Y(-D)-1*-R	G ¹ / ₄ x 21 (0.82) deep (BSPF)	G ¹ / ₄ x12,2 (0.48) deep (BSPF)	M12 x 25 (1.0) deep	50,5 (1.99)	74,2 (2.92)	128,0 (5.04)	151,8 (5.98)	185 (7.28)	103 (4.06)
EDGVM-8Y(-D)-1*-S	1 ⁵ / ₈ "-12 UN x 19,1 (0.75) deep	9/ ₁₆ "-18 UNF x 12,7 (0.5) deep	1/2"-13 UNC-2B	50,5 (1.99)	74,2 (2.92)	128,0 (5.04)	151,8 (5.98)	185 (7.28)	103 (4.06)
EDGVM-8Z(-D)-1*-R	G ¹ / ₂ x 22 (0.86) deep (BSPF)	G ¹ / ₄ x12,2 (0.48) deep (BSPF)	M12 x 25 (1.0) deep	50,5 (1.99)	74,2 (2.92)	128,0 (5.04)	151,8 (5.98)	185 (7.28)	103 (4.06)

Model	G	H	J	K	L	M	N	P	Q	R	S	ØT
EDGVM-8(-D)-1*-R	19	21	31	17,4	73	-	35	119	181	92,1	204	10,8
EDGVM-8X(-D)-1*-R	(0.75)	(0.83)	(1.22)	(0.685)	(2.87)	-	(1.38)	(4.69)	(7.13)	(3.63)	(8.03)	(0.425)
EDGVM-8Y(-D)-1*-R	33	17,5	5,6	27	97	72	45	160	202	130	232	13,5
EDGVM-8Y(-D)-1*-S	(1.30)	(0.69)	(0.22)	(1.06)	(3.82)	(2.84)	(1.77)	(6.30)	(7.95)	(5.12)	(9.13)	(0.53)
EDGVM-8Z(-D)-1*-R												

DGSM-8-1*-T** (UNF/SAE ports; UNC mounting bolts)

For up to 210 bar (3000 psi) Maximum Pressure

Ports P, T, A, B, X, Y

Single station subplates

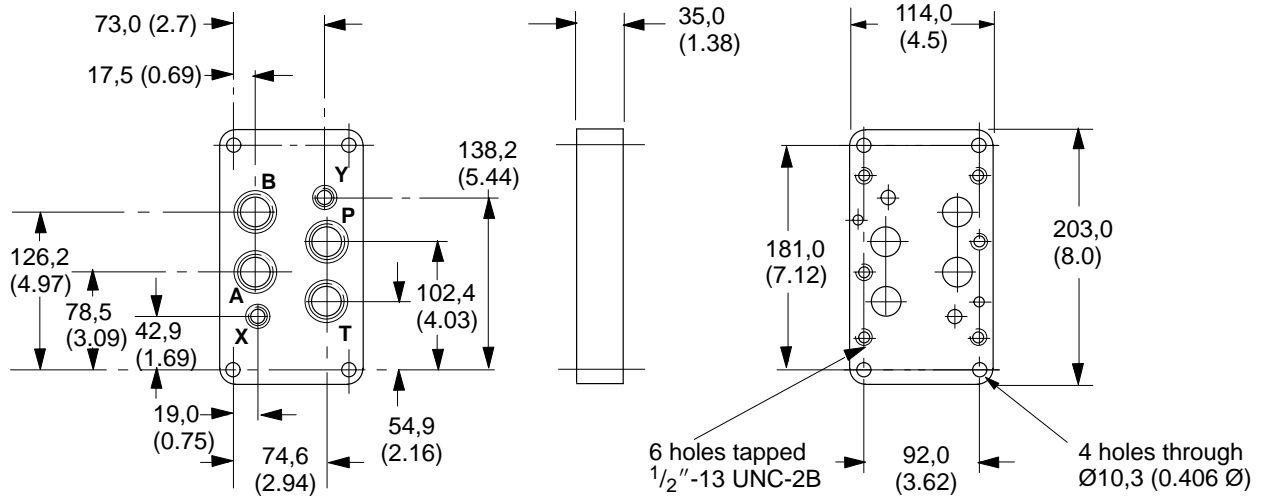
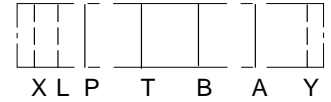

Port Threads

Model	Ports P, T, A, B	Ports X, Y
DGSM-8-1*-T12	1 1/16"-12 UN x 19,1 (0.75) deep	9/16"-18 UNF x 12,7 (0.5) deep
DGSM-8-1*-T16	1 5/16"-12 UN x 19,1 (0.75) deep	9/16"-18 UNF x 12,7 (0.5) deep

Mounting Surface

This interface conforms to:
 ISO 4401-07-06-0-94
 ANSI/B93.7M (and NFPA) size 07
 CETOP R35H4.3-07
 DIN 24340 Form A16

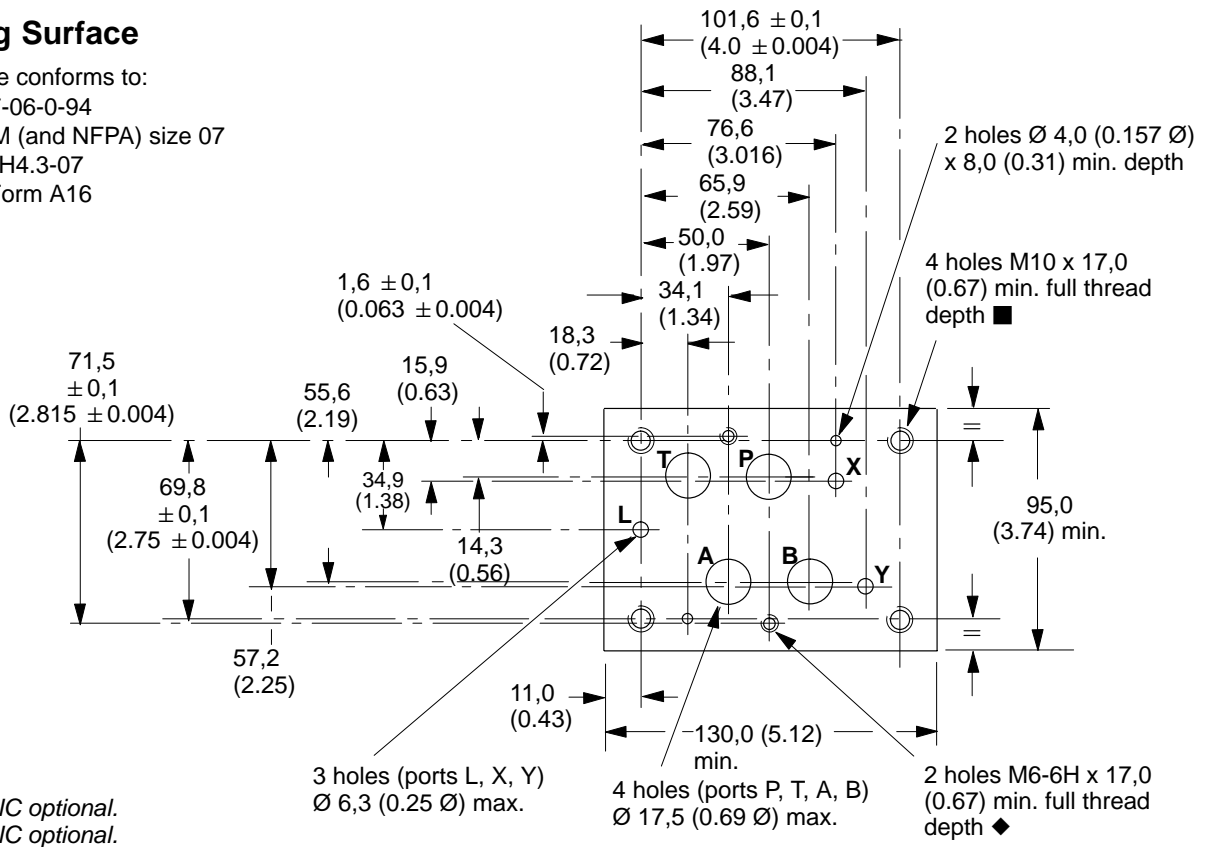

Mounting Surface

This interface conforms to:
 ISO 4401-08-07-0-94
 ANSI/B93.7M (and NFPA) size 08
 CETOP R35H4.3-08
 DIN 24340 Form A25

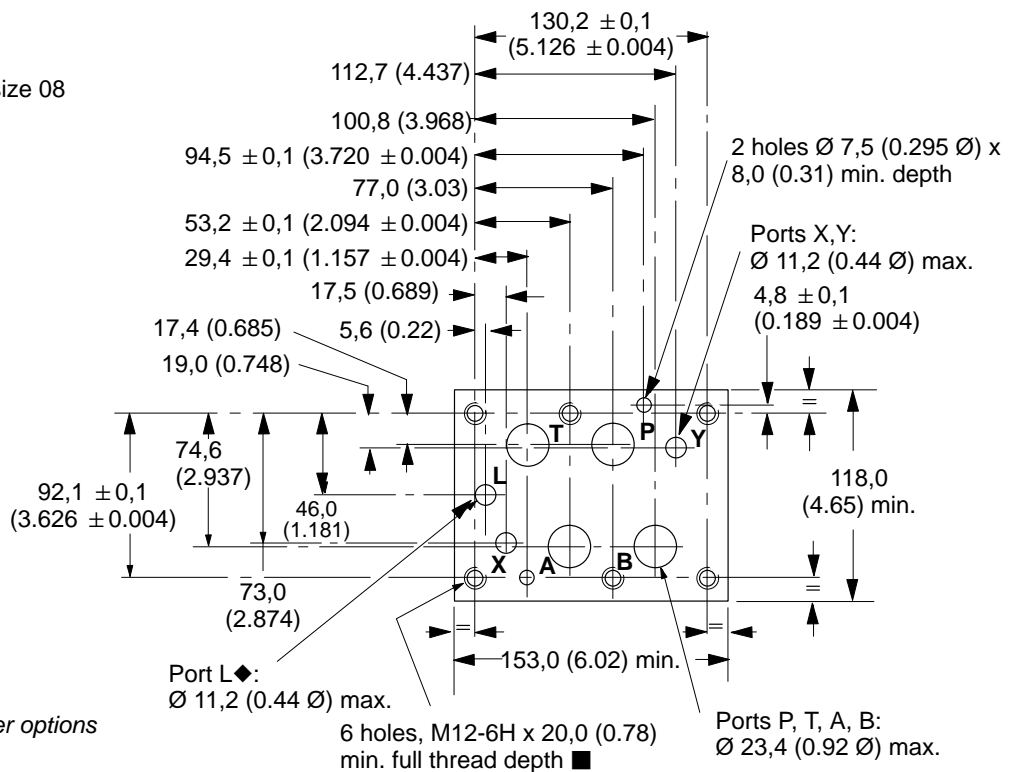

Mounting Surface

Dimensions are show in mm (inches) ▲

A machined pad must be provided for mounting.

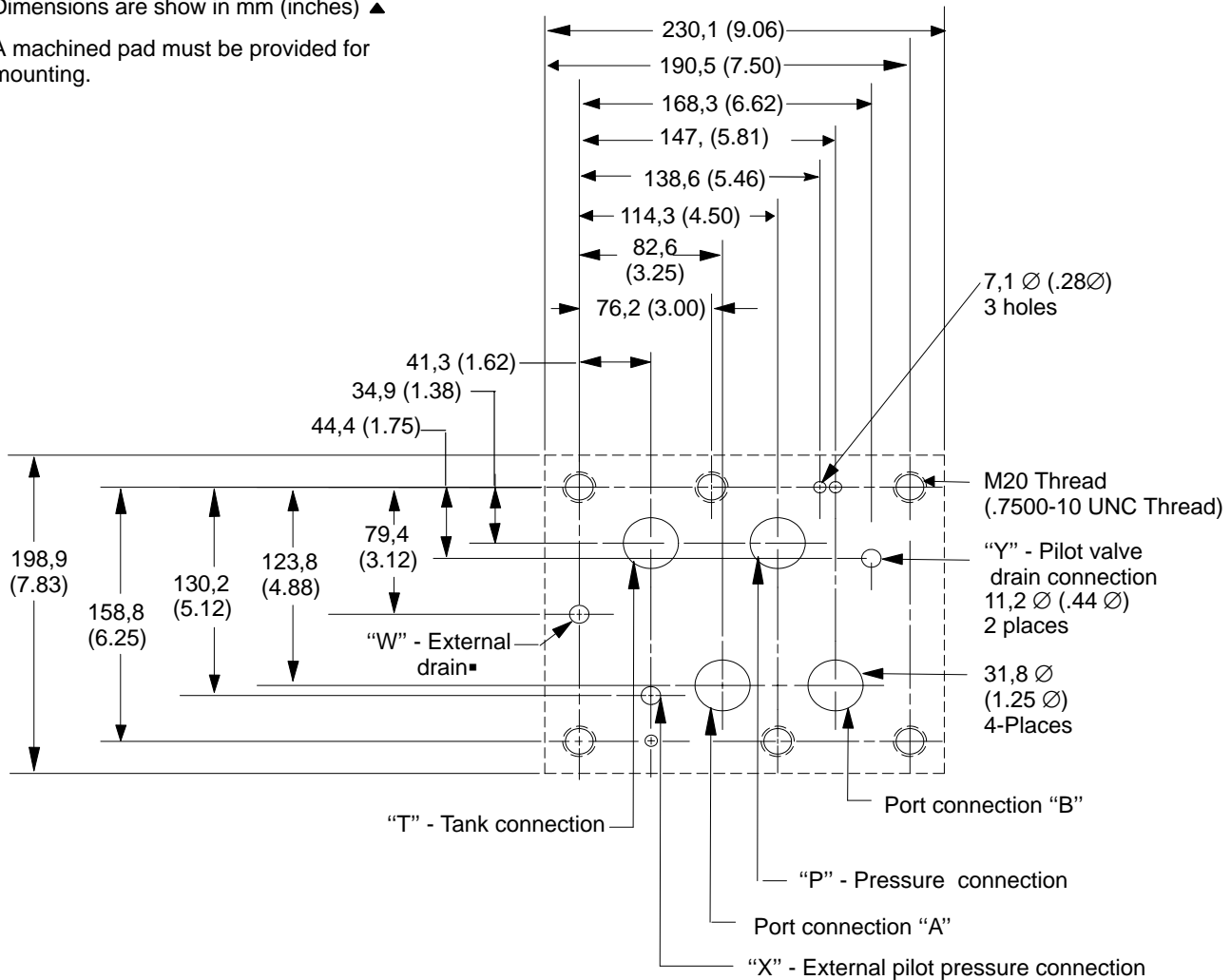

- Required for 'D' Pressure Centered models only

Mounting Bolt Tapping Options

ISO/DIS 4401-02-02 defines only M5 tapping.
Inch tapping options are as available in Vickers subplates and manifolds.

- ▲ ISO 4401 gives dimensions in mm. Inch conversions are accurate to 0.01" unless stated.
- ▼ It is recommended that customers' own manifold blocks for UNC bolts be tapped to these minimum depths.

Thread	Min. tapping depth for subplates/manifolds in:		
	Steel	Cast Iron	Aluminum
Metric	12,3	12,3	12,3
M5-6H	(0.484)	(0.484)	(0.484)
Inch	12,6	14,9	14,9
#10-24 UNC-2B	(0.496)▼	(0.587)▼	(0.587)▼

Electrical Information

Plug connector (Order separately) (ISO4400/DIN 43650)

Cable diameter range . . . Ø6–10 mm (0.24–0.40)
 Wire section range Ø,5–1,5 mm² (0.0008–0.0023 in²)
 Terminals Screw type
 Type of protection IEC144 class IP65, when plugs are fitted correctly to the valves with the interface seals (supplied with plugs) in place.

Connector can be positioned at 90° intervals on valve by re-assembling contact holder into appropriate position inside connector housing. Connectors with and without indicator lights are available (order separately).

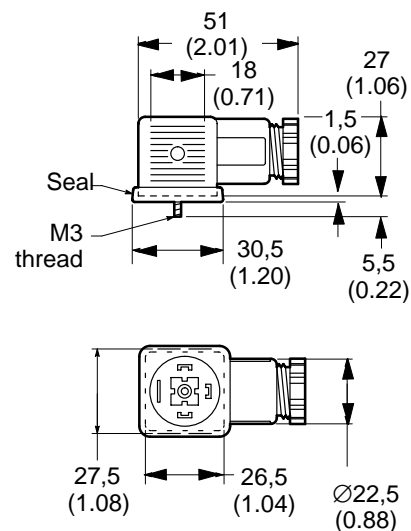
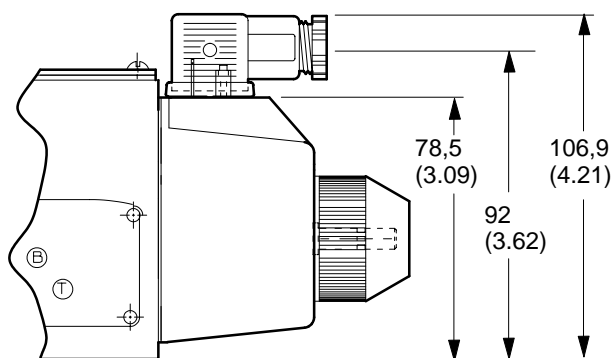

Receptacle	Voltage (AC or DC)	Gray "A" sol.	Black "B" sol.
Without lights	—	710776	710775
With lights	12-24	977467	977466
	100-125	977469	977468
	200-240	977471	977470

Typical Connection Arrangements

KADG5V-5/7/8, valves with integral amplifier

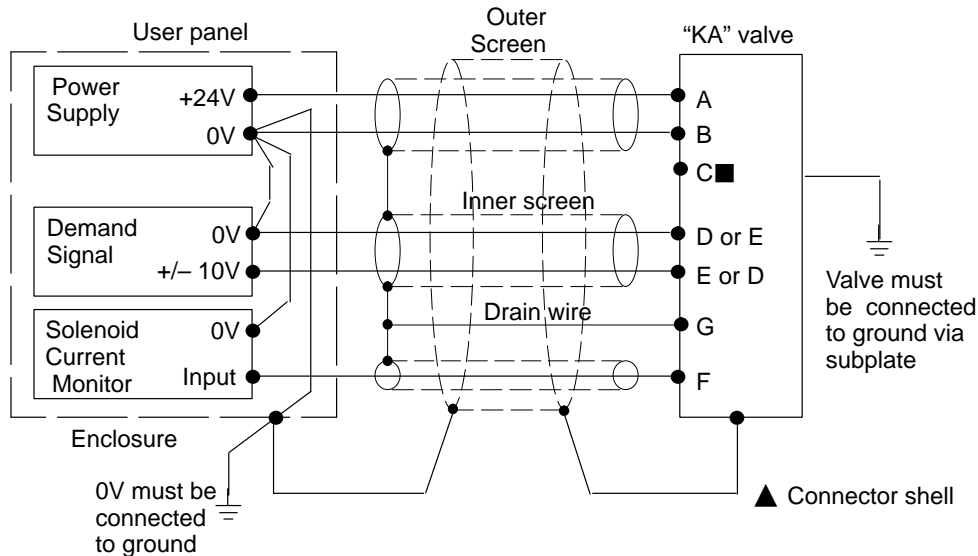

■ Solenoid current monitor voltage (pin F) will be referenced to the KA valve local ground. A "local ground" (pin C) is provided for optional use by differential input customer supplied electronics.

▲ Note: In applications where the valve must conform to European RFI/EMC regulations, the outer screen (shield) must be connected to the outer shell of the 7-pin connector and the valve body must be fastened to the earth ground. Proper earth grounding practices must be observed in this case, as any differences in command source and valve ground potentials will result in a screen (shield) ground loop.



Warning

Do not ground pin C. If the local ground (pin C) is not used for differential monitor electronics, do not use. Read monitor pin F with respect to ground.



Warning

Electromagnetic Compatibility (EMC)

It is necessary to ensure that the valve is wired-up as above. For effective protection, the user electrical cabinet, the valve subplate or manifold, and the cable screens should be connected to efficient ground points. The metal 7-point connector, part no. 934939, should be used for the integral amplifier.

In all cases, both valve and cable should be kept as far as possible from any sources of electromagnetic radiation such as cables carrying heavy current, relays and certain kinds of portable radio transmitters, etc. Difficult environments could mean that extra screening may be necessary to avoid the interference.

It is important to connect the 0V lines as shown above. The multi-core cable should have at least two screens to separate the demand signal and monitor output from the power lines.

Electrical Block Diagram

KADG5V5-5/7/8, valves with integral amplifier

Wiring

Connections must be made via the 7-pin plug mounted on the amplifier.

Recommended cable sizes are:

Power cables:

For 24V supply

0,75 mm² (18 AWG) up to 20m (65 ft)

1,00 mm² (17 AWG) up to 40m (130 ft)

Signal cables:

0,50 mm² (20 AWG)

Screen:

A suitable cable would have 7 cores, a separate screen for the signal wires and an overall screen. See wiring connection diagram on previous page.

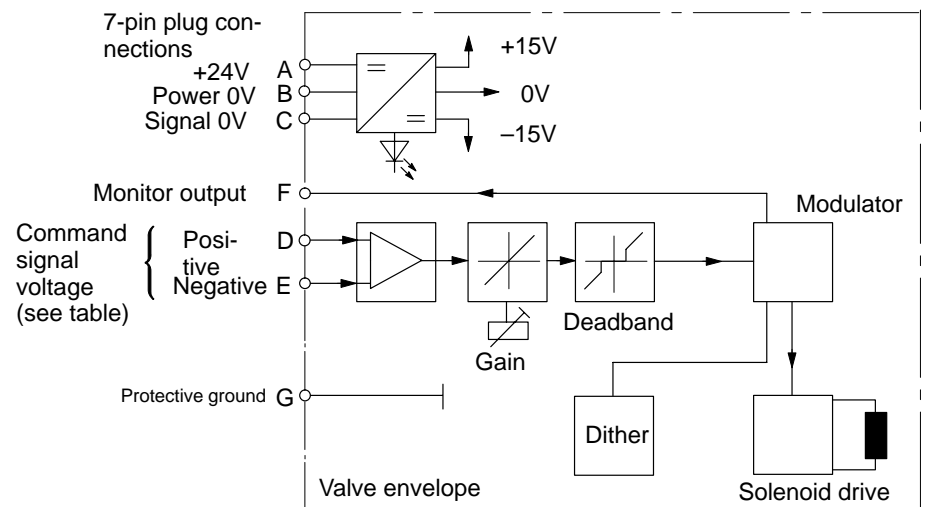

Warning

All power must be switched off before connecting or disconnecting any plugs.

Single-Cable UNIPLUG Connector EHH-AMP-724 D ** - 1*

Vickers UNIPLUG is a single-cable electrical connector ideally suited for economical wiring of single and double-solenoid models. It is introduced on the well-established size 3 proportional valves, KDG4V-3(S), 60 series, respectively. The UNIPLUG connector is released in four 24V versions, offering:

- Control of proportional valves from low voltage differential input signal
- Direct switching of 24V DC solenoids

The UNIPLUG connector is supplied loose for customer assembly to valves, *which must be fitted with type "P" plug-in coils.*

The correctly installed UNIPLUG/ valve combination conforms to protection code IEC 529 class IP67.

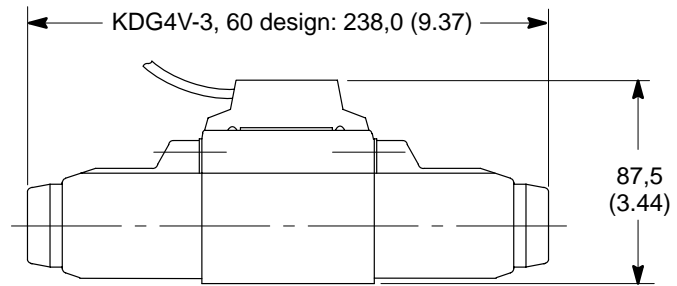

Double solenoid models

Operating Data

Cable: wire size cable sheathing cable screening	1 mm ² (18 AWG) Polyurethane Types C and D only
Ambient temperature range: operating storage	-20 to +70°C (-4 to +158°F) -25 to +70°C (-13 to +158°F)
Electro-magnetic compatibility (EMC) emission immunity	EN50081-2 EN50082-2
Protection class	IEC 529, IP67 when correctly assembled and installed on a designated valve type
Housing material	Ultramid A3 HG3



This product has been designed and tested to meet specific standards outlined in the European Electromagnetic Compatibility Directive (EMC) 89/336/EEC, amended by 91/263/EEC. For instructions on installation requirements to achieve effective protection levels, see this leaflet and the Installation Wiring Practices for Vickers Electronic Products leaflet 2468. Wiring practices relative to this directive are indicated by  European Electromagnetic Compatibility (EMC)

Electrical Data, Type D

Plug with proportional amplifiers with independent adjustable gain and deadband for each of two solenoid outputs, plus a common adjustable ramp.

LEDs show status of output.

Connections (coded to DIN VDE 0293): wire no. 1 wire no. 2 wire no. 3 wire no. 4 screen	Positive command signal Negative command signal 0V (power and signal) 24V power supply Connect to a suitable ground point
Power supply (to VDE 0160) Max. permissible voltage	24V DC (20.4V to 30.4V incl. $\pm 10\%$ ripple) 36V DC <i>for less than 100 ms</i>
Protection	Reverse polarity protected Short circuit protected
Differential command signal max. command-current Input resistance Protected against overvoltage	-10V to +10V. See "Command Signal" table on next page 1 mA 10 k Ω ± 50 volts
Output current per solenoid: rated max.	1.6A 1.8A
Output voltage at 1.6A output current	Typically 1.5V below supply voltage
Max. power consumption with one solenoid energized	35W
Ramp adjustment \blacksquare range	50 ms to 5 sec
Deadband compensation \blacksquare , independent for each solenoid Trigger level for deadband	200 to 700 mA +/- 100 mV
Gain adjustment \blacksquare range, independent for each solenoid	0.04 to 0.14 A/V
PWM frequency	240 Hz (optimum for KD/TG4V-3(S) valves)
Installation and start-up guidelines	GB/D-9144

\blacksquare *Vibration can cause potentiometer setting to change by up to approx. 5%. To avoid this effect, it is recommended to seal the adjusting screws (e.g. Loctite Screwlock 222).*

Electrical Block Diagram

EHH-AMP-724-D**-1*

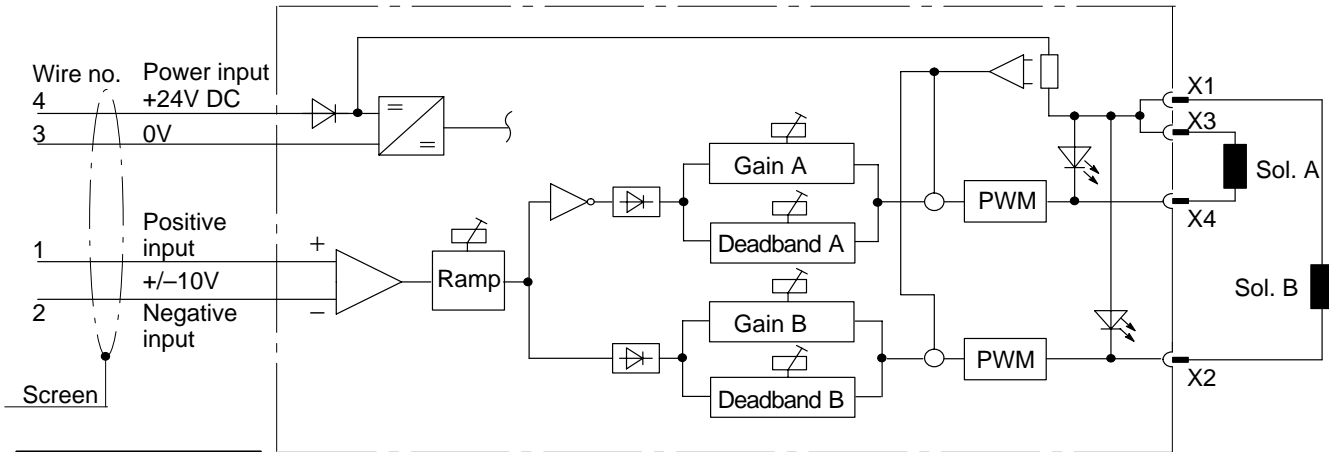

Command Signals

Input	Wire 1	Wire 2	Output
Differential	Positive	Negative	A
	Negative	Positive	B
Non-inverting	Positive	0V	A
	0V	Positive	B
Inverting	0V	Negative	A
	Negative	0V	B

Identification Symbols

EHH-AMP-724-D**-1*

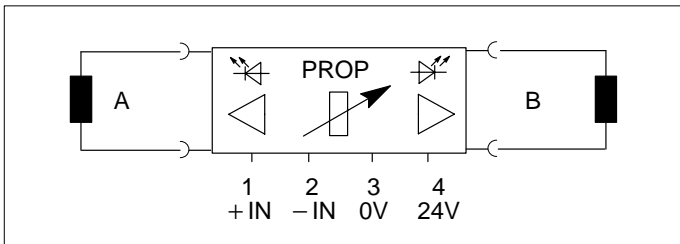

3rd angle projection

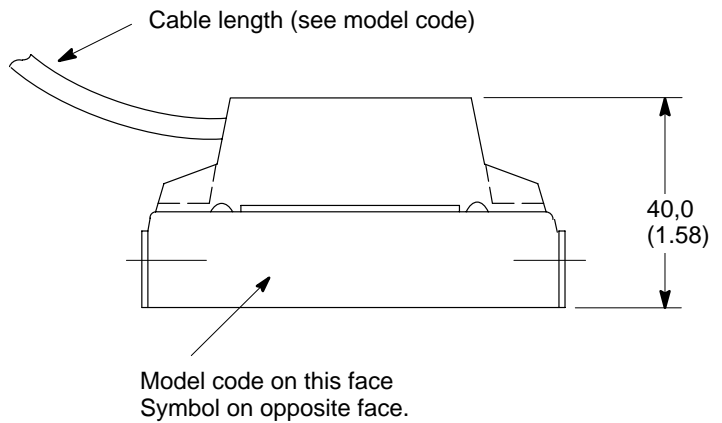
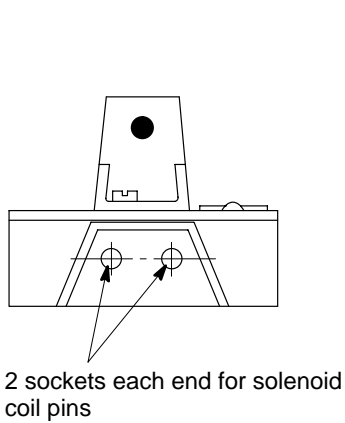
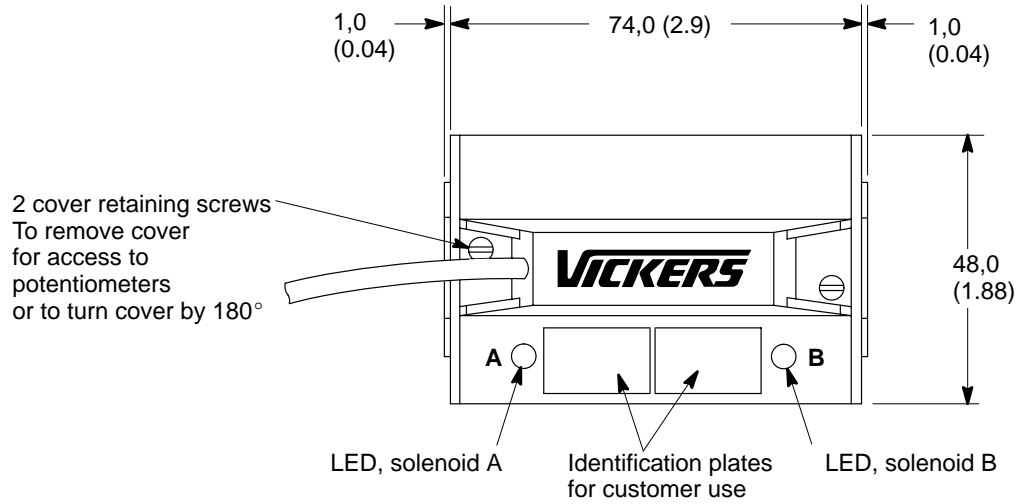
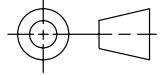

Type D

Shown with cover removed for access to potentiometers

Potentiometer Adjustments

Ramp: Turn clockwise to increase ramp time

Deadband: Turn clockwise to increase deadband compensation

Gain: Turn clockwise to increase gain

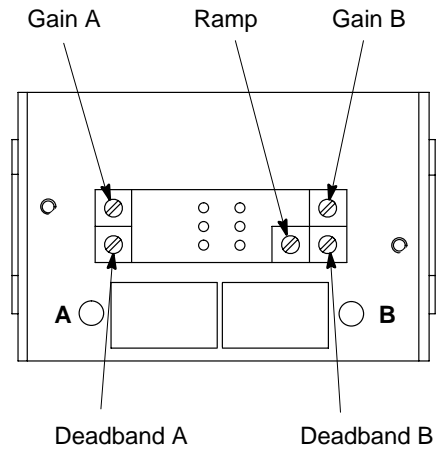

Installation Data

Installation Data

Mounting Interfaces**KDG5V-5** ISO 4401, size 05 with additional pilot ports. Refer to page B.12 for dimensional data.
KDG5V-7 ISO 4401, size 07. Refer to page B.12 for dimensional data.
KDG5V-8 ISO 4401, size 08. Refer to page B.12 for dimensional data.
KDG5V-10 ISO 4401, size 10. Refer to page B.14 for dimensional data.

SubplatesFor KDG5V-5, see page B.17.
For KDG5V-7, see see page B.18.
For KDG5V-8, see see page B.18.

DGAM-5 Pilot Ports Adaptor Module for KDG5V-5 ModelsProvides for external connections to pilot ports if ports X and Y are not present in valve subplate/manifold block. For mounting bolts for valve plus adaptor, see below.

Max. pressure: 210 bar (3000 psi)

Model types:
DGAM-5-1*-R: G $\frac{1}{4}$ " (1/4" BSPF) port tapings
DGAM-5-1*-S: $\frac{9}{16}$ "-18 UNF-2B port tapings

Mounting Bolt Kits

For KDG5V-5
BK02-156493M (metric)
BK590720 (inch)
For KDG5V-7
BKDG7M (metric)
BK590724 (inch)

For KDG5V-8
BKDGH8658M (metric)
BKDGH06618 (inch)

For KDG5V-8
BK98613M (metric)
BK306 (inch)

For KDG5V-10
BKDG10636M (metric)
BKDG10636 (inch)
If not using Vickers recommended bolt kits, bolts used should be to ISO 898, 12.9 or better.

Mounting Bolt Torques

Recommended torques with threads lubricated
For KDG5V-5
M6 or $\frac{1}{4}$ "-20 UNC bolts:
To 210 bar (3000 psi) 14 Nm (10.3 lbf ft)
To 315 bar (4500 psi) 20 Nm (14.75 lbf ft)

For KDG5V-7
M10 or $\frac{3}{8}$ "-16 UNC bolts:
49 to 59 Nm (36 to 43 lbf ft)
plus
M6 or $\frac{1}{4}$ "-20 UNC bolts
9 to 14 Nm (6.6 to 10.3 lbf ft)

For KDG5V-8
M12 or $\frac{1}{2}$ "-13 UNC bolts
103 to 127 Nm (76 to 93 lbf ft)

For KDG5V-10
M20 or $\frac{3}{4}$ "-10 UNC-2B bolts
185-220 Nm (250-300 lbf ft)

Mass (Weight)

Approx. for models with integral pilot pressure reducing module ("X" or "EX"see mode code).
KDG5V-5 9,5 kg (21 lb)
KDG5V-7 11,5 kg (25.3 lb)
KDG5V-8 20,2 kg (44.5 lb)
KDG5V10 54,5 kg (120.0 lb)
For models without integral pressure reducing module (No symbol, or "E", see model code), deduct 1,2 kg (2.6 lb).

Application Data

Fluid Cleanliness

Proper fluid condition is essential for long and satisfactory life of hydraulic components and systems. Hydraulic fluid must have the correct balance of cleanliness, materials and additives for protection against wear of components, elevated viscosity and inclusion of air.

Essential information on the correct methods for treating hydraulic fluid is included in Vickers publication 561, "Vickers Guide to Systemic Contamination Control," available from your local Vickers distributor or by

contacting Vickers, Incorporated. Recommendations on filtration and the selection of products to control fluid condition are included in 561.

Recommended cleanliness levels, using petroleum oil under common conditions, are based on the highest fluid pressure levels in the system and are coded in the chart below. Fluids other than petroleum, severe service cycles or temperature extremes are cause for adjustment of these cleanliness codes. See Vickers publication 561 for exact details.

Vickers products, as any components, will operate with apparent satisfaction in fluids with higher cleanliness codes than those described. Other manufacturers will often recommend levels above those specified.

Experience has shown, however, that life of any hydraulic components is shortened in fluids with higher cleanliness codes than those listed below. These codes have been proven to provide a long trouble-free service life for the products shown, regardless of the manufacturer.

Product	System Pressure Level		
	<70 (<1000)	70-210 (1000-3000)	210+ (3000+)
Vane Pumps – Fixed	20/18/15	19/17/14	18/16/13
Vane Pumps – Variable	18/16/14	17/15/13	
Piston Pumps – Fixed	19/17/15	18/16/14	17/15/13
Piston Pumps – Variable	18/16/14	17/15/13	16/14/12
Directional Valves	20/18/15	20/18/15	19/17/14
Pressure/Flow Control Valves	19/17/14	19/17/14	19/17/14
CMX Valves	18/16/14	18/16/14	17/15/13
Servo Valves	16/14/11	16/14/11	15/13/10
Proportional Valves	17/15/12	17/15/12	15/13/11
Cylinders	20/18/15	20/18/15	20/18/15
Vane Motors	20/18/15	19/17/14	18/16/13
Axial Piston Motors	19/17/14	18/16/13	17/15/12
Radial Piston Motors	20/18/14	19/17/13	18/16/13

Hydraulic Fluids

Materials and seals used in these valves are compatible with antiwear hydraulic oils, and non-alkyl-based phosphate esters. The extreme operating viscosity range is 500 to 13 cSt (2270 to 70 SUS) but the recommended running range is 54 to 13 cSt (245 to 70 SUS).

Fluid Temperatures

For mineral oil:

Min. -20°C (-4°F)

Max. * +70°C (+158°F)

* To obtain optimum service life from both fluid and hydraulic system, 65°C (150°F) normally is the maximum temperature.

Whatever the actual temperature range, ensure that viscosities stay within viscosities specified in the "Hydraulic Fluids" section.

Алматы (7273)495-231
 Ангарск (3955)60-70-56
 Архангельск (8182)63-90-72
 Астрахань (8512)99-46-04
 Барнаул (3852)73-04-60
 Белгород (4722)40-23-64
 Благовещенск (4162)22-76-07
 Брянск (4832)59-03-52
 Владивосток (423)249-28-31
 Владикавказ (8672)28-90-48
 Владимир (4922)49-43-18
 Волгоград (844)278-03-48
 Вологда (8172)26-41-59
 Воронеж (473)204-51-73
 Екатеринбург (343)384-55-89

Иваново (4932)77-34-06
 Ижевск (3412)26-03-58
 Иркутск (395)279-98-46
 Казань (843)206-01-48
 Калининград (4012)72-03-81
 Калуга (4842)92-23-67
 Кемерово (3842)65-04-62
 Киров (8332)68-02-04
 Коломна (4966)23-41-49
 Кострома (4942)77-07-48
 Краснодар (861)203-40-90
 Красноярск (391)204-63-61
 Курск (4712)77-13-04
 Курган (3522)50-90-47
 Липецк (4742)52-20-81

Магнитогорск (3519)55-03-13
 Москва (495)268-04-70
 Мурманск (8152)59-64-93
 Набережные Челны (8552)20-53-41
 Нижний Новгород (831)429-08-12
 Новокузнецк (3843)20-46-81
 Ноябрьск (3496)41-32-12
 Новосибирск (383)227-86-73
 Омск (3812)21-46-40
 Орел (4862)44-53-42
 Оренбург (3532)37-68-04
 Пенза (8412)22-31-16
 Петрозаводск (8142)55-98-37
 Псков (8112)59-10-37
 Пермь (342)205-81-47

Ростов-на-Дону (863)308-18-15
 Рязань (4912)46-61-64
 Самара (846)206-03-16
 Санкт-Петербург (812)309-46-40
 Саратов (845)249-38-78
 Севастополь (8692)22-31-93
 Симферополь (3652)67-13-56
 Смоленск (4812)29-41-54
 Сочи (862)225-72-31
 Ставрополь (8652)20-65-13
 Сургут (3462)77-98-35
 Сыктывкар (8212)25-95-17
 Тамбов (4752)50-40-97
 Тверь (4822)63-31-35

Тольятти (8482)63-91-07
 Томск (3822)98-41-53
 Тула (4872)33-79-87
 Тюмень (3452)66-21-18
 Ульяновск (8422)24-23-59
 Улан-Удэ (3012)59-97-51
 Уфа (347)229-48-12
 Хабаровск (4212)92-98-04
 Чебоксары (8352)28-53-07
 Челябинск (351)202-03-61
 Череповец (8202)49-02-64
 Чита (3022)38-34-83
 Якутск (4112)23-90-97
 Ярославль (4852)69-52-93

Россия +7(495)268-04-70

Казахстан +7(7172)727-132

Киргизия +996(312)96-26-47